

# National Children's Science Congress

2014-2015

## ACTIVITY GUIDE

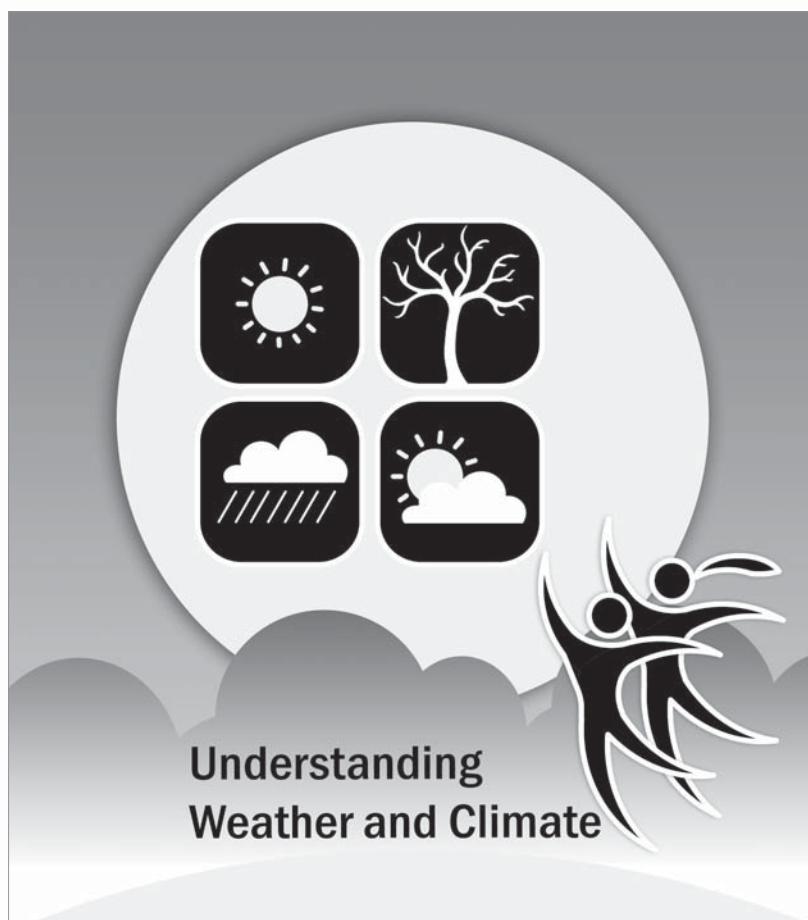

Published by **PSF**



**Pondicherry Science Forum,**

No.10, 2<sup>nd</sup> St, PR Gardens,  
Reddiarpalayam Pondicherry-605010

Catalysed and Supported by **NCSTC**



**National Council for Science & Technology  
Communication (NCSTC)**

Department of Science & Technology, Govt. of India.

*This resource material compiled in this publication was developed during the Brainstorming Workshop held at Pondicherry, during May 1 - 4, 2014. Many suggestions given at the National Orientation Workshop held at Sri Ramachandra University, Chennai during July 3-5, 2014 have also been incorporated.*

**Core Working Group for Activity Guide Book development.**

*Advisors.*

**Dr.B. P. Singh**, Head & Advisor, NCSTC, DST, Govt. of India.

**Dr.D. K. Pandey**, Scientist, F, NCSTC, DST. Govt. of India.

*Working Group.*

**Mr.T.P.Raghunath** (Coordinator) **Mr.Jayanta Kumar Sarma**

**Dr.Pulin Behari Chakraborty** **Prof.E.Kunhikrishnan**

**Dr.Lalit Sharma** **Er.U.N.Ravikumar**

**Dr.P.Pramod**

*Designed and Illustrated by*

**Basheer Ahmed M**, Finline, Chennai - 600 014.

*Published by*

**Pondicherry Science Forum**

No.10, 2<sup>nd</sup> Street, PR Gardens,

Reddiarpalayam, Puducherry-605010.

Web: [www.psferd.org](http://www.psferd.org)

Email: [cerdpsf@gmail.com](mailto:cerdpsf@gmail.com); Phone: 0413-2290733.

*Catalyzed & Supported by*

**National Council for Science & Technology Communication (NCSTC)**

**Department of Science & Technology**

**Technology Bhavan, New Mehrauli Road,**

**NEW DELHI-110 016.**

**Email: [dkp@nic.in](mailto:dkp@nic.in)**

**Telephone: 011-26535564/ 226590251.**



सत्यमेव जयते



भारत सरकार  
विज्ञान और प्रौद्योगिकी मंत्रालय,  
विज्ञान और प्रौद्योगिकी विभाग,  
टेक्नोलॉजी भवन, महरौली मार्ग,  
नई दिल्ली-110016

GOVERNMENT OF INDIA  
MINISTRY OF SCIENCE AND TECHNOLOGY,  
DEPARTMENT OF SCIENCE AND TECHNOLOGY,  
TECHNOLOGY BHAVAN, NEW MEHRAULI ROAD,  
NEW DELHI-110016

### FOREWORD

Science is intrinsic to human being and so is technology. Everyone is born with power of logic and argument. Scientific temper is as integral part of human persona as is temper itself- good or bad. Whatever one does, he applies the power of logic to reach at conclusions. The life experiences, processes of bringing one up, prevailing beliefs and practices in the society become foundation stone of one's persona.

India is an ancient country and a melting pot of cultures since time immemorial. In the process of transition from one period to another, society has imbibed myriad's of beliefs and practices which are not in sync with modern scientific knowledge. Its journey from ancient prehistoric to Hindu to Muslim to Mughal to British and Modern constitutional republic has been a long journey. The social amalgamation of all kinds of ethnicity has brought out a composite culture which has learned from each other a lot – good and bad.

Our forefathers decided to make Science and Technology (S&T) a driving force for development and transformation of the society to be able to use the fruits of S&T. A bare minimum of scientific knowledge is necessary to use it but equally important is awareness of the processes of science – the method through which scientific knowledge is generated.

National council for Science and Technology Communication (NCSTC) strives to popularise S&T among masses. It uses many methods to achieve it- Jathas, exhibitions and demonstrations- static as well mobile, community radios, training of resource persons particularly teachers, field projects etc. Students are very pro-learning segment of society and are every effective in bringing transformation, NCSTC, therefore engages with them through National Children Science Congress (NCSC).

The NCSC has a centrally decided scientific theme, socially relevant and modern- and expects children in the age group of 10-17 years to form a small group under a guide teacher in his school, select a sub-theme from the main theme, develop a hypothesis, design experiments, collect data, organise and analyse it before reaching on conclusion. We expect students to develop traits of working in a team, be able to appreciate that science is for society and acquire knowledge of method of science.

The focal theme this year is "Understanding Weather and Climate", the very important and socially relevant current research issue world over. The guide book on this broad theme is ready to go to press. It will be distributed widely among the organising and technical coordinators and guide teachers. Competition and recognition of merit is introduced at district, state and national level. National level congress is due on DEC 27-31, 2014 at Bangalore. The successful projects entitle students for attending Indian National Science Congress, visit of front ranking research laboratory and participation in International Fair of Science and Engineering (ISEF), USA in May 2015. Looking forward to see you at Bangalore. My best wishes to all of you.

With best wishes,

(Dr. Bhanu Pratap Singh)  
Scientist 'G' & Head (NCSTC)

New Delhi  
Dated : 11.08.2014



NCSTC-NETWORK

## NCSTC – Network

Communicating Science in India

Address: E – 56, 1<sup>st</sup> floor, Samaspur Road, Panday Nagar, Delhi – 110 091  
 Regd. Office: Technology Bhawan, New Mehrauli Road, New Delhi – 110 016

Ph.: +91 – 11 – 22799236, E-mail: ncstcnet@hotmail.com, Website: www.ncstc-network.org

**President**  
**Padma Vibhushan**  
**Prof. Yash Pal**  
 Ex-Chairman – UGC  
 Ex-Chancellor - JNU

**Chairman**  
**Er. Anuj Sinha**  
 Ex-Head & Advisor, NCSTC, DST, Govt. of India  
 Ex-Director, Vigyan Prasara, DST, Govt. of India

**General Secretary**  
**Prof. Khwaja M Rafi**  
 Principal – Brown Hills College  
 of Engineering & Technology,  
 Faridabad

### MESSAGE



Children's Science Congress is a celebration of practical science. It is an inclusive platform where young scientists use their scientific skills to address real problems. The challenge begins from selecting the issue, analysing and examining it, suggesting solutions, working on a likely path. You develop science communication skills also as you are required to present the work and results before peers and experts.

An important skill that you improve is statistical methods and pattern recognition. This is to be attempted in as rigorous way as possible with significant sample size and accurate data collection. Both these facets will be useful in your adult career – as a scientist or any other professional.

Important aspects of 'Climate Change and Weather' are explored in the guidebook and you must spend time not only on the text but also the helpful references. Many experts have worked selflessly and contributed magnanimously to this volume. Studying this will make you more sensitive to a lot of issues that are the subject matter of international debate and negotiation.

Mitigation and adaptation are terms that have been kept in the margins in this guide book. These are very important and require discussion on very complex and contentious issues. I expect eminent experts to dwell on this at the State and National Congress.

Scientists of the Network along with other eminent experts make the whole process exciting and enriching for the young researchers, mentors, evaluators and organisers. Your feedback and experience is very important. Each edition of the Congress results in many interesting learnings for us. I would like to make the next event even more rich and relevant for the next generation of researchers.

I extend my greetings and good wishes to the delegates at the District, State and National Congress!

(Er. ANUJ SINHA)

**A Note from National Programme Coordinator  
Dr.D.K.Pandey  
Scientist F, NCSTC & National Programme Coordinator.**



भारत सरकार  
विज्ञान और प्रौद्योगिकी मंत्रालय  
विज्ञान और प्रौद्योगिकी विभाग,  
टेक्नोलॉजी भवन, महरौली मार्ग  
नई दिल्ली-110016



GOVERNMENT OF INDIA  
MINISTRY OF SCIENCE AND TECHNOLOGY,  
DEPARTMENT OF SCIENCE AND TECHNOLOGY,  
TECHNOLOGY BHAVAN, NEW MEHRAULI ROAD,  
NEW DELHI-110016

D.O. No.

Dated .....

**From the desk of National Programme Coordinator**

The Children's Science Congress (CSC) which was initiated in 1993 has reached to 22 years with its glorious existence. If we look back the initial year of CSC i.e. 1993 magnitude wise only 19 states not even all districts within the states were able to participate in national event, the present day scenario is completely changed, now at present, all the states with more than 600 odd districts are associated in organizing the CSC at district level. Some of the states has stepped ahead and gone down into the block level in order to have more coverage of schools. The schools of Kendriya Vidhyalaya Sangathan and Navodaya Vidhyalaya Samiti have given the status of separate statehood. ASEAN countries are regularly sending their child scientists to participate in the national event of NCSC. United Arab Emirates has started sending their child scientists delegation in the national event of NCSC. Neighbouring countries are also trying to send their participants in national event of NCSC.

The two decades journey of CSC is reflecting the wide range of critical and innovative ideas of the children through their innovative project work on a variety of highly relevant local issues from different parts of the country. It is widely acknowledge the process of this programme which relate the day-to-day issues of day-to-day life under one of the sub theme of focal theme by employing the 'method of science' observation, measurement, validation and analyses to reach into feasible solution of the problem.

India's weather and climate conditions are control by her geographical location (i.e. its latitudinal and longitudinal extents). Himalayan ranges right from north western to north eastern corner in the northern side, existence of Indian Ocean and Arabian sea as well as Bay of Bengal in south west to south east. The country also encompass the western ghats, extending along with the west coast of India from vindhya satpura ranges in the north to the southern tip of the peninsula with a stretch of 1600 kms., receiving an average of nearly 6000mm of rainfall every year. Weather and Climate are among the key factors that determine the nature, condition and pattern of natural resources. State of temperate, humidity and precipitation in temporal context in a year determine season and climatic condition in long temporal context.

The Activity Guide (Weather & Climate as a Focal theme for the year 2014 & 15) is brought out with the great efforts of the Experts and Resource Persons involved in the brainstorming session and further involvement of State Academic Coordinator and State Resource Person who had participated in the National Orientation Workshop gave a great help in finalizing the Activity Guide Book. The members of Core Committee have taken an extra responsibility to carryout all the exercises in designing and developing the content of Activity Guide. It would not have been possible without active cooperation and support of the Pondicherry Science Forum, Pondicherry and Sri Ramachandra Medical University, Chennai to carryout the necessary exercises needed in the process. We really grateful to all the individual organizations associated in their own way in designing and developing the Activity Guide Book.

We hope that the Activity Guide Book will help the State and District Coordinators, Resource Persons, Teachers guide and Evaluators to carryout the activity, resulting the valuable and potential project ideas that come up in different level of CSC will prove to be useful in long way to the society at large. Any suggestion with regard to improvement in the Activity Guide is always welcome.

With Best Wishes,

New Delhi  
Dated : 11.08.2014

  
(Dr. D.K. Pandey)  
Scientist 'F'/Director &  
National Programme Coordinator

## **Acknowledgement**

This Activity guidebook for Children’s Science Congress for the years 2014 and 2015 has been made possible because of two major workshops – the National Brainstorming Workshop held at Lycee Francais, Pondicherry (1-4 May 2014) and the National Orientation Workshop held at Sree Ramachandra Medical Centre, Porur, Chennai (3-5 July 2014). Our thanks are due to the entire team of experts, participants, members of the National Academic Committee, each of the Coordinating Agencies of the States, UTs, the Kendriya Vigyalaya Sanggathan, the Jawahar Navodaya Vidyalaya Samithi who took care to send their State Academic coordinators as well as subject experts to the workshop. We also thank the institutions which hosted these two workshops for their unlimited support for making these workshops a success. This activity guidebook is the result of the inputs of all those who have participated in the workshops as well as those State Coordinators who through email have given their valuable suggestions and inputs.

We express our special thanks and gratitude to the Lycee Francais, Pondicherry for their kind hosting of the National Brainstorming Workshop in Pondicherry. We also express our thanks to Dr.Deviprasad, Pondicherry University who helped us in the organization of the National Brainstorming Workshop and also for his valuable inputs.

We have special gratitude and we hereby express our thanks to the Vice Chancellor Prof.JSN Murthy, Sri Ramachandra University, Porur, Chennai and to Prof. S.Thanikachalam, Head, Cardiac Centre, Sri Ramachandra University along with Er.C.E.Karuanakran who made the National Orientation Workshop a big success for their continued and smooth coordinating roles. Their efforts made the workshop a sweet and memorable one for all the participants.

Our special thanks are to Dr.B.P.Singh, Scientist G & Head, NCSTC, DST and Dr.D.K.Pandey, Scientist F, NCSTC, DST and National Programme Coordinator CSC for their unfailing encouragement, support, guidance and valuable inputs for making this effort fruitful and a reality. We also extend our special thanks to the entire NCSC family & DST for their catalytic support and also for their patience since this whole project was conceived, carried out and accomplished within a very short time of only 5 months. Lastly but not the least, we extend our thanks and gratitude to the entire team of Pondicherry Science Forum without whose support this would not have been made possible.

On Behalf of the National Academic Core Group.

**Coordinator, NAC.**

## **National Council for Science & Technology Communication (NCSTC) Department of Science and Technology (DST), Government of India**

NCSTC is an apex Organisation of the Department of Science and Technology of Government of India that endeavours to

- Communicate Science and Technology
- Stimulate Scientific and Technological temper
- Coordinate and orchestrate such efforts

### **Goals:**

- to create excitement concerning advances in Science & Technology
- to enable informed decision-making at the grass roots level
- to encourage intelligent debate on developmental issues Important Activities
- Research in thrust areas of science and technology communication;
- Development of scripts, films, video and radio programmes, books, slide sets, etc., on selected areas of science and technology;
- Training (short term) for school teachers and activists of science & technology based voluntary organisations in science communication;
- Development of science journalists through University Courses in Science and Technology Communication;
- Awards and recognition for outstanding science communicators;
- Coordination with state councils and networks of S& T based organisations;
- Developing capacity through science communication
- Field programmes for demonstrating innovative ideas of science popularisation, outreach and extension activities including National Children's Science Congress, Science Day celebrations, promotion of voluntary blood donation programmes, environmental awareness and positive action, etc., and Promoting International Cooperation for mutual benefit.

### **For further details please contact**

National Council for Science & Technology Communication  
Department of Science and Technology  
Technology Bhavan, New Mehrauli Marg,  
New Delhi 110016  
Phones: 011-26521865/011-26590302  
Fax: 011-26521865  
Visit: [http://www.dst.gov.in/scientific-programme/s-t\\_ncstc.htm](http://www.dst.gov.in/scientific-programme/s-t_ncstc.htm)

### **About Pondicherry Science Forum**

**Pondicherry Science Forum (PSF)** was formed in the year 1985 with the core objective of Science Communication among the public. Over the years, PSF has established its name in the fields of Science education, literacy and continuing education, women's empowerment, S&T based action research in the areas of Natural resource management, energy, participation irrigation management, non-chemical organic farming, health and sanitation etc. PSF, has, over the years have carried out extensive work in the above areas and have wide experience too. PSF won the National NCSTC Award for the best science communication efforts in the year 1994.

PSF has been a very active partner with the NCSTC, DST since its inception and it also initiated the first Tamil Science monthly, Thulir which it jointly publishes with Tamilnadu Science Forum. PSF is the State Coordinating agency for NCSC since the very first year 1993 for the UT of Pondicherry.

Apart from NCSTC, DST, PSF collaborates with the SEED Division of DST, the State Council for Science & Technology and also a number of technical institutions like the Centre for Sustainable Technologies, Indian Institute of Science, Bangalore.

### **About NCSTC Network.**

The Network was formed about 25 years back with the objectives of initiating and implementing coordinated programmes of science outreach in association with government and non-government organisations. National Council of Science and Technology Communication, Department of Science and Technology, New Delhi catalysed the formation of this organisation.

It is a registered body guided by a Board of Governors with headquarters at Delhi. It has about eighty members spread in all states and union territories. Volunteers in districts lend it great strength and capability for implementing projects that reach the common man and woman.

It has shaped and reshaped the Children's Science Congress every year for the past 21 years giving it more features to make it enriching for all participants. It has organised the Teachers' Science Congress over the past fourteen years giving a platform for innovative science and maths teachers.

Network provides platform for interacting with eminent scientists and encourages young budding scientists also.

The Network led the nation in observing the Year of Scientific Awareness in 2004 and International Year of Physics (Appreciating Physics in Everyday Life) 2005. It undertook a three year campaign for Planet Earth 2007 and is drawing up ambitious plans for the future.

It has many publications in Hindi, English and regional languages that are always in demand.

The Network welcomes new members to improve the planning and implementation of its programmes. It seeks new areas in development communication, technology outreach and promotion of innovation over the next few years.

Even as rapid developments impact on society, the next phase promises to be even more exciting and rewarding.



## **Contents**

<b><i>Part 1:</i></b>	
About Children’s Science Congress	<b>11</b>
<b><i>Part 2:</i></b>	
Focal Theme: Understanding Weather and Climate	<b>29</b>
Sub Theme 1: Understanding Weather around you	<b>37</b>
Sub Theme 2: Impact of Human Activities on Weather, Climate	<b>49</b>
Sub Theme 3: Weather, Climate & Eco Systems	<b>63</b>
Sub Theme 4: Weather, Climate, Society & Culture	<b>73</b>
Sub Theme 5: Weather, Climate & Agriculture	<b>93</b>
Sub Theme 6: Weather, Climate & Health	<b>115</b>
Additional Project Ideas	<b>132</b>
<b><i>Appendix</i></b>	<b>138</b>
<b><i>Annexures</i></b>	
Annexure I – State wise Quota for National Level CSC	<b>142</b>
Annexure II: State Coordinators	<b>143</b>
Annexure III: Participants of the National Brainstorming workshop	<b>145</b>
Annexure IV: Participants of the National Orientation Workshop	<b>147</b>
Annexure V: Registration Form A	<b>152</b>
Annexure VI: Format for Abstract	<b>153</b>
Annexure VII: : Format for Post Mentoring Score Card	<b>154</b>



*Part 1*  
ABOUT NCSC





# About Children's Science Congress (CSC)

## 1. CSC- The Beginning

The seeds of the programme of children's science congress (CSC), in the way of an exercise to carry out small research activities at micro-level were planned in Madhya Pradesh by an NGO called Gwalior Science Center. It was later adopted by National Council for Science and Technology Communication (NCSTC), Department of Science & Technology (DST), Government of India for carrying out national level activities through NCSTC-Network (a network of Non-Government and Government organizations working in the field of science popularization) as national organizer. It was a time when many of the country's crusaders of science communication were experienced with massive science communication exercise of Bharat Jana BigyanJatha and Bharat Jana GyanBigyanJatha. It was felt that the large scale activities for developing science awareness among the masses are to be continued as regular activity, so, this programme was launched nationwide in 1993, under nomenclature National Children's Science Congress (NCSC), with an expectation that it would generate scientific temperament among the teachers and students, and spread among the various stakeholders of the society. The programme of NCSC has been fruitfully conducted for the last 21 years.

## 2. CSC: An overview

Children's Science Congress is targeted to spread the concept of the method of science among the children their project activities adopting the principle of learning through doing'. The mandate of participation is that, the children will carry out a project on a particular topic in

relation to theme and sub-theme decided for the year. The study is to be carried out in the neighbourhood of the children where they live. For this, the students form a group with their like-minded friends/classmates and the study is carried out under the supervision of a guide. It is noteworthy that, CSC programme is not only for the school going children but is also open for the children outside the formal boundary of schools, in the age group of 10 to 17 years (where 10 to 14 years is considered as junior group and 14 + to 17 years as senior group). Further, it is not mandatory that a guide must be a school teacher; any persons with fair knowledge of dealing with children and method of science are considered eligible to guide the children, but should not be direct relative of any of the children.

The exercise of project activities, as thumb rule, encourages the children to explore, think, serve and wonder. It is capable to imbibe the following temperament/quality/skill of the children:

- Observation
- Making measurement,
- Making comparison and contrasts,
- Classification,
- Estimation,
- Prediction,
- Interpretation,
- Critical thinking,
- Creative thinking,
- Drawing conclusion and
- Cooperative skill

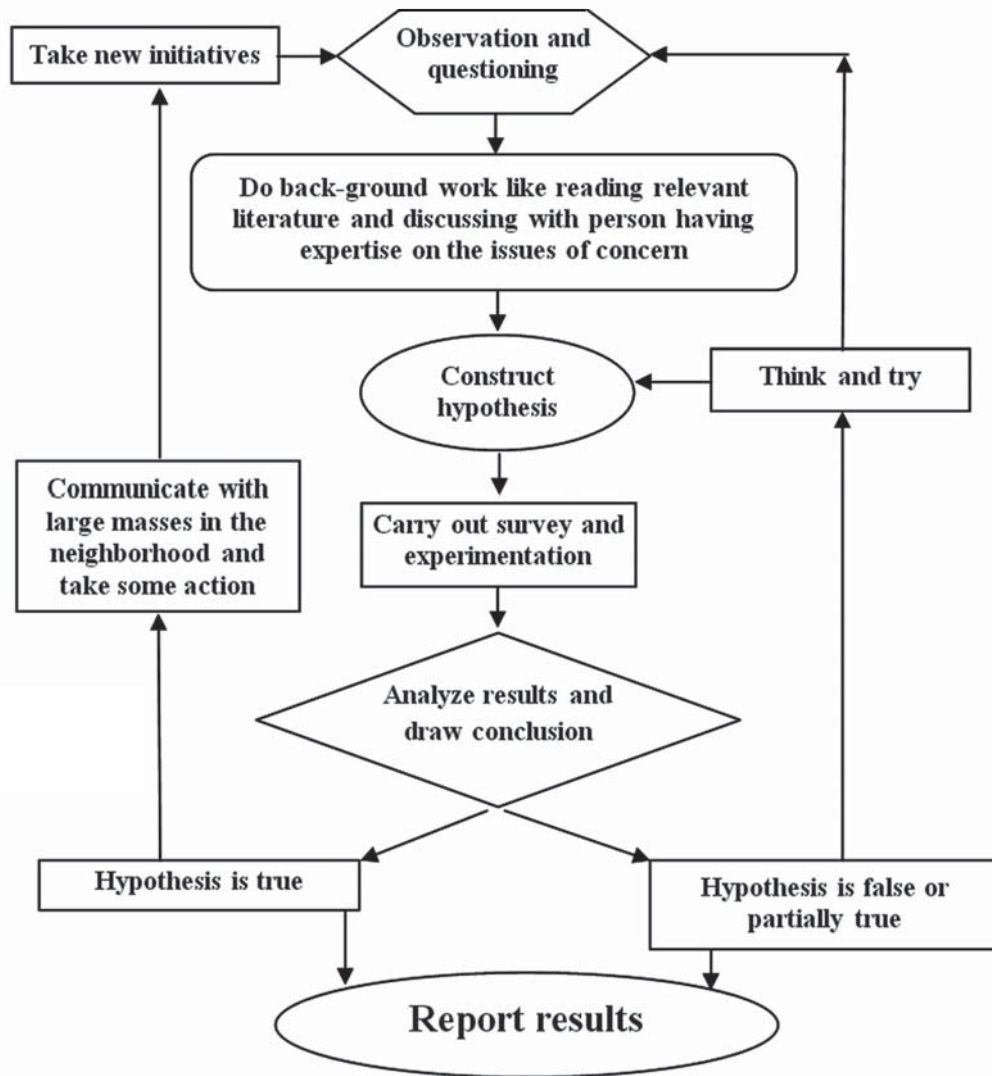

Therefore it is ideally expected that any group of children will undertake a project work with a perspective of continuous effort of questioning and experimentation as shown in Fig-1.

Here, observation incorporates anything the children observe in their daily life in the locality, in relation to the theme defined for the year. The observation should be followed by relevant questioning such as “What? Where? When? Why? How? Whom?”. In the search for finding out the answer to the question (s) one is required to review different literature concerning the issues in the study. Review of such literature basically and ideally helps in framing the steps towards the study and experimentation. In the process, one may also

discuss with experts of the relevant fields to get information and advice. Initiatives for such activities must be encouraged by the guide associated with the project. These steps will help to frame assumption/hypothesis.

Hypothesis is an assumption of some cause and its impact on the basis of observation, information collected from different literature and emerged from discussion with experts. After these phases, actual study through survey or experimentation or survey followed by experimentation would start. In the case of survey-based work, identification of respondent, their unit of observation, sample coverage, design of survey in relation to designing of interview schedule or

questionnaire is supposed to be the most critical steps. Such decisions may vary with the issues of study. On the other hand, in case of experimentation, setting the objective of experimentation, defining different parameters, identification of ideal instruments, framing of procedures/ steps and control along with repetitive observation of the experiments are critical decisions, which will determine the path towards the result. Again in relation to issues of study, such experiment may be either laboratory experiments or field experiments.

It is expected that in course of time, the children's project will bring in lots of new information about problems and prospects of their locality along with innovative ideas to address these issues. Moreover, in the course of project work, the children may develop different new approaches of study along with the development of different instruments for their experiments. Such tools/instruments may be developed with the material in their access/available to them nearby. Another expectation was that the outcome of different studies will be communicated among the local populace, which in turn, helps in generating scientific temperament among the general mass.

In a nutshell, the CSC projects are simple, innovative, concerned with local issues related with day to day life and are carried out with very nominal cost, where the focus is more on logical interpretation and analysis of issues, and finding out pragmatic solutions of generic nature to the possible extent, and not merely confined to the study topic and corresponding model making.

### **3. Objectives of CSC**

The primary objective of the Children's Science Congress is to make a forum available to children of the age-group of 10-17 years, both from formal school system as well as from out of school, to exhibit their creativity and innovativeness and more particularly their ability to solve a societal problem experienced locally using the method of science.

By implication, the CSC prompts children to think of some significant societal problems, ponder over its causes and subsequently try and solve the same using the scientific process. This involves close and keen observation, raising pertinent questions, building models, predicting solutions on the basis of a model, trying out various possible alternatives and arriving at an optimum solution using experimentation, field work, research and innovative ideas. The Children's Science Congress encourages a sense of discovery. It emboldens the participants to question many aspects of our progress and development and express their findings in their vernacular.

"A social movement along the lines of the Children's Science Congress should be visualized in order to promote discovery learning across the nation, and eventually throughout South Asia" – National Curriculum Framework 2005, Executive Summary, Page (ix)

### **4. Relevance of CSC in the light of contemporary educational initiatives**

The basic approach of CSC is the principle of learning through doing on the issues of children's immediate environment significantly carries the spirit and mandate of education for sustainable development (ESD) of UNESCO, National Curriculum Framework (NCF, 2005) and Right to Education (RTE, 2009).

The modalities and approaches of CSC cater to the five pillars of learning of education for Sustainable Development vividly, viz. Learning to know, learning to do, learning to live together and learning to be, learning to transform one self and society (Declaration of ESD in the 57<sup>th</sup> meeting of the United Nations General Assembly in December 2002, which proclaimed the UN Decade Education for sustainable Development, 2005-2014, refer – [www.desd.org](http://www.desd.org) and [www.unesco.org](http://www.unesco.org))

The mandate of CSC which encourages children to observe, explore, experiment and wonder through a

project activity and its associated ways of participation and evaluation rightly takes care of the guiding principles of the NCF, 2005. Therefore, example of children’s Science Congress has been rightly cited in the NCF documents under executive summary section, page ix (<http://www.teindia.nic.in/Files/NCF-2005.pdf>).

Similarly CSC activities also helps in materializing the approach of learning as framed in the Right of Children of Free and Compulsory Education (RTE)Act, 2005 [particularly in relation to article 6.1, section C (ii, iii, iv and v)].

More over the CSC activities, since 1993, has catered to many of the approaches and priorities of Science education visualized in the National Programme of Sarva Shiksha Abhiyan (SSA) (Ref:SSA framework, [http://ssa.karnataka.gov.in/pdfs/aboutus/ssa\\_framework%20.pdf](http://ssa.karnataka.gov.in/pdfs/aboutus/ssa_framework%20.pdf)) and RashtriyaMadhyamik ShikshaAbhijan (RMSA) (Ref:<http://www.educationforallindia.com/rastriya-madhyamic-shiksha-mission-RMSM.pdf>).

### 5. Eligibility Criteria for Participants

- It is open for children in the age of 10 years to 14 years (lower age group) and from 14+ years to 17 years (upper age group) as on December 31 of the calendar year.
- A group of children not exceeding five can do the project study under a guide teacher.
- A child scientist, who had already presented as a Group Leader at the National Level in one age-group can act as a co-worker in the subsequent year, in the same age group (lower / upper).
- Parents, whose child would participate in the Children’s Science Congress in the ensuing year, should not hold any portfolio in the organizing committee of the CSC conducted at any level.

### 6. Modalities of Participation

Following are major steps involved for participations in the CSC

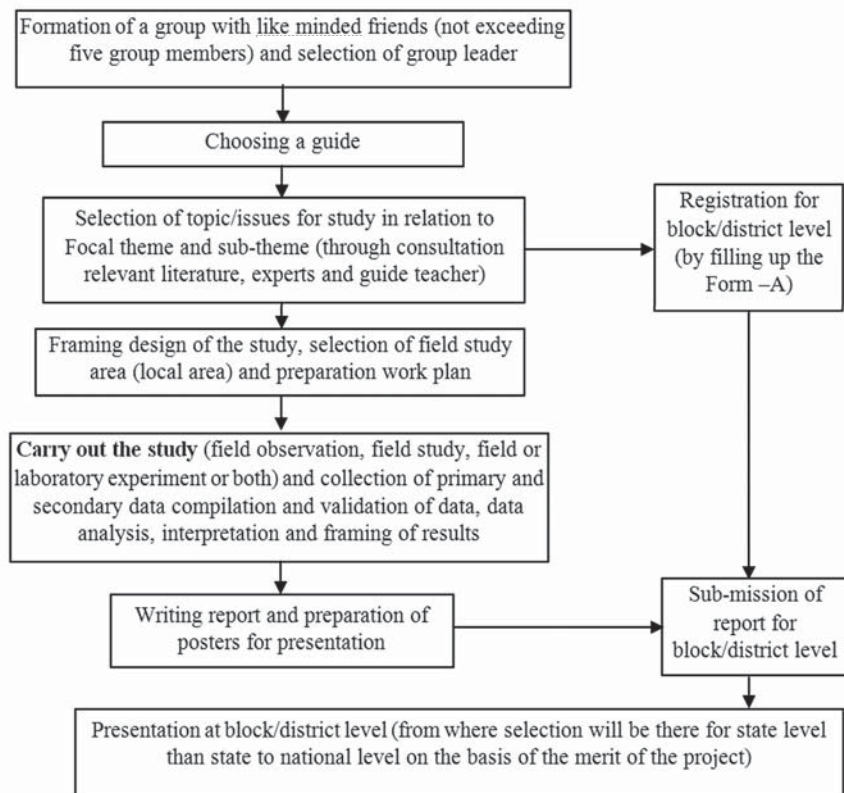



“A social movement along the lines of the Children’s Science Congress should be visualized in order to promote discovery learning across the nation, and eventually throughout South Asia” – National Curriculum Framework 2005, Executive Summary, Page (ix)

## 7. Nature of CSC Project

CSC projects are:

- Innovative, simple and practical;
- Representing teamwork;
- Based on exploration of everyday life-situations;
- Involving field based data collection;
- Having definite outputs, arrived through scientific methodology;
- Related directly to community work in the local community;
- Having follow-up plans.

## 8. Criteria of Good Projects

As per past experience it has been found that projects rated very good had the following elements while implementing and documenting the project:

- Proper understanding and definition of the problem undertaken.
- Quality and quantity of work, including team work, learning process, subject understanding and efforts to validate the data collected.
- Relevance of the proposal to the community/ school problem and impact of project on schoolmates, neighbourhood community.
- Originality, innovation and creativity shown to understand the problem and find solution i.e. in methodology and experiment design.

### The Project may follow the steps of SMART approach

**S: Specific:** The subject/issues of study must be specific.

**M: Measurable:** The issues of study must be measurable in quantitative /qualitative forms so that component of comparability is maintained.

**A: Appropriate:** The topic must be appropriate to the focal theme and sub themes, along with field study area, methodology must be appropriate to nature of the issues considered for the study.

**R: Realistic:** The issues of the study must be realistic along with the methodology adopted for the purpose.

**T: Time bound:** Study must be carried out in a limited time frame. The project activities may not destabilize normal activity /schedule of the child.

## 9. Points to remember

The project work of CSC must be carried out in a systematic way so that it can rightly reflect the method of science in the works. The issue of the study may demand experimental survey works or both. In case of experimental works design and principle of the experiments are very important factors which may help to get a better result in a rational way. In such case parameters of observation and verification through the experiment and its logical selection must be reflected vividly along with sets of control and approached of data validation. Similarly, in case of survey based projects universe of the study, criteria of selection, sample coverage, design of questionnaire or interview schedule are very important along with approached of data compilation, validation, analysis and interpretation. Prototype model or functional models are only encouraged to be used in project presentation if issues and methods of study demands for it.

**Log-Book.** Proper work diary has to be maintained while carrying out the project works. The day to day

activity has to be neatly noted in the form of a log-book and should be submitted with the project report at the time of submission. All the details, such as project title, name of the group leader etc. should be written clearly on the cover.

### 10. Structure of the Project Report

The structure of the project report of CSC shall be as follows:

- i. Cover page – must incorporate
  - Title of the project
  - Name and address of Group leader and co-workers
  - Name and address of guide
- ii. Form – A ( Registration Form)
- iii. Abstract – in 250 words for lower age group and 300 words upper age group (one copy in English) Please see Annexure VI for the Format for writing the Abstract.
- iv. Contents- list of chapter with detail heading and sub-heading, list of table, chart, maps, etc. along with references against page numbers
- v. Introduction- description on background of the study
- vi. Aims and objectives of the study
- vii. Hypothesis
- viii. Need statement & Relevance.
- ix. Methodology:
  - i. Experimentation,
  - ii. Survey (if related to the project, neatly describe Survey methodology followed, sampling procedure, Sample size etc.) Remember that projects having only a Survey component do not qualify to be an NCSC project and would be rejected. Survey can be an additional component of the methodology, to strengthen the project outcomes, to understand the Knowledge, Aptitude and Practices of the population).
- x. **Observations:** By this we mean what we

observe during the experiment, what outcomes are seen etc. Observation can be both qualitative as well as quantitative, but in NCSC, we mean quantitative mode where we end up having specific data from the experiments. Please note that observing some phenomenon is different in scientific parlance where every observation leads us to better understanding of the phenomenon, where we generate specific information as to when something happened, why, under what conditions and what /how much the change occurred.

- xi. **Data analysis and interpretation:** From the data that we generate /obtained from the experiments/observations, the data is processed for better understanding of the phenomenon in a more structured manner. We can use many tools and methods to analyse the data where we try to understand the patterns that emerge from it to form results and later conclusions. We need to remember that the raw data that is generated is not the Results, rather we use the raw data and interpret the data using tools /methods (eg. Statistical methods)..
- xii. **Results :** Results are the output of our compilation of the data into meaningful outcomes / interpretations and sometimes, we may need to redo the experiments to get consistent results. If in case, we are not able to “repeat the experiments”, we need to have adequate replicates so that adequate data is available for interpretation, and arriving at results.
- xiii. **Conclusions:** This is the logical end of the project where the experimenter tries to arrive at specific conclusions from the observed phenomena. In a way, the whole objective of the project was to arrive at some conclusion,

either positive or negative which would lead to a better understanding of the problem.

- xiv. **Solution to the problem:** Once the problem is understood using the above steps, then we can attend searching for solutions to the problems. Most often, the correct understanding of the problem would lead us to one or many solutions .
- xv. **Future plan** (Including any follow up plans): We can chalk out a future plan of action for taking the problem further, studying it deeper with more intensity and with more observations (replications, repeatations etc.)
- xvi. Acknowledgement
- xvii. References

The word limit for the written report for the lower age group is 2500 and that for the upper age group is 3500. The written report can be substantiated by including limited number of photographs, sketches, illustrations and / or drawings, etc.

## 11. Oral Presentation:

Oral presentation at the technical sessions of the congress is a very important component of the entire process. Effective communication during the briefing of the issues of study, its objectives, methodology adopted for the study, important observation and findings, vital aspects on the way and approach to solve the problem or addressing the problem is a very critical part of the exercise, since only 8 minutes' time is allotted for the purpose. Therefore, one has to plan pragmatically for this purpose. Children can use 4 different posters (which is mandatory) to make their presentation easier, clearer and richer. Posters must be prepared on 55 cm x 70 cm (21.6" x 27.5") drawing sheets (i.e. chart papers). If needed power point presentation may be used.

Your posters should contain bulleted points/information on (1) The project title, (2) Names of the

group members, (3) Objectives, (4) Map of the area, if any, (5) Methodology, (6) Results, (7) Conclusion, (8) Solution to the problem. Depending upon the nature of the project the poster may or may not have a map and/or results.

## 12. Different levels of Congress

Children's Science Congress is organized in three levels where the child scientists and their project works are screened under common evaluation criteria. The evaluation of the project is done for its **innovativeness, simplicity and practicality**. On the basis of the merit of the project is selected for the next level. The three levels are as follows:

- Block /district level
- State level
- National level.

The **District/Block level Congress** is the first level in which projects compete with one another and are screened for presentation at the **State level Congress**, which is the second level. Projects as per State-wise quota (indicated at Annexure- I) are selected from the State level for the Grand Finale – the **National Children's Science Congress**. Seven to eight lakh child scientists participate at various levels from the States and the Union Territories.

## 13. Screening

- (i) The selection ratio at District/State Level and at State/National Level should be as follows:

State: District = 1: 15

(Out of 15 projects presented at District 1 will be screened for State Level.)

- (ii) State to National As per State-wise quota indicated at Annexure-I. Projects qualified to take part in the National level are further divided in the ratio of 1:5, where the best projects at the

State level are qualified for Oral Presentation at the National level, whereas the rest of the projects that come to the National level are qualified for Poster Presentations. (See Annexure I for details).

- (iii) The selection ratio of Lower age group (10 to 14 years of age) to Upper age group (14+ to 17 years) should be 40:60. For National level, the State Academic Committee can decide which is the best project that would qualify for Oral Presentation irrespective of age group or Rural/Urban.

#### 14. Tentative Activity Schedule

- 1) Selection of subjects and activity for registration of teams : June-July
- 2) Working on the project: Minimum two months
- 3) District level Congress: By September-October
- 4) State level Congress: By November
- 5) National level Congress: 27-31 December
- 6) Indian Science Congress – 3 to 7th January.
- 7) 'Kishore VaigyanikSammelan' (at Indian Science Congress) from 3<sup>rd</sup> to 6<sup>th</sup> January.

#### 15. Approaches of Project Evaluation

The innovative ideas and scientific methodology are the basis of a good project but one has to prove his communication skills also to make others listen and understand his findings. For doing this, a total cooperation in the group is a must. Accept positive criticism within the group or even from outside and improve the work plan. This will bring award and recognition.

##### 15.1. Evaluation Criteria

- i. Originality of idea and concept:* A unique or novel project idea which attempts to answer a specific question - (a hypothesis driven by curiosity to understand any concept related to

focal theme). The idea should not be an exact replication of model project as printed in the Activity Guide. A proper explanation of origin of the idea may be demanded by the evaluator.

- ii. Relevance of the project to the theme:* This section focuses on how the project is relevant to the focal theme/sub-theme.
- iii. Scientific understanding of the issue:* Refers to the extent of knowledge the child scientist has in relation to the project idea.
- iv. Data collection:* Systematic collection of information using relevant tools/interviews/questionnaire. Sample size should be sufficient to support the issues under study.
- v. Analysis:* This includes tabulation, categorization/classification, and simple statistics as applicable to the study.
- vi. Experimentation/Scientific study/validation:* Conducting of experiments/field study and validation applying simple methods of science. Experiment need not be every sophisticated or lab based, they could be simple, self developed and inexpensive too.
- vii. Interpretation and Problem solving attempt:* To what extent the team has addressed the proposed hypothesis and the issue of the locality through the project.
- viii. Team work:* It refers to work division, cooperation and sharing among and beyond the team members (the child scientists).
- ix. Background correction (Only for District level):* In this case the background of the children is verified like geographical location of their school, village, town etc. in relation to infrastructure, information and other input related facilities available with them. The logic is that children from difficult geographical situation must get some weightage in comparison to the children from advantageous

geographical location. Non-school going children should also get some weightage in this criterion.

- x. Report and Presentation:** Written Report and Oral Presentation are evaluated separately. Reports are evaluated for its systematic presentation, tabulation of data in support of the project idea and the clarity with which the study is documented and explained. A **Log Book (actually a Daily Diary) is mandatory and should be authenticated over the signature of the guide teacher daily.** The cover page of the Log Book should carry the names of the child scientists, the district and the State, in English. Marks awarded for the presentation covers question and answer with evaluators, presentation of charts/posters, illustrations and other visuals.
- xi. Follow up Action Plan (Only for State level):** The child scientists should try to find out scientific solution to the bothering problem. Has the team conveyed the message to the community? How it was communicated? Will effort continue to involve more people till the problem is solved? Was any action plan suggested? Credit shall be given for similar efforts.
- xii. Improvement from the previous level (Only for State level):** This is to encourage the child scientists towards their continuous involvement with the project for its improvement. Improvements on the work from District to state level and then from State level to the national level will be given marks separately. The evaluators shall specify the areas of improvement on a separate sheet of paper.
- xiii. Additional page(s):** These must be there in the Project Report with detail description of works of improvement done after the previous level

(particularly on the basis of the evaluators' suggestion in the previous level).

## 15.2. Evaluators

- i. Evaluators may please note that the participating children are budding scientists from the age group of 10 to 17 years with limited access to knowledge centers and therefore require encouragement. Having understood their capabilities and capacities, the evaluators provide them with constructive inputs and positive feed-back.
- ii. Evaluators appreciate and value the efforts, innovativeness and confidence of the participating child scientists and ensure that their honest assessment work as a guiding light for future endeavors of the child scientists and each one goes back motivated, intellectually rich and more confident.
- iii. Evaluators should evaluate the projects on the basis of subject matter and scientific content and are not influenced by the gadgetry or models used or oratory skills of the participants. They avoid unwarranted comments and also avoid comparing the works of the child scientists with those carried out by senior members or scientists.
- iv. Evaluators should avoid being any source of distraction to the child scientists while presentation is going on and do not take the interactions with the participants as a test what the participating child does not know, rather, they make efforts to know what the child scientist know about the subject area.

**15.3. Model consolidated Evaluation Sheet (For District level)**

Sl. No.	Criteria	Max. marks	Written Report	Oral Presentation	Total
1.	Originality of idea and concept	10			
2.	Relevance of the project to the theme	10			
3.	Understanding of the issue	15			
4.	Data collection & analysis	15			
5.	Experimentation/validation	10			
6.	Interpretation and Problem solving attempt	10			
7.	Team work	10			
8.	Background correction	10			
9.	Oral presentation/ written report (as applicable)	10			

**Model consolidated Evaluation Sheet (For State level)**

Sl. No.	Criteria	Max. marks	Written Report	Oral Presentation	Total
1.	Originality of idea and concept	5			
2.	Relevance of the project to the theme	5			
3.	Understanding of the issue	15			
4.	Data collection & analysis	15			
5.	Experimentation/validation	10			
6.	Interpretation and Problem solving attempt	15			
7.	Team work	5			
8.	Follow up action plan	10			
9.	Oral presentation/ written report (as applicable)	10			
10.	Improvement over the previous level suggested	10			
	<b>Total:</b>	<b>100</b>			

### Model consolidated Evaluation Sheet (National level) with effect from 2014 onwards

1. The same team of evaluators will evaluate each project for Oral, Written and Poster presentations at one stretch.
2. More time would be allotted for the project evaluation – roughly 20 to 25 minutes – including 8 minutes for Oral Presentation, evaluation of the written report and the posters followed by interaction with the Team leader. With increased time available, the entire screening process would be in a relaxed manner and also in a child-friendly environ.
3. The parameters and attributes under each parameter for the national level evaluation are given below.

Sl. No.	Criteria	Max. Points
<b>A</b>	<b>Oral Presentation</b>	
1.	Originality of idea and concept	05
2.	Relevance of the project to the theme	05
3.	Understanding of the issue	05
4.	Data collection & analysis	10
5.	Experimentation/validation	10
6.	Interpretation and Problem solving attempt	05
7.	Oral Presentation	10
	<i>Sub Total – A</i>	<b>50</b>

Sl. No.	Criteria	Max. Points
<b>B</b>	<b>Written report</b>	
1	Data Collection /Analysis, Graphical Representation etc.	15
2	Methodology/Experimental design.	15
3	Discussion /Conclusion	10
	<i>Sub Total – B</i>	<b>40</b>
<b>C</b>	<b>Poster Presentation</b>	
1	Lay out	05
2	Logical Framework	05
	<i>Sub Total – C</i>	<b>10</b>
	<b>Grand Total (A+B+C)</b>	<b>100</b>

Thus each project would have total points of 100, out of which 50% would be for Oral presentation, 40% for Written Report and 10% for Poster presentation.

#### **15.4 Modified Evaluation Criteria for national level CSC**

- a. Every State Academic Committee need to be more proactive in the evaluation process at state level CSC and for this all SACs need to take appropriate action to strengthen their State Academic Committees with subject related persons and also having experience of the programme much more in advance. The SACs will be responsible for proper orientation of the experts, state level evaluators and mentors.
- b. Every project selected by the State Academic Committee for national will go through a quality mentoring process following which the State Academic Committee will evaluate the projects and grades to be awarded to each of the mentored projects. The grade sheet authenticated by State Academic Coordinator and State Coordinator is to be sent/ submitted to the National Academic Committee in a sealed confidential envelope. (sample of grade sheet is given in Annexure VII)
- c. Out of the projects which will be selected/ recommended from the state to take part in the National event, each state should recommend the **best** projects in the ratio of 1:5 of their respective state quota, which will be evaluated at the national level for **Oral Presentation**. Projects selected to the national level should be mentored by the State Academic Committee and the Post Mentoring Score Card for selected projects should be sent to the National Academic Committee (or submitted in person at the NCSC venue) at the time of the National evaluation process. (See Annexure VII for format). The rest of the projects would be qualified for **Poster**

**Presentations** as is normally followed in professional scientific conferences /seminar

- d. The selected projects from the states should be endorsed by the State Academic Coordinator and the State Coordinator so that the responsibility of projects being selected to the national level does not rest with the national academic core group.  
**(National Academic Core group would not be responsible in any way for any selection that is done by the respective State Academic Committee (SAC) or District Academic Committee (DAC) or Coordinators at the district or state level. Any query in this regard, would be attended by respective SAC or DAC).**
- e. Projects selected for oral presentation will be given certificate for Oral Presentation and the projects selected for poster presentation will be given certificate for Poster Presentation. Children who will qualify as outstanding after oral presentation will be given a 'Certificate of Merit'. However, all children irrespective of categories will be handed over medals/ mementos as has been done in the past.
- f. The objective of this modified evaluation process is to identify the most 'outstanding' projects. Hence, it is to be noted that this system will be followed at National Level only. At district and state levels the existing methods of evaluation has to be followed.

**It is MANDATORY for the projects selected for Oral Presentations at National Level to have the following;**

- i. **The cover page of the project should be either in Hindi or English.**
- ii. **Each project to have one page Abstract in English.**
- iii. **Four numbers of Posters as per the**



instructions provided in the activity guidebook.

- iv. Properly maintained Log book along with written report and posters.
- v. Post mentoring Score sheet for all the projects selected for Oral Presentation at the national level with the scores/grades awarded by the State Academic Committee. (See Annexure VII for details).

*These instructions are to be followed strictly else the project would not be evaluated at national level.*

## 16. Organizers

NCSC is organized by National Council for Science and Technology Communication (NCSTC), Department of Science & Technology, Government of India, with active support from NCSTC-Network, as a National Coordinating Agency. NCSTC-Network is registered Society, comprising a network of 79 organizations, Governmental and Non-governmental, spread over all the States and Union Territories of India, who are working for science popularization. To organize CSC at the State Level, each State/Union Territory has a coordinating body viz. State Coordinating Agency, which is a member of the NCSTC-Network.

### 16.1. Role of District Coordinating Agency, District Coordinators and District Academic Coordinators

- i. To agree in writing, on being selected, to act as a District Coordinating Agency and abide by rules and regulations prescribed in this Activity Guide Book and also by the State Coordinating Agency;
- ii. To constitute a District Organizing Committee and a District Academic Committee consisting of not less than 7 (seven) teachers, activists, ex-child scientists, government officials, officials of the local bodies etc. and send the lists to the State Coordinator by the date specified. The

District Coordinators shall act as the Member-Secretary of both the Committees;

- iii. To register groups of children (not more than 5 in one group) in Form A (**Annexure V**) and provide them with necessary reference materials, kits and guidance. No. of groups registered to be intimated to the State Coordinator by the date specified;
- iv. While registering the District Coordinator should be assured that the age of the child scientist falls within the age as on 31<sup>st</sup> December of the calendar year. If need be a copy of the age-certificate may be retained by the District Coordinator, to avoid any confusion at the later stages. Even while participating at the National Congress, the State Coordinator may also keep a copy of the certificate.
- v. To select schools from rural and urban area in an equal ratio;
- vi. To organize District level Teachers' Orientation Workshops with the help of the State Coordinators;
- vii. To interact with local scientist and arrange for their periodic interaction with the registered group of children, if required;
- viii. Try to involve at least 50 schools and 250 numbers of project in the district including those from informal education system;
- ix. Organize District level Congress, Orientation of Evaluators in consultation with the State Coordinators;
- x. To submit Feed-back Reports on all activities, containing names of schools and number of projects at district level and follow up action taken on projects likely to become part of community action, photocopies of all Registration/Attendance Sheets for all Workshops/Meetings, Evaluation Sheets in original, samples of certificates issued,

mementos presented to child scientists, photo-documentation etc. related to CSC at the District level to the State Coordinator in the manner and by the date specified;

- xi. To maintain a Bank Account and maintain Accounts at the District level and submit an audited Receipts & Payment Account to the State Coordinators by the date and in the manner specified;
- xii. To maintain infrastructural facilities, including electronic communication facility, such as internet connectivity, fax etc.
- xiii. To arrange review and mentoring of the projects selected for presentation at the State level NCSC.

### **16.2. Role of State Coordinating Agency, State Coordinators and State Academic Coordinators**

The State Coordinating Agency shall have the overall responsibility for the implementation of NCSC at the State level. The specific responsibilities shall be –

- i. Constitute a State Organizing Committee (SOC) and a State Academic Committee (SAC) where minimum 7 (seven) members to be selected from teachers, activists, ex-child scientists, government officials, officials of the local bodies, Network members in the State and other non-Network organizations specifically active in a region in the State, where the State Coordinating Agency does not have a reach. Submit the list of SOC, SAC, DOC and DAC along with Project Proposal for districts and state. The State Coordinators shall act as the Member-Secretary of both the Committees;
- ii. To constitute Regional Coordinators, if found necessary in case of big States and to involve SCERT, DIET, IRIS and organizations working with handicapped children/elder citizens and media representatives. Distribution of geographical

area for organizational purposes etc. will be the prerogative of the State Coordinators;

- iii. To locate individuals, schools specially interested in other curricular activities;
- iv. To select District Coordinating Agencies and obtain consent letter from the respective organization, where they have to agree to abide by the guideline of CSC and willing to follow the guidelines of NCSTC-DST, NCSTC-Network and State Coordinating Agency of the State;
- v. Organize Orientation Workshops of District Coordinators and teachers with the help of subject experts;
- vi. To coordinate translation of the Activity Guide Book to be used by the children, in local language and make them available to the District Coordinators. To separately print/photocopy Activity Guide Book for participating child scientists and give them on cost to cost basis;
- vii. To maintain a Bank Account and maintain Accounts at the State level and submit an audited Receipts & Payment Account to the funding agencies within three months of the date of event with a Project Completion Report and a Utilization Certificate in the manner prescribed;
- viii. To submit Feed-back Reports on all activities, samples of certificates issued, mementos presented to child scientists, photo-documentation etc. related to CSC at the State level to the funding agency in the manner and by the date specified;
- ix. To remit funds to District Coordinating Agencies by account payee cheques;
- x. To form linkages with Testing and Monitoring facilities available in the State (with NGOs as well as Government), Municipal Corporations and other local bodies etc. to help children in better implementation (information collection/sample

testing) of their activities (Identity Cards may be issued to children registered for activities) through District Coordinators/State Coordinators;

- xi. To arrange review and monitoring of the projects selected for presentation at the NCSC.
- xii. To ensure that Evaluation sheets, both written and oral are forwarded to the next higher level, i.e. from district to State and from State to National level, else the district / State contingent might not be registered during State/National level CSC.
- xiii. State Academic Coordinators should work in close association with the district/State Coordinators for arranging evaluation process and shall make an effort to send one member from State Academic Committee as an Observer to the district level CSC. His/her signature on the selection list is mandatory. The entire process of evaluation is to be supervised by the Observer. Decision of the State Academic Committee shall be final word on the selection.

### **16.3. Note for State Coordinators and District Coordinators**

- i. The age limits for participation must not be less than 10 years and more than 17 years on December 31 of the year.
- ii. Relatives of District Coordinators, District Academic Coordinators, State Coordinators and State Academic Coordinators will not be selected for National CSC. They may leave the post for the year if participation of the ward is desired.
- iii. A child will not participate more than twice in national CSC as Group Leader – once from each age group.
- iv. Two selected projects (one from lower age group and the other one from upper age group) from each State **are to be** selected to participate in **‘Kishore VaigyanikSammelan’ of the Indian**

**Science Congress** session held every year **during 3<sup>rd</sup> to 7<sup>th</sup> of January.**

- v. CSC projects meeting the following criteria may apply Technology Entrepreneurship Promotion Program selected for support–
  - The idea should be new/novel,
  - The idea should have potentiality for translating it into working model / prototype/process,
  - The idea should be based on known scientific principle,
  - The idea should have commercial feasibility/ technical viability.
- vi. Proposals from individual innovators to convert an original idea / invention / know-how into working prototype / processes. These proposals can be made by individuals or jointly with any sponsoring organizations.
- vii. Selected projects will be provided by financial support to undertake the above developments, patent support and guidance, scientific / technical consultancy, fabrication assistance, market information and networking with related research lab/ institutes as required. For detailed information you may contact:

**Techno-entrepreneur Promotion Programme,  
Ministry of Science & Technology, Post Bag  
No. 66, HauzKhas, New Delhi 110016.**

**For further details please contact :  
State Coordinator of  
your respective State / Union Territory.  
(See Annexure II)**

**Dr.B.P.Singh,**

Scientist G & Head,  
National Council for Science & Technology  
Communication (NCSTC),  
DST, Govt. of India.

**Dr.D.K.Pandey,**

Scientist F & National Programme Coordinator of  
NCSC,  
National Council for Science & Technology  
Communication,  
Department of Science & Technology, Technology  
Bhavan, New Mehrauli Road  
New Delhi-110016.  
Email: dkp@nic.in ; Telephone: 011-26535564 /  
26590251.

**Er.Anuj Sinha**

Chairperson, NCSTC Network  
Mobile: +91- 9717048666  
Email: cpranuj@yahoo.com

**Mr.Khwaja Rafi,**

General Secretary, NCSTC Network  
E-56, 1st. Floor, Samaspur Road, Pandav  
Nagar, New Delhi 110091, Mobile: 0-9873717806  
Email: kmrafi1@gmail.com ,  
ncstcnet@hotmail.com;

**Mr.T.P.Raghunath**

Chairman, National Academic Committee  
Pondicherry Science Forum  
Mobile: +91-94432-25288, Email:  
tprmenon@gmail.com

**Some important points for Participation in the Indian  
Science Congress's 'Kishore VaigyanikSammelan'**

Any one of the co-workers (preferably the second in the team) of the selected two best projects of the State level Congress (one from lower age group and the other one from upper age group) will participate in this programme.

This session is a poster presentation session, so following aspects have to be taken care of for participation:

- i. Use four posters which were used earlier in the State Congress (as suggested by the evaluators in the State Congress and the mentors. Those may be improved).
- ii. The posters must use English along with children's own language.
- iii. Keep a copy of the Project Report.
- iv. You shall also have to keep copies of abstract in English separately (for distribution if required) with details of the all team members, teacher guide and the State represented mentioned clearly).
- v. Posters should be designed in such a way that the contents are readable from a considerable distance and to also to ensure that excess use of colours do not create hurdles in reading and viewing.

*Part 2*



UNDERSTANDING  
WEATHER AND CLIMATE



# Focal Theme

## Understanding Weather & Climate

Weather is the instantaneous state of the atmosphere, or sequence of states of the atmosphere with time, which can be defined as the condition of the atmosphere at any given time and place. Climate, on other hand, is the average as well as variability of weather conditions prevailing in an area over a long period of time; it can, in short, be viewed as the Statistics of Weather.

Precipitation, temperature, humidity, atmospheric pressure, and wind are the important elements of weather and climate. It is the result of the interaction of four basic physical elements- the Sun, the Earth's atmosphere, the Earth itself, and natural landforms on the Earth's surface.

## Why is Earth getting warmer?

Global air temperatures near Earth's surface rose almost one and one-half degrees Fahrenheit in the last century. Eleven of the last 12 years have been the warmest on record. Earth has warmed twice as fast in the last 50 years as in the 50 years before that. Even a small rise in Earth's global temperature means melting ice at the North and South Poles. It means rising seas and flooding in some places and drought in others. It means that some plants and animals thrive while others starve. It can cause big changes for humans too. One and one-half degrees may not seem like much. But when we are talking about the average over the whole Earth, lots of things start to change. Carbon dioxide is a greenhouse gas which traps heat from Earth's surface and holds the heat in the atmosphere. Scientists have learned that, throughout Earth's history, temperature and CO<sub>2</sub> levels in the air are closely tied.

*This graph shows carbon dioxide levels over the past 450,000 years. Notice the sharp increase starting around 1950.*

*Ref: <http://www.ncdc.noaa.gov/paleo/globalwarming/temperature-change.html>.)*

As you can see, for 450,000 years, CO<sub>2</sub> went up and down. But CO<sub>2</sub> levels never rose over 280 parts per million until 1950. But then something different happens and CO<sub>2</sub> increases very fast. At the end of 2012, it is 394 parts per million mainly because of burning of fossil fuel.

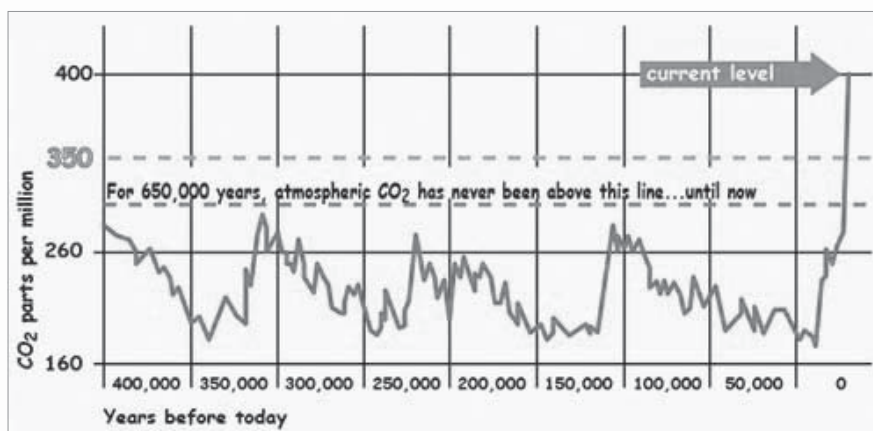

Now, let's look at that graph again, but adding the temperatures for that same period of Earth's history.

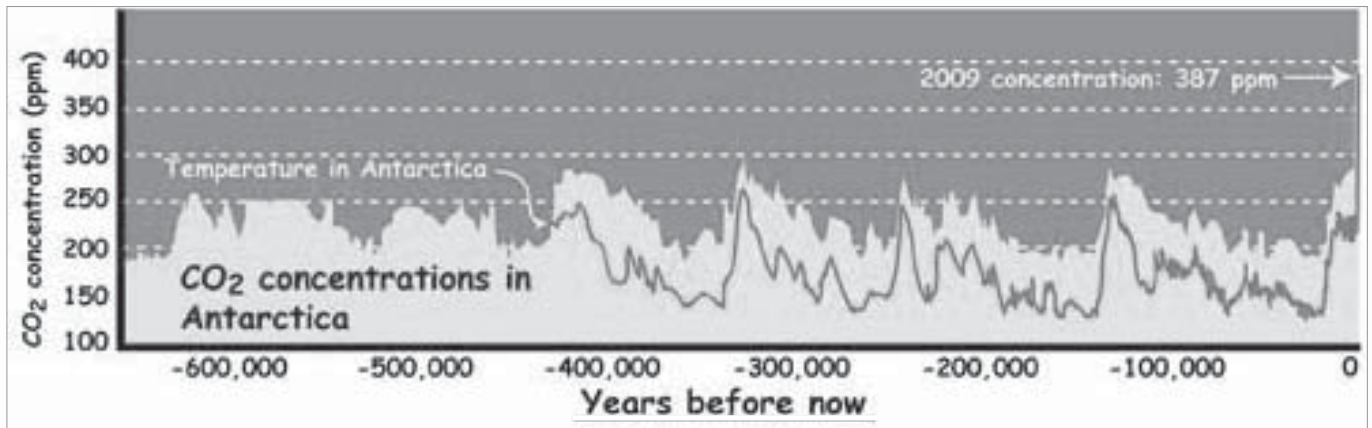

This graph shows how carbon dioxide and temperature have risen and fallen together in Antarctica over the past 400,000 years.

Ref: [http://www.epa.gov/climatechange/science/pastcc\\_fig1.html](http://www.epa.gov/climatechange/science/pastcc_fig1.html).

\* Reference NOAA's Earth system Research Laboratory, Global Monitoring Division, <http://www.esrl.noaa.gov/gmd/ccgg/trends>, <http://climatekids.nasa.gov/greenhouseeffect>

Water can soak up a lot of heat. When the oceans get warmer, sea ice begins to melt in the Arctic and around Greenland. NASA's Earth satellites show us that every summer some Arctic ice melts and shrinks, getting smallest by September. Then, when winter comes, the ice grows again.

But, since 1979, the September ice has been getting smaller and smaller and thinner and thinner.

As more sea ice and glaciers melt, the global sea level rises. But melting ice is not the only cause of rising sea level. As the ocean gets warmer, the water actually expands! Sea level has risen 6.7 inches in the last 100 years. In the last 10 years, it has risen twice as fast as in the previous 90 years. If Greenland's ice sheet were to melt completely, sea level all over the world would rise by 16-23 feet (5 to 7 meters).

### What is a greenhouse?

A greenhouse is a house having glass walls and a glass roof used for growing vegetables and flowers. A greenhouse stays warm inside, even during winter. Sunlight shines in and warms the plants and air inside. But the heat is trapped by the glass and can't escape. So during the daylight hours, it gets warmer and warmer inside a greenhouse, and stays pretty warm at night too. Earth's atmosphere does the same thing as the greenhouse. Gases in the atmosphere such as carbon dioxide do what the roof of a greenhouse does. During the day, the Sun shines through the atmosphere. Earth's surface warms up in the sunlight. At night, Earth's surface cools, releasing the heat back into the air. But some of the heat is trapped by the greenhouse gases in the atmosphere. That's what keeps our Earth a warm and cozy 59 degrees Fahrenheit, on average.

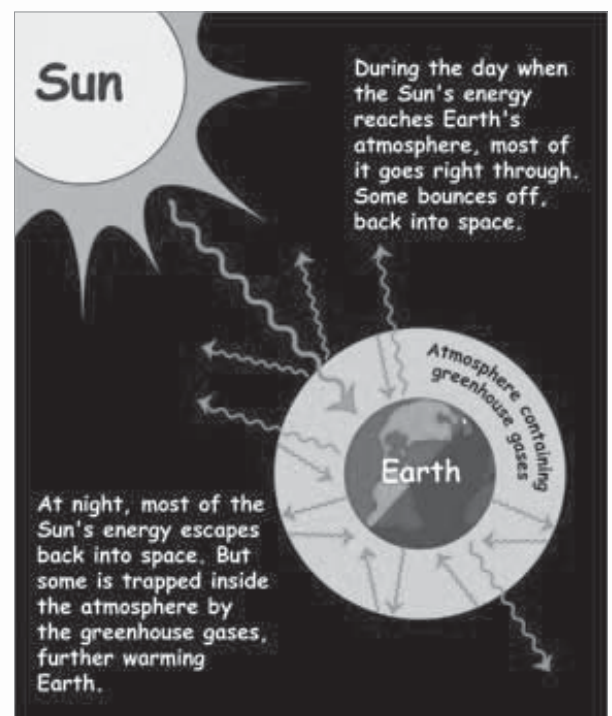



Greenhouse effect of Earth's atmosphere keeps some of the Sun's energy from escaping back into space at night.

If the atmosphere causes too much greenhouse effect, Earth just gets warmer and warmer. This is what is happening now. Too much carbon dioxide and other greenhouse gases in the air are making the greenhouse effect stronger.

### Why are they called fossil fuels?

Because the fuel in your gas tank comes from the chemical remains of prehistoric plants and animals! All living things on Earth contain carbon. Even you contain carbon. Lots of it. If you weigh 100 pounds, 18 pounds of you is pure carbon! And plants are almost half carbon!

### How does carbon get into living things?

Plants take in  $\text{CO}_2$ . They keep the carbon and give away the oxygen. Animals breathe in the oxygen and breathe out carbon dioxide.

Plants and animals depend on each other. It works out well. For hundreds of millions of years, plants and animals have lived and died. Their remains have gotten buried deep beneath Earth's surface. So for hundreds of millions of years, this material has been getting squished and cooked by lots of pressure and heat.

For hundreds of millions of years, dead plants and animals were buried under water and dirt. Heat and pressure turned the dead plants and animals into oil, coal, and natural gas.

### How does the carbon get out of living things?

When fossil fuels burn, we mostly get three things: heat, water, and  $\text{CO}_2$ . We also get some solid forms of carbon, like soot and grease.

So that's where all the old carbon goes. All that carbon stored in all those plants and animals over hundreds of millions of years is getting pumped back into the atmosphere over just one or two hundred years. Did you know that burning 6.3 pounds of gasoline produces 20 pounds of carbon dioxide?

### Is carbon in the air good, bad, or just ugly??

A greenhouse traps the Sun's energy inside and keeps the plants warm.

Here's the big, important thing about  $\text{CO}_2$ : It's a greenhouse gas. That means  $\text{CO}_2$  in the atmosphere works to trap heat close to Earth. It helps Earth to hold on to some of the energy it gets from the Sun so the energy doesn't all leak back out into space.

If it weren't for this greenhouse effect, Earth's oceans would be frozen solid. Earth would not be the beautiful

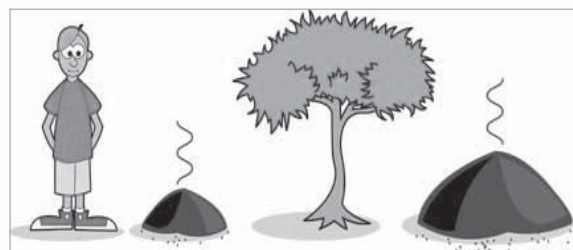
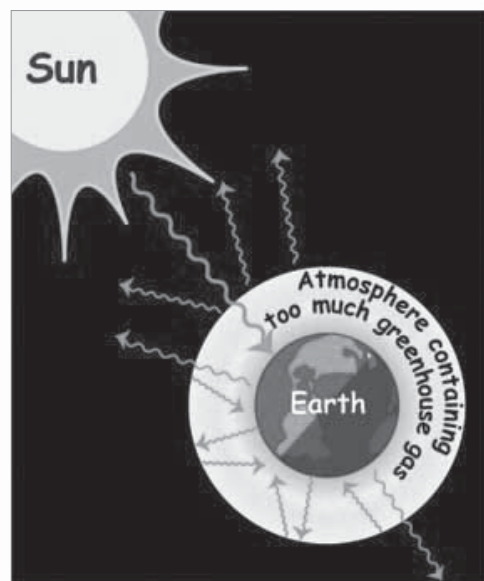

*You are 18 percent carbon. Plants are 45 percent carbon.*

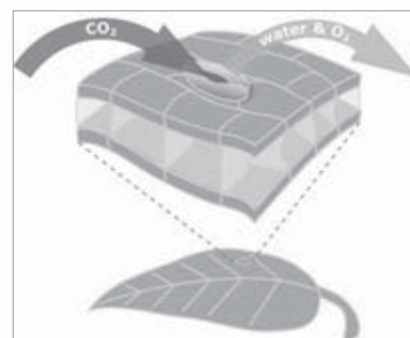

*Carbon dioxide in, water and oxygen out.*

blue and green planet of life that it is. If not for the greenhouse effect, Earth would be an ice ball. So, CO<sub>2</sub> and other greenhouse gases are good—up to a point. But CO<sub>2</sub> is so good at holding in heat from the Sun, that even a small increase in CO<sub>2</sub> in the atmosphere can cause Earth to get even warmer.

The geographical situation of any locality/area/region in relation to its latitudinal and longitudinal position, altitude, distribution of land and water, relative location from water bodies, surface cover (viz. vegetation/snow/rocks etc.) are some of the natural factors that influence the weather and climatic condition of that particular location.

Likewise, weather and climate are among the factors that determine the nature, condition, and pattern of natural resources (e.g. water, soil, flora, and fauna). State of temperature, humidity, and precipitation in temporal context in a year determine season and climatic condition in long temporal context. These are



responsible for determining the forms of water, soil-forming processes and creating support systems for floral growth; which again determine the faunal composition. These natural resource bases along with weather and climate determine our way of life (viz. occupation, housing, food habits, dress style, transportation, etc.) to some extent. In totality, weather and climate influence the base of the economy and culture of that area. In this perspective, any significant as well as rapid change in weather and climatic condition creates serious impact not only on natural resources but also on the biosphere as a whole, including human life.

Scientists have studied global climate change patterns, apparent from mid to late 20<sup>th</sup> century onward, attributed largely to increased levels of atmospheric carbon dioxide produced by uses of fossil fuels and other greenhouse gases. Averaged over all land and ocean surfaces, temperature has increased by **roughly 1.53°F (0.85°C) from 1880 to 2012**, according to the Intergovernmental Panel on Climate Change (the IPCC's *Climate Change 2013: The Physical Science Basis*, Summary for Policymakers, Page 5. The Intergovernmental Panel on Climate Change (IPCC) is the leading international body for the assessment of climate change. It was established by the United Nations Environment Programme (UNEP) and the World Meteorological Organization (WMO) in 1988 to provide the world with a clear scientific view on the current state of knowledge in climate change and its potential environmental and socio-economic impacts and was endorsed by the UN General Assembly. It produces detailed reports on Climate Change once every five years, based on hundreds of peer reviewed studies. Its Fifth Assessment Report is getting finalized now.)

Above graph shows the average temperature on land and ocean together as it has changed from 1880–2013. Zero degree here is the average mean temperature between 1951–80. The black line is the annual mean and the red line is the 5-year running mean. This five year moving average line makes it easier to see the temperature trend over the years after the industrial revolution. Source: NASA GISS

This climate change is considered as one of the most important global environmental challenges being faced by humanity today, with its implication on natural ecosystem, food production systems, fresh water supply, health and weather related calamities.

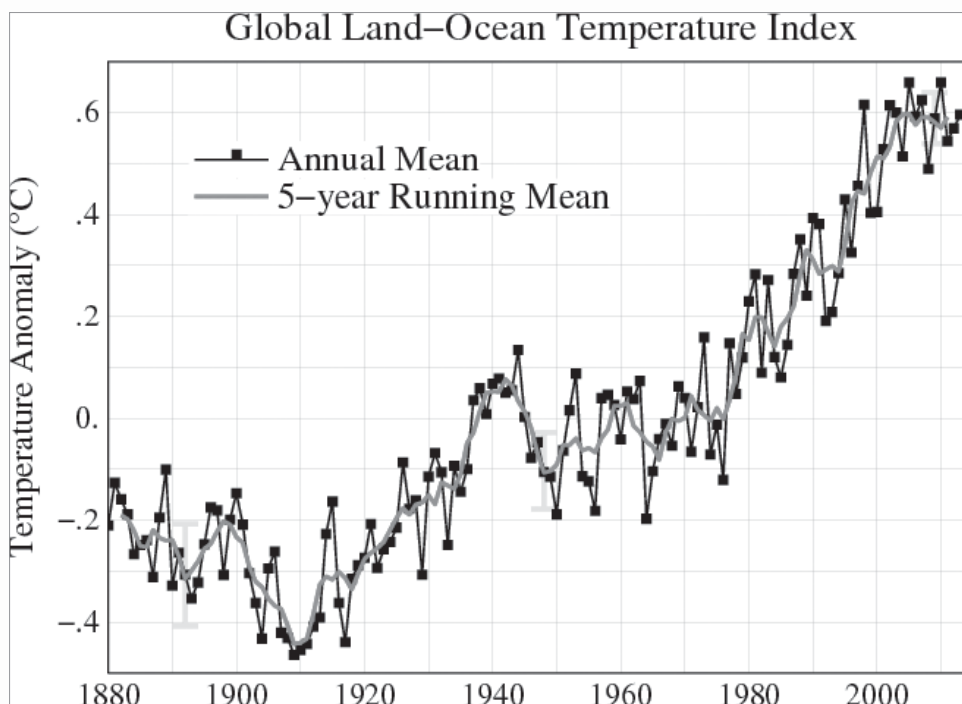

India's weather and climatic conditions are naturally controlled by her geographical location (i.e. its latitudinal and longitudinal extents) and the conditions along her boundaries. (Himalayan ranges from northwestern to northeastern corner in the northern side, existence of Indian Ocean and Arabian Sea as well as Bay of Bengal in southwest to southeast).

The country also encompasses the Western Ghats, which is one of the 34 Biodiversity hot-spots of the world; extending along the West coast of India from the VindyaSatpura ranges in the North to the Southern tip of the peninsula to a stretch of 1,600 km, receiving an average of nearly 6000 mm of rainfall every year.

The latitudinal and longitudinal extension within the country has greater implication on variation of solar days or sunshine hours from east to west, which is one of the fundamental factors regulating weather and climatic variations in the country. Further, within the country, there are variations in distribution of land and water, altitudinal differences, vegetation type and coverage. All these together have given rise to six different climatic zones and twelve agro-climatic zones.

However, these climatic and agro-climatic zones are facing serious problems of various kinds due to the impact of climatic/ weather changes. For more than a decade, weather and climatic anomalies are taking place in all the agro-climatic regions of the country. Moreover, winds during monsoon mainly control Indian climate; highly influenced by the summer monsoon. But in the last few decades, onset of monsoon over India is changing resulting in variations in the amount and distribution of rainfall.

While weather and climate impact living conditions of humans, humans too impact climate through their actions. This is partly because of the rapid growth of their population in the last century. But it is largely due to the manner in which humans – mainly in developed countries – have started exploiting natural resources including coal and oil in an increasing manner to produce all kinds of goods and services to lead a life they consider to be comfortable. In 2009, a group of eminent scientists identified planetary boundaries – safe operating limits, which, if crossed risk



irreversible and abrupt environmental change - for nine earth system processes like fresh water use, land use, biodiversity loss, ocean acidification and such other. They found that these boundaries had already been crossed in biodiversity loss, climate change and Nitrogen cycle. ("Planetary Boundaries: Exploring the Safe Operating Space for Humanity", Rockström, J and 28 others, *Ecology and Society*14(2): 32. [online] URL: <http://www.ecologyandsociety.org/vol14/iss2/art32/>). There is substantial risk of climate change, being caused by human action in increasing manner each year, getting out of hand. This focuses attention on what steps humans need to take now to save their future generations, along with other species on earth.

### **Need to Study Weather and climate**

In this context, there is a need to have proper understanding of weather and climate and its changes, mainly oriented towards different aspects, factors, and attributes of weather and climate along with their

implications on the natural ecosystem, on society and culture and on human health. Right through, there needs to be focus on climate change aspects, including mitigation and adaptation. As children, a proper understanding of these issues are of utmost importance to have a scientific approach as well as attitude to low carbon routes of development, livelihoods, lifestyles etc.

With this aim, the main focal theme of Understanding Weather and Climate will have the following sub themes under which children can carry out projects.

Sub Theme 1 : Understanding Weather around you.

Sub Theme 2 : Human Impacts on Weather and climate.

Sub Theme 3: Weather, Climate and Ecosystems.

Sub Theme 4: Weather, Climate, Society & Culture.

Sub Theme 5: Weather, Climate and Agriculture.

Sub Theme 6: Weather, Climate and Health.

Each of the Sub themes would be elaborated in the next sections.

It may be noted that Sub Theme 1, which is Understanding Weather around you, becomes the basic experimental framework for all the other Sub Themes as NCSC projects should always have an experiment and thus for any project in any of the Sub Themes, Understanding the Weather - measuring the local weather parameters are mandatorily to be carried out. It may also be noted that an NCSC project can have more than one Sub Theme combined if necessary according to the specific problem being addressed.



*Sub Theme 1*

**UNDERSTANDING  
WEATHER AROUND YOU**



# Understanding Weather Around You

## Observing, Measuring, Understanding and Predicting It

### Background

Weather is ubiquitous. You cannot ignore it. We live “inside”. We may feel it. We complain against it. But we often take it for granted and not care about it. This could be dangerous. We need to understand the weather, measure its parameters and see if we can predict for us to even *survive*. It is a historical fact that we created calendars to predict weather. How can we understand the details about our local weather? How do we make observations on the weather? Do we follow the same steps our distant forefathers did? Can we find new ways? Can we learn from modern scientific methods for our local use?

### Why is weather important?

Weather affects all things around us. Whether it is crop production, insects biting us, diseases crippling us, fruits we eat, flowers we smell all respond to weather.

So, we think you will all agree we need to learn more about the weather that is everywhere around us.

Weather is what we feel today. Now if you can imagine yourself living for a hundred years and you remember all the days of your life and how the weather was on each of those days, then you would tell your great-grandchild that “in my days in July it was like this”—You have talked about the “climate”. Climate is an “averaged” view of weather over a long time – typically from few years to millennia.

Weather is made up of several interlinked parameters – such as, temperature, humidity, wind speed/direction at different atmospheric levels. Of course, these are all influenced by geography(latitude, longitude), distance from the sun, solar activity, sunrise, sunset,(day length) sun’s position etc.

So what can all of us do to learn more?

### Framework

Our objective is to be able to

- (i) decide what aspect/parameter of weather or its manifestation(s) we want to observe/measure/understand/predict;
- (ii) decide what methods we should adopt for this purpose
- (iii) decide on instruments we could use/build for the above purpose
- (iv) report/record our observations/measurements
- (v) analyse the data we gather
- (vi) predict what might happen in the future

## Importance

As already stated in the background above, it is important that we are able to predict weather as ignorance of it may be costly. Knowledge is power. Those who know survive and prosper. Simple extrapolation would be dangerously unsuccessful. To predict we need to know what it is now and what it was earlier so we can develop methodology. As all of us have felt at one time or another weather can really make our life difficult – whether it is cyclones, tides or tornadoes. Only knowledge will let us know what the probability we may be wrong is!

## How to Proceed?

We propose a series of simple-to-do experiments exemplifying each/some of the parameters that you children can do and learn from. The experiments should be of such a nature that you can think it through and come up with innovative ways of doing it. The experiments would be so designed that they bring out information on the quantity, magnitude of the factor/parameter, changes in its values over time, and how it links to other parameters. Ultimately, this would allow the child to understand and describe the parameter and its role in defining the weather and its implications for us.

## Components

The experiments would involve, *inter alia*, observations, measurements of different parameters of interest. The observations would push the child to integrate and synthesis the data into a set of linked proposals(hypotheses). The child would, ideally, at the end of the experiment, come up with a conclusion based on evidence which will be of some consequence. The components/ parameters/ aspects that could be studied are:

- Temperature [ maximum, minimum, average]
- Atmospheric pressure
- Wind Speed and wind directions
- Relative Humidity
- Clouds
- Quantum, Intensity and Frequency of Rain
- Lightning, thunder, rainbow
- Tides [in coastal regions]
- Water level [in wells, ponds]
- Evaporation from surface water
- Fog, mists and smog and dew
- Response of Plants and insects to weather
- Predicting weather from plants and animal behavior
- Emergence of diseases

Weather and climate influence many socio-economic and development patterns of a region and thus has become one of the most important environmental parameters. Weather and climate decide almost everything about our way of life including our occupational and recreational practices and this critical role is often not taken into account by planners while siting industries and power stations and making decisions on transport and other infra-structure for a region.



There is hardly any human activity that is not in one form or another influenced by weather and climate. In a country like India where rainfall is highly seasonal and agriculture is largely dependent on the rainfall of the summer monsoon months, viz., June to September, the national economy has become crucially dependent on the behaviour of monsoon. Vagaries in the monsoon rainfall resulting in large scale floods and droughts seriously affect the annual food production of the country besides causing loss of lives and damage to property. Heavy rainfall and strong winds associated with cyclonic disturbance cause disruption and dislocation of transport and communications and loss of life and property.

The siting of industries, thermal power stations, oil refineries etc., which emit gaseous and other particulate pollutants into the atmosphere has to take due consideration of the prevailing wind and atmospheric stability conditions during the course of the year to minimize the harmful effects of the atmospheric pollution and contamination. With large scale establishment and expansion of industries throughout the country especially in the coastal belt, the protection of the environment (land, sea and air) from the harmful chemicals into the environment by man-made factors has become a matter of concern. There is apprehension that unless preventive measures are taken, this may lead to irreversible ecological imbalances and climatic changes.

The local weather and climate of a station are of interest to the residents in general since it concerns their day-to-day lives. Besides, it also influences their clothing, food habits, working styles and recreational practices. Dislocation of transport, communication, power and water distribution is a common occurrence in most states during during heavy spells of monsoon. Little can be done about gusty strong winds during pre-monsoon which uproot trees and fell electric poles year after year.

Planners require weather information for design, execution, management and control of major industrial, commercial, and other activities in and around their chosen sites. Information about local weather parameters and their seasonal variations is needed for siting of runways, railways and road network.

### **Structure and composition of the Atmosphere:**

- ❑ Meteorology is the study of the atmosphere and all processes and phenomena that results in our particular weather.
- ❑ Different branches of Meteorology are
  - Climatology
  - Synoptic Meteorology
  - Dynamic Meteorology

### **Composition of the Atmosphere:**

The major gases in the atmosphere are nitrogen which constitutes about 78% and then oxygen which constitutes about 21% of the atmosphere. Further there is presence of Argon which is present by about 0.93% and then trace gases such as Hydrogen, Krypton, Methane, Helium, Neon, carbon dioxide and water vapour etc. Figure and the table given below explains the atmospheric composition.

Figure . Composition of the atmosphere.

Principal Gases of Dry Air

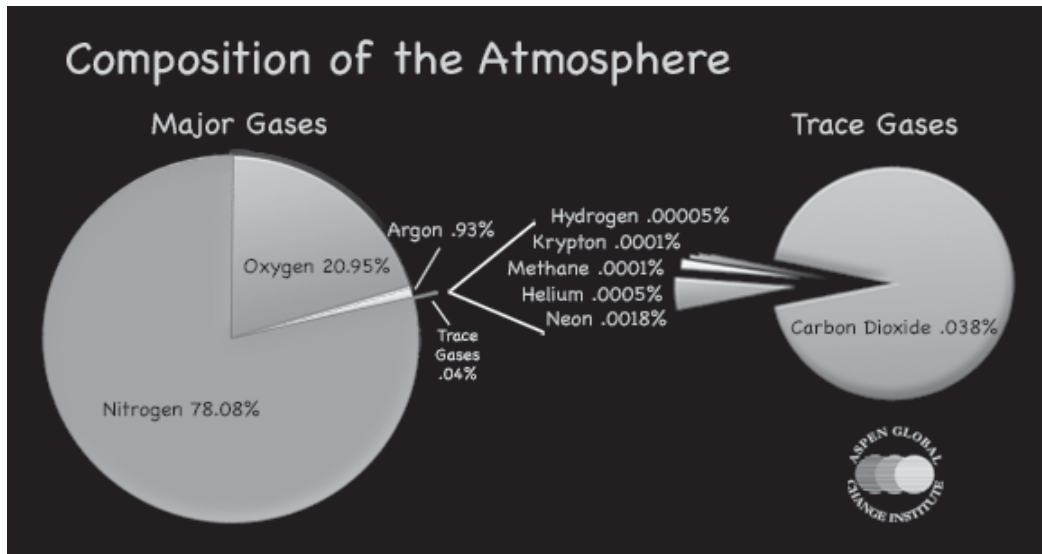

Constituent	Percent by Volume	Parts per million (PPM)
Nitrogen (N <sub>2</sub> )	78.08400000	7,80,840
Oxygen (O <sub>2</sub> )	20.94600000	2,09,460
Argon (Ar)	0.93400000	9,340
Carbon Dioxide (CO <sub>2</sub> )	0.03800000	380
Neon (Ne)	0.00182000	18.20
Helium (He)	0.00052400	5.24
Methane (CH <sub>4</sub> )	0.00015000	1.50
Krypton (Kr)	0.00011400	1.14
Hydrogen (H <sub>2</sub> )	0.00005000	0.50

Further, the atmosphere is layered into different regions such as troposphere, stratosphere, mesosphere and thermosphere etc. Figure gives the different layers in the atmosphere such as troposphere, tropopause, stratosphere, stratopause, mesosphere, mesopause etc along with altitude and temperature.

**Troposphere:**

- The troposphere varies in height from Surface to 10 -18 km
- 90% mass of the atmosphere
- Normal temperature lapse rate – average cooling at rate of 6.5 ° C / km
- Most of the weather phenomena occurs in the troposphere.
- Stratosphere varies from 18 to 50 km; Mesosphere varies from 50 to 80 km and Thermosphere region varies from 80 km outwards

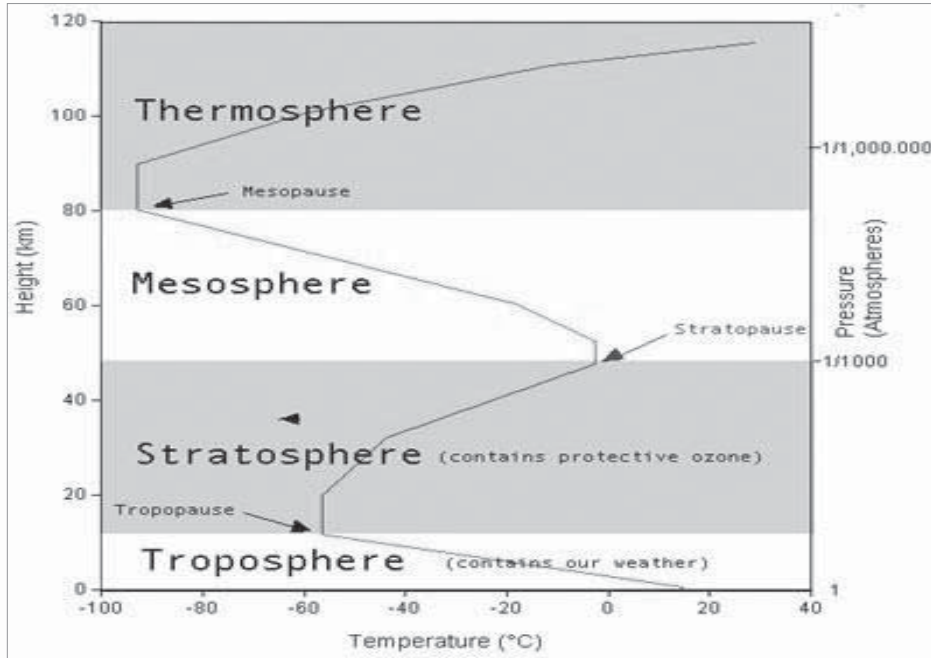

- Weather is constantly changing, sometimes from hour to hour and at other times from day to day.
- Basic weather elements are;
  - Air temperature
  - Air pressure
  - Wind speed and direction
  - Humidity
  - Precipitation

**Measuring weather parameters over different regions.**

**Temperature:**

A thermograph measure the temperature of the surrounding region Figure 1 gives the thermograph used for measuring the temperature.

*Figure 1. Thermometer used for measuring temperature.*



**Rainfall**

A rain gauge measures the rainfall over different regions. Figure 2 gives rain gauge which is used to measure the rainfall over different regions.

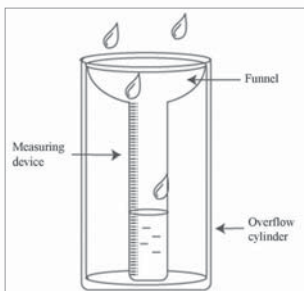

*Figure 2: Raingauge used for measuring the rain.*

## Wind speed and wind direction :

Winds play an important role in weather and climate as they decide the fate where how the pollutants are dispersed in the atmosphere. Further the land and sea breeze phenomena an important role in the land and sea circulation in coastal areas. Further they also decide how the mixing takes in the low troposphere.

An Anemometer measures the wind speed and a wind vane gives the direction from which the wind comes from. Figure 3 gives the anemometer and wind vane used for measuring the wind direction.



## Clouds:



Typically, temperature decreases with altitude, so the lighter stuff (warmer air) is below the heavier stuff (colder air). This typically supports some overturning, especially in the boundary layer. This in turn generates clouds.

Clouds are very common, with 50% of the earth covered in cloud at any given time. Only 1 to 2 % of the clouds are raining. Clouds are classified by height and nature.

(Figure): Cumulus – cauliflower type appearance

Stratus - flat, grey and dull

Cirrus - thin, wispy strands

If a cloud produces rain, then prefix 'nimbo' is added or a suffix numus is added. e.g: nimbostratus, cumulonimbus ... etc Medium level clouds have a prefix 'alto' added. e.g: altocumulus, altostratus ... etc

There are two important weather events in India. They are the monsoons (southwest monsoon and northeast monsoon) and cyclones.

The monsoon rainfall contributes about 75-80% of the mean annual rainfall of the Indian subcontinent. The significant features are large variability of monsoon rainfall over the Indian subcontinent from Rajasthan to Meghalaya where the rainfall varies from 10 cm during a season over Rajasthan to about 1000 cm over places such as Cherrapunji etc.

## Project Examples

Making simple measuring devices and using and validating them

- Calendar - onset of major events such as monsoons
- Making a Rain Gauge ; Human hair hygrometer

## Making a Rain gauge

<http://www.wikihow.com/Build-a-Rain-Gauge>

If you'd like to keep track of how much rainfall you're getting, you can buy a rain gauge, or you can make one out of inexpensive items from your local hardware store. These instructions discuss how to put one together and calculate exactly how much rain has fallen. It's not only easier on the wallet, but it's also a great science project and learning experience for kids.

### Method 1 of 2: Turning a funnel and container into a rain gauge

1. **Assemble the gauge.** Put the funnel securely into a container that's large enough to collect the amount of rain you would normally get in your area without overflowing.

### 2. Work out the surface area of the funnel that you will be using.

- Measure the widest inside diameter of the funnel in cm, divide that by 2 (to get the radius).
- Square that number (multiply it by itself) then multiply by 3.142 to get the area of the top of the funnel.
- Multiply (cm) by 10 (to get mm). This gives you the number to divide by when you are working out how much rain has fallen in millimetres. (Ex: If the area of the funnel (step 2) is 78.55cm<sup>2</sup> (10 cm diameter) and your container filled with 50 ml of rain, then you divide 50 by 78.55 and multiply by 10 to get 6.365mm of rain. (50ml/78.55cm<sup>2</sup>X10=6.365mm)

Using a measuring jug or any other container calibrated in milliliters (ml) measure the amount of rainwater you have collected. Then divide that number by the number you came up in step 2. This gives you the amount of rain in millimeters that has fallen.

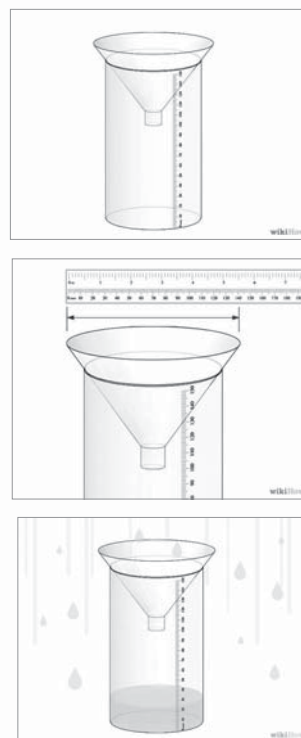

Courtesy: wikihow. <http://www.wikihow/>

## Human Hair Hygrometer

Property used : Length of a human hair is dependent on the relative humidity and it is close to linear

Process: Obtain a reasonably long human hair [or horse hair]. Fix one end to a split cork or some such fixing device. Wind the other end over a wheel that can spin freely. Weigh the wheel with a small weight on the other side so that the wheel is in equilibrium between the tension in the hair and the string. Affix a light pointer to the wheel and place a dial.

Calibration : Put the apparatus in a "dry" environment –dry environment obtained by passing air over desiccators. Mark "0" for the pointer's position. Put near a boiling kettle so that saturated environment is available. Mark "100" for the pointer's position. You have the human hair hygrometer

(Also see <http://www.scientificamerican.com/article/bring-science-home-hair-hygrometer/>)

**Measuring wind speed and direction**

- How to measure speed?
- Why is direction important?
- Wind rose

**Procedure:**

Construct a fan from paper fan-wheel which can rotate freely. Hold the fan against the wind and measure its speed of rotation. [This can be done either by a commercial speedometer or by constructing a strobe light arrangement]. Orient the fan so that the speed is maximum. Note the direction.

**Measuring temperatures**

- Maximum, minimum and average temperature
- Shade or open?
- What is the “hottest month”?

Use a thermometer to measure the temperature every hour in a shaded place. Note it. From the data decide what the maximum and minimum temperature are in a day. Do this for every day for a year to get monthly maximum, minimum and average temperature.

**Potential Projects:**

1. Measure weather parameters and study the impact on something of importance to us.
  - a. Correlate temperature readings with electricity bills.
  - b. Study rain and flower prices .
  - c. Study seasonal variations and illnesses, expenditure on health etc.
  - d. Study rainfall and mosquitoes .
  - e. Study the movement of ants and incidence of rain : Does ants’ movement lead to rainfall prediction?

Remember that for any project in NCSC, experimentation is must and experimenting and observing weather parameters thus makes a mandatory component of all NCSC projects which ever sub theme is selected.

**Impact of any one parameter measured on something of importance to us**

- e.g. Correlate (i.e. draw a graph) on temperature and electricity bills
- Rain and flower prices; seasons & illnesses; rain & mosquitoes
- Ants & prediction of rain

## Glossary

**Air pressure** The cumulative force exerted on any surface by the molecules composing air.

**Alto cumulus** A middle cloud, usually white or gray. Often occurs in layers or patches with wavy, rounded masses or rolls.

**Altostratus** A middle cloud composed of gray or bluish sheets or layers of uniform appearance. In the thinner regions, the sun or moon usually appears dimly visible.

**Anemometer** An instrument designed to measure wind speed.

**Aneroid barometer** An instrument designed to measure atmospheric pressure. It contains no liquid.

**Barograph** A recording instrument that provides a continuous trace of air pressure variation with time.

**Barometer** An instrument that measures atmospheric pressure. The two most common barometers are the mercury barometer and the aneroid barometer.

**Blizzard** A severe weather condition characterized by low temperatures and strong winds (greater than 32 mi/hr) bearing a great amount of snow. When these conditions continue after the falling snow has ended, it is termed a ground blizzard.

**Ceilometer** An instrument that automatically records cloud height.

**Climate** The accumulation of daily and seasonal weather events over a long period of time. A description of aggregate weather conditions; the sum of all statistical weather information that helps describe a place or region.

**Cloud base** The lowest portion of a cloud.

**Cloud cover** The amount of the sky obscured by clouds when observed at a particular location.

**Cumulonimbus** An exceptionally dense and vertically developed cloud, often with a top in the shape of an anvil. The cloud is frequently accompanied by heavy showers, lightning, thunder, and sometimes hail. It is also known as a thunderstorm cloud.

**Cumulus** A cloud in the form of individual, detached domes or towers that are usually dense and well defined. It has a flat base with a bulging upper part that often resembles cauliflower. Cumulus clouds of fair weather are called cumulus humilis. Those that exhibit much vertical growth are called cumulus congestus or towering cumulus.

**Daily range of temperature** The difference between the maximum and minimum temperatures for any given day.

**Desert** One of two types of dry climate—the driest of the dry climates.

**Dew** Water that has condensed onto objects near the ground when their temperatures have fallen below the dew point of the surface air.

**Drizzle** Small drops between 0.2 and 0.5 mm in diameter that fall slowly and reduce visibility more than light rain

**Evaporation** The process by which a liquid changes into a gas.

**Fog** A cloud with its base at the earth's surface. It reduces visibility to below 1 km.

**Hail** Solid precipitation in the form of chunks or balls of ice with diameters greater than 5 mm. The stones fall from cumulonimbus clouds.

**Hailstones** Transparent or partially opaque particles of ice that range in size from that of a pea to that of golf balls.

**Hurricane** A severe tropical cyclone having winds in excess of 64 knots (74 mi/hr).

**Hygrometer** An instrument designed to measure the air's water vapor content. The sensing part of the instrument can be hair (hair hygrometer), a plate coated with carbon (electrical hygrometer), or an infrared sensor (infrared hygrometer).

**Inversion** An increase in air temperature with height.

**Isobar** A line connecting points of equal pressure

**Isotach** A line connecting points of equal wind speed.

**Isotherm** A line connecting points of equal wind temperature.

**Lightning** A visible electrical discharge produced by thunderstorms.

**Meteorology** The study of the atmosphere and atmospheric phenomena as well as the atmosphere's interaction with the earth's surface, oceans, and life in general.

**Mist** Very thin fog in which visibility is greater than 1.0 km (0.62 mi).

**Nimbostratus** A dark, gray cloud characterized by more or less continuously falling precipitation. It is not accompanied by lightning, thunder, or hail.

**Precipitation** Any form of water particles—liquid or solid—that falls from the atmosphere and reaches the ground.

**Psychrometer** An instrument used to measure the water vapor content of the air. It consists of two thermometers (dry bulb and wet bulb). After whirling the instrument, the dew point and relative humidity can be obtained with the aid of tables.

**Rain** Precipitation in the form of liquid water drops that have diameters greater than that of drizzle.

**Rain gage** A device-usually a cylindrical container-for measuring rain-fall.

**Sea breeze** A coastal local wind that blows from the ocean onto the land. The leading edge of the breeze is termed a sea breeze front.

**Sea level pressure** The atmospheric pressure at mean sea level.

**Shower** Intermittent precipitation from a cumuliform cloud, usually of short duration but often heavy.

**Sleet** A type of precipitation consisting of transparent pellets of ice 5 mm or less in diameter. Same as ice pellets.

**Smog** Originally smog meant a mixture of smoke and fog. Today, smog means air that has restricted visibility due to pollution, or pollution formed in the presence of sunlight-photochemical smog.

**Snow** Solid precipitation in the form of minute ice flakes that occur below 0°C.

**Snowflake** An aggregate of ice crystals that falls from a cloud

**Stratocumulus** A low cloud, predominantly stratiform with low, lumpy, rounded masses, often with blue sky between them.

**Stratus** A low, gray cloud layer with a rather uniform base whose precipitation is most commonly drizzle.

**Temperature** The degree of hotness or coldness of a substance as measured by a thermometer. It is also a measure of the average speed or kinetic energy of the atoms and molecules in a substance.

**Thermograph** A recording instrument that gives a continuous trace of temperature with time.

**Thermometer** An instrument used to measure temperature.

**Thunder** The sound due to rapidly expanding gases along the channel of a lightning discharge.

**Tipping bucket rain gage** A device that accumulates rainfall in increments of 0.01 in. by containers that alternately fill and empty (tip).

**Tornado** An intense, rotating column of air that protrudes from a cumulonimbus cloud in the shape of a funnel or a rope and touches the ground. (See Funnel cloud.)

**Trade winds** The winds that occupy most of the tropics and blow from the subtropical highs to the equatorial low.

**Weather** The state of the atmosphere in terms of such variables as temperature, cloudiness, precipitation, and radiation.

**Wind Vane** An instrument used to determine wind direction.

### References:

1. C. Donald Ahrens, 1985. Meteorology Today. West Publishing Company, 497-509.
2. Frederick K. Lutgens, and Edward J. Tarbuck, 1995. The Atmosphere. Prentice-Hall Inc., 443-456.
3. Joe R. Eagleman, 1980. Meteorology The Atmosphere in Action. Litton Educational Publishing Inc., 353-364.
4. Joseph M. Moran, and Michael D. Morgan, 1986. Meteorology. Burgess Publishing, 486-496.

### Some websites where you can get Ocean and Atmosphere related phenomena :

1. National Institute of Oceanography: [www.nio.org](http://www.nio.org)
2. India Meteorological Department [www.imd.gov.in](http://www.imd.gov.in)
3. Indian Institute of Tropical Meteorology [www.tropmet.res.in](http://www.tropmet.res.in)
4. Climate CHIP: <http://www.climatechip.org>

### Some Books on Monsoons

- a. Southwest Monsoon – Y.P. Rao
- b. The Monsoons – P.K. Das
- c. Monsoon Dynamics – T.N. Krishnamurti
- d. Monsoon Meteorology – C.S. Ramage
- e. Monographs of India Meteorological Department, New Delhi available from their website as e copies..





*Sub Theme 2*

**IMPACT OF  
HUMAN ACTIVITIES  
ON WEATHER & CLIMATE**



# Impact of Human Activities on Weather and Climate

## Background

It took about 60000 years for the human population to grow to one billion. It took a little more than two centuries only to grow from one billion to eight billion. Growing population requires environmental resources (life support systems like air, water and soil) for its survival and sustenance. In addition to this, humans, particularly in the developed countries used technology and natural resources to produce and consume goods in large quantities. Hence, pressure on environmental resources has grown manifold during the last two centuries. This pressure has also impacted the climate as well as weather conditions. Whenever we undertake any activity, we always utilise energy in some form or other. As a result the carbon stored in the energy source is released to the atmosphere in the form of carbon dioxide. That indicates our carbon footprint. The more severe is the footprint, the more impact will be there on weather and climate, since carbon dioxide is a greenhouse gas and its accumulation in the atmosphere causes global warming. Direct and indirect impacts of such activities listed below have resulted in change of weather and climate locally and globally.

1. **Agriculture:** The practices were at the expense of forest lands and other ecosystems. Chemical fertilizers, pesticides, irrigation, soil salinity, ground water contamination, methane generation NOx generation etc. impacted weather and climate in one or the other way.
2. **Animal husbandry:** Demand for meat, dairy products, manure, draught animals and easy transport led to animal rearing in large scale resulting in soil compaction, over grazing energy wastage, methane generation, deforestation and water depletion.
3. **Fisheries:** Fertilizing the natural water bodies, eutrophication and ground water contamination results in generation of greenhouse gases.
4. **Human settlement and Urbanization:** deforestation, conversion of agricultural lands to urban areas, more utilisation of energy, infrared radiation, depletion of natural resources etc created heat islands adding to the already aggravating global warming problems.
5. **Industrialisation:** the fast changing scenario in natural resource utilisation and industrialisation in the 19<sup>th</sup> century resulted in rampant deforestation, further conversion of agricultural lands, increased mining, quarrying, energy utilisation, heat islands, industrial effluents, solid waste generation, air and water pollution.
6. **Transportation:** The development of transportation facilities vehicle explosion cause increased fossil fuel utilisation, land use changes, heat generation and air pollution
7. **Communication (paper and electronic):** the communication revolution in the 20<sup>th</sup> century increased the demand for paper and other resources in a tremendous proportion. This led to changes in land use pattern, energy utilisation, depletion of water and deforestation.
8. **Energy production:** The progress of modernisation resulted in more energy input in all the realms of

development. Energy from hydel, thermal and nuclear sources led to greater ecological imbalance on land, water and atmosphere directly or indirectly impacting on weather and climate. Increase in GHG, deforestation, mining generating heat, increased water consumption, dumping of fly ash etc had direct impact. Even certain sectors of renewable sources of energy like wind and solar had its impact on ecosystems.

9. **Waste generation:** the life style changes and throw away culture led to generating huge quantity of municipal, biomedical, industrial and agricultural waste which is cumbersome for nature to take care in its course. The GHG, open burning, dumping yards and burning of rubber, plastic etc added more problems.
10. **Tourism and entertainment:** globalisation, increased transport and communication facilities enhanced a sudden disproportional growth in the tourism industry during the last few decades. This resulted in demand for huge quantity of energy and infrastructure facility which resulted in to large scale land and water encroachment, waste generation etc especially in the developing countries which contributed to the aggravating changes in the ecosystem.
11. **Forestry:** Due to increased demand for preferred type of timber and wood, for the last few centuries trees have been felled from natural forests. The land is utilised for non forestry purpose and at times the land is also utilised for reforestation. However the species diversity gets altered on account of preference of certain selected species like sal, eucalyptus, teak etc. As a result the ecological benefits of natural forests is lost. The relative humidity, temperature water percolation and soil profile etc are changed. Also the carbon sequestration pattern and the rate of biogeochemical cycles changed.

### **Carbon footprint:**

([http://en.wikipedia.org/wiki/Carbon\\_footprint](http://en.wikipedia.org/wiki/Carbon_footprint))

A **carbon footprint** is historically defined as “the total sets of greenhouse gas emissions caused by an organization, event, product or person.”

The total carbon footprint cannot be calculated because of the large amount of data required and the fact that carbon dioxide can be produced by natural occurrences. It is for this reason that Wright, Kemp, and Williams, writing in the journal Carbon Management, have suggested a more practicable definition:

A measure of the total amount of carbon dioxide (CO<sub>2</sub>) and methane (CH<sub>4</sub>) emissions of a defined population, system or activity, considering all relevant sources, sinks and storage within the spatial and temporal boundary of the population, system or activity of interest. Calculated as carbon dioxide equivalent (CO<sub>2</sub>e) using the relevant 100-year global warming potential (GWP100).

Greenhouse gases (GHGs) can be emitted through transport, land clearance, and the production and consumption of food, fuels, manufactured goods, materials, wood, roads, buildings, and services. For simplicity of reporting, it is often expressed in terms of the amount of carbon dioxide, or its equivalent of other GHGs, etc.

Most of the carbon footprint emissions for the average U.S. household come from “indirect” sources, i.e. fuel burned to produce goods far away from the final consumer. These are distinguished from emissions which come from burning fuel directly in one’s car or stove, commonly referred to as “direct” sources of the consumer’s carbon footprint.

The concept name of the carbon footprint originates from ecological footprint, discussion, which was developed by Rees and Wackernagel in the 1990s which estimates the number of “earths” that would theoretically be required if everyone on the planet consumed resources at the same level as the person calculating their ecological footprint. However, given that ecological footprints are a measure of failure, Anindita Mitra (CREA, Seattle) chose the more easily calculated “carbon footprint” to easily measure use of carbon, as an indicator of unsustainable energy use. In 2007, carbon footprints was used as a measure of carbon emissions to develop the energy plan for City of Lynnwood, Washington. Carbon footprints are much more specific than ecological footprints since they measure direct emissions of gases that cause climate change into the atmosphere.

**What is to be understood:**

The children should be able to understand the direct as well as indirect impacts of human activities on weather and climate. The impacts may be in the form of temperature change, change in humidity, changes in water availability, changes in energy level received from sun etc.

**Why it is important:**

Following can be used to introduce climate change to older children. Courtesy Environmental Protection Agency, USA. From A Student's Guide to Climate Change. See

<http://www.epa.gov/climatechange/kids/index.html>

The children should know that human activities are impacting weather and climate in different ways. Some of the impacts may threaten the survival of human race itself. Even if it does not happen so, food shortage, water shortage, temperature variation, flooding, drought, sea level rise, cyclones etc may cause serious implications in terms of economy and well being.

**Is climate change the same thing as global warming?**

No. "Global warming" refers to an increase in the average temperature near the Earth's surface. "Climate change" refers to the broader set of changes that go along with global warming, including changes in weather patterns, the oceans, ice and snow, and ecosystems. Most experts now use the term "climate change" because it gives a more complete picture of the changes that are happening around the world.

**Why is climate change happening?**

The main reason the climate is changing is because people are adding greenhouse gases to the atmosphere. The most important greenhouse gas is carbon dioxide, which is released whenever people burn fossil fuels to do everyday activities like driving cars, heating buildings, and making electricity. As greenhouse gases build up in the atmosphere, they cause the Earth to trap extra heat, making the planet warmer.

**The Earth's Climate in the Past**

The Earth was formed about 4.5 billion years ago—that's a very long time ago! It's hard to say exactly what the Earth's daily weather was like in any particular place on any particular day thousands or millions of years ago. But we know a lot about what the Earth's *climate* was like way back then because of clues that remain in rocks, ice, trees, corals, and fossils.

These clues tell us that the Earth's climate has changed many times before. There have been times when most of the planet was covered in ice, and there have also been much warmer periods. Over at least the last 650,000 years, temperatures and carbon dioxide levels in the atmosphere have increased and decreased in a cyclical pattern. People didn't cause the climate change that occurred thousands or millions of years ago, so it must have happened for other natural reasons.

**Some natural factors that have changed the Earth's climate in the past.**

Changes in the Earth's orbit <http://www.epa.gov/climatechange/kids/basics/past.html>

Changes in the sun's energy <http://www.epa.gov/climatechange/kids/basics/past.html>

Photosynthesis <http://www.epa.gov/climatechange/kids/basics/past.html>

Volcanic eruptions <http://www.epa.gov/climatechange/kids/basics/past.html>

What are the most visible signs of climate change?

You can't see the signs of climate change from one day to the next, but if you compare from year to year, the clues are everywhere! For example, as the Earth has become warmer, the average sea level around the world has risen by nearly 7 inches in the last 100 years, glaciers all over the world are shrinking, and many bird species are shifting northward. Some of the most obvious changes are happening in the Arctic, where the amount of ice in the ocean has decreased dramatically.

Can climate change harm plants and animals?

Yes. Any change in the climate of an area can affect the plants and animals that live there. Some animals might adapt or move elsewhere, but others could have trouble surviving. For example, if the ice in the Arctic Ocean disappears, the animals that depend on this ice won't have anywhere else to go. Climate change also alters plants' and animals' life cycles. For example, some flowers are blooming earlier in the spring, while some animals are migrating at different times.

### **The Earth's climate is changing, and people's activities are the main cause.**

Scientists around the world agree that today's global climate change is mainly caused by people's activities.

### **Today's Climate Change Is Different!**

Today's climate change is different from past climate change in several important ways:

- 1. Natural causes are not responsible.** None of the natural causes of climate change, including variations in the sun's energy and the Earth's orbit, can fully explain the climate changes we are seeing today.
- 2. People's activities are the main cause.** By burning lots of fossil fuels like coal, oil, and natural gas, people are overloading the atmosphere with carbon dioxide and adding to the greenhouse effect. People are also adding other heat-trapping greenhouse gases, such as methane and nitrous oxide, to the atmosphere.
- 3. Greenhouse gases are at record levels in the atmosphere.** For hundreds of thousands of years, the concentration of carbon dioxide in the atmosphere stayed between 200 and 300 parts per million. Today, it's up to nearly 400 parts per million, and the amount is still rising. Along with other greenhouse gases, this extra carbon dioxide is trapping heat and causing the climate to change.

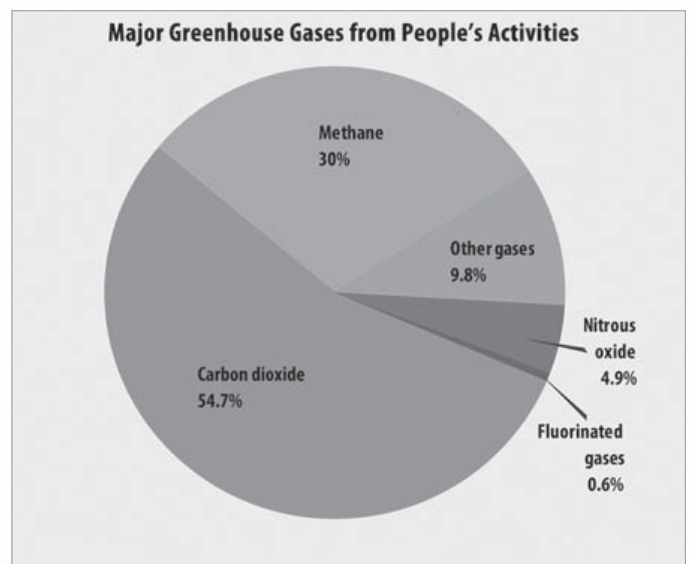

Source: EPA's *Climate Change Indicators* (2010).

The size of each piece of the pie represents the amount of warming that each gas is currently causing in the atmosphere as a result of emissions from people's activities.

The Earth's climate is getting warmer, and the signs are everywhere. Rain patterns are changing, sea level is

rising, and snow and ice are melting sooner in the spring. As global temperatures continue to rise, we'll see more changes in our climate and our environment. These changes will affect people, animals, and ecosystems in many ways.

Less rain can mean less water for some places, while too much rain can cause terrible flooding. More hot days can dry up crops and make people and animals sick. In some places, people will struggle to cope with a changing environment. In other places, people may be able to successfully prepare for these changes. The negative impacts of global climate change will be less severe overall if people reduce the amount of greenhouse gases we're putting into the atmosphere and worse if we continue producing these gases at current or faster rates.

***People are adding carbon dioxide to the atmosphere faster than it can be removed.***

*Scorching summers... Melting glaciers... Stronger storms...*

*The signs of global climate change are all around us.*

*Source: NASA/courtesy of nasaimages.org.*

## **What You Can Do**

Can one person help stop global climate change? Yes! Especially when the simple steps you, your friends, and your family take are multiplied by millions of people all over the world.

### **Switch to Clean Energy**

When we get electricity from renewable energy sources like wind and solar power, we avoid the carbon dioxide emissions that would have come from burning fossil fuels like coal, oil, or natural gas.

- **Choose green power.** Talk with your family and school about switching to renewable energy.
- **Generate your own power.** Can your school or home generate its own renewable energy? Talk with your family and school about the possibility of installing solar panels, a solar water heater, or even a wind turbine.

### **Use Less Energy**

Most of the energy you use at home and at school comes from burning fossil fuels. Using less energy means burning fewer fossil fuels and putting less carbon dioxide into the atmosphere.

### **Watch Your Water Use**

Saving water saves energy, which in turn reduces greenhouse gas emissions. It takes a lot of energy to treat the water you use every day to make it safe to drink and to deliver it to your house. It takes even more energy to turn it into hot water. Did you know that letting your faucet run warm water for five minutes uses about as much energy as leaving a 60-watt light bulb on for 14 hours?

### **Reduce Waste**

Most people don't realize that reducing, reusing, and recycling can help slow climate change. How? To begin with, every product has a life cycle, and every step—from manufacturing to disposal—leads to greenhouse gas emissions. Reducing, reusing, and recycling means you buy (and throw away) less stuff, and that helps reduce the amount of greenhouse gases we're adding to the atmosphere.

### **You can reduce greenhouse gas emissions if you:**

- **Reduce.** Reduce the amount of new stuff you buy. To reduce waste, buy things that have less packaging.
- **Reuse.** Try to borrow or rent things you'll only need for a short amount of time, and reuse the things you already have. When you have things you no longer need, give them to others who can use them. Use reusable bags when you go shopping.
- **Recycle.** Remember to recycle whatever materials you can, like bottles, cans, and paper, so they can be collected and remade into new products.
- **Buy recycled.** Choose products made from recycled materials whenever you can.
- **Teach your school the three R's.** Schools can save energy, preserve natural resources, and prevent greenhouse gas emissions by reducing, reusing, and recycling.

### **More Ways to Make a Difference**

You can take many other actions to help reduce greenhouse gas emissions and global climate change. For example:

- **Plant a tree.** Trees help to slow climate change because they absorb carbon dioxide during photosynthesis. Trees also provide shade, which helps keep streets and houses cooler in the summertime and reduces the need for air conditioning.
- **Consider buying locally grown food.** The further your food travels, the more greenhouse gas emissions are produced in transporting the food from the farm to your plate. You can find locally grown food at a farmers market and even at some grocery stores.
- **Reduce your carbon footprint.** Find out how big your own carbon footprint is, and explore ways you can reduce it.
- **Spread the word.** Give a presentation to your family, school, or community group that explains how their actions can cause or reduce climate change. You can develop your own. Get creative, and think of more ways to help others make a difference!

### **How to go for it:**

The children through their observations studies, projects, etc, will be able to understand the concept of weather and climate and their relationship with human activities. In future if they get opportunities they may be intellectually prepared to improve human activities in such away that weather and climate are impacted least.

### **An example of human impact on local climate**

Anamalais is the Hill Range in the southern Western Ghats, immediately south to Palakkad Gap. The highest peak in the Western Ghats, Anamudi which stands at 2695 m above the sea level is in the Munnar region in the Anamalais. Further south to the Anamalais is the High Ranges which is a plateau with heavy rainfall and with undulating terrain. The area forms the catchment of Periyar, a major river originating from the Southern Western Ghats. The area was once covered with dense evergreen forests, stunted shola forests and high altitude grasslands. The British during the colonial time discovered that this region would be ideal for some kind of plantations. Large stretches of forests in the Munnar region were cleared for raising tea plantations in the 1880s. The forests of High Ranges were opened up to cultivate cardamom in 1890s. The human population grew up in this region gradually and the



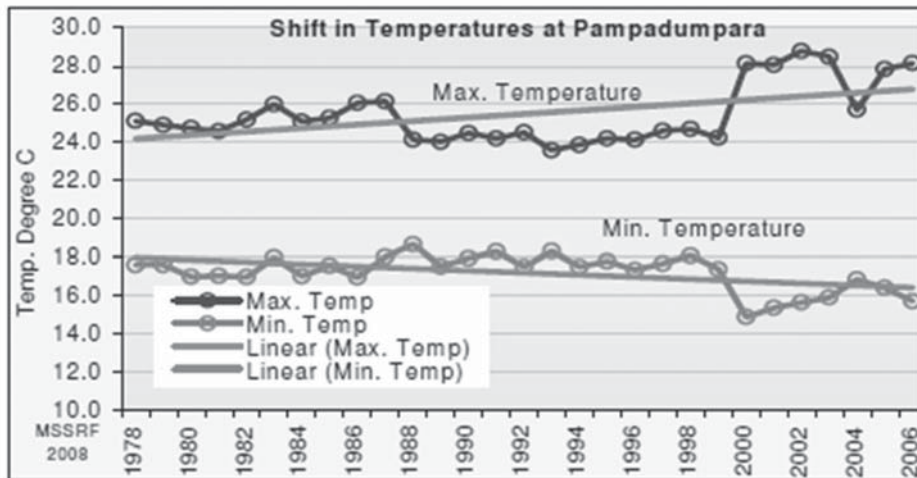

human activities and the so called developmental activities resulted in dwindling of the forest cover in the region. Many small and large urban centers were emerged with the increase of population and increased transportation facilities causing further loss of forests. The analysis of weather data being recorded for the last more than 100 years has clearly shown a change in climate in Munnar and High Ranges during this period. The temperature data from Pampadumpara in the High Ranges showed a shift in the maximum and minimum temperature during the last 30 years. As per the data available from Munnar, there is a decreasing trend in the total rainfall and number of rainy days during the last more than 70 years. These changes are supposed to be because of the impacts of human activities in the region during last more than 100 years.

(Source of the pictures: Measures to mitigate agrarian distress in Idukki district of Kerala: M. S. Swaminathan Research Foundation, 2008.)

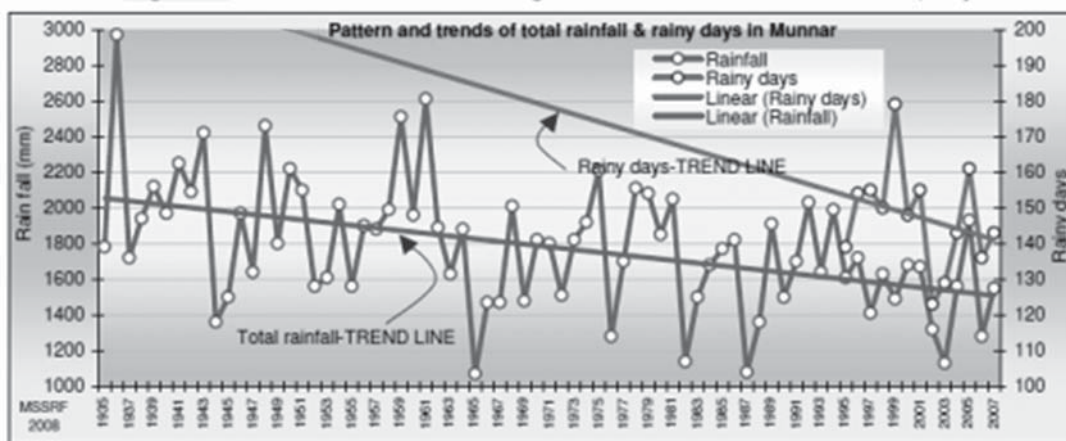

### Climate Change and Increasing Disasters in India

These short term climate fluctuations and extreme weather events have been the most frequently occurring hazards and in combination with social vulnerability have been responsible for the vast majority of disaster losses worldwide. Centre for Research on Epidemiology of Diseases (CRED) categorizes these disasters resulting from climatic variability and other climatic and meteorological causes as hydro-meteorological disasters (floods, landslides,

mudflows, avalanches, tidal waves, windstorms, including typhoons, cyclones, hurricanes, storms, winter storms, tropical storms and tornadoes, droughts, extreme temperatures, and complex disasters associated with drought) as distinct from geological disasters (earthquakes, volcanic eruptions and tsunamis). The hydro-meteorological disasters resulting from climate variability and other climatic and meteorological causes are also commonly referred as 'climate disasters' in disaster studies. Climate disasters have always been a recurring theme in human history, and are on rising trend.

A number of experts link the current trends in extreme weather events with the increase in the global mean temperature. The CRED report states that there 'there is increasingly conclusive evidence which confirms that global climate change will have an impact on the occurrence and magnitude of extreme events. These impacts are envisaged to increase human vulnerability to natural disasters, thus emphasizing the need for improved measures of preparedness in every part of the world'. The report also surmises that the current trends are consistent with the predictions in the case of Asia, and West Africa that are already suffering from more severe and frequent floods. Many future projections by Intergovernmental Panel for Climate and Climate change (IPCC) indicate that there is 'increased confidence that some weather events and extremes will become more frequent, more widespread and/or more intense during the 21st century and impacts due to altered frequencies and intensities of extreme weather, climate and sea level events are very likely to change'.

Also, there is evidence now that climate change, with present developmental trends, will not express itself in through slow shifts in average conditions, but will manifest at an unprecedented rate with increased variability, frequency of extreme events, long term implications and possibility of abrupt change, fuelled largely through anthropogenic causes. Under such trajectory these two processes do have the potential to coalesce generating destructive forces which could cause mega disasters unless urgent, radical and resolute mitigation actions are not implemented.

The projected climate change will affect India particularly severely. Its consequences include a rise in sea level, threatening areas such as the densely populated Ganges delta, changes in the monsoon rains, the melting of the glaciers in the Hindukush-Karakorum-Himalaya region (crucial for the water supply in the dry seasons), and the foreseeable increase in heavy rain events and intensity of tropical cyclones. The unprecedented heavy rain on 26<sup>th</sup> July 2005 in **Mumbai** is an example. In a span of 24 hours **Mumbai** recorded more than 90 cm **rainfall**, a rare event in the western coast. Nobody will forget the aftermath of the cloudburst on **16 June** 2013 in the **Uttarakhand** Himalayas and the massive landslides in Kedar and Kumaon regions which killed thousands of people.

The thousands of glaciers located across the 2,400 km of the Himalayan range are at the **epicentre** of an emerging crisis. The effect of possible changes in the intensity of the monsoons will be particularly sensitive, because large parts of India receive the majority of their annual precipitation during the summer monsoon rains, which already vary noticeably in different regions. The summer monsoon is crucial to the annual precipitation total of the Indian subcontinent. Over 40 million hectares (12 % of land), is prone to floods, close to 5700 kms of its 7516 km coast line (about 8%), is cyclone prone and exposed to tsunamis and storm surges, 2% of land is landslide prone, and 68% of India's arable land is affected by droughts. Of the 35 States and Union Territories, as many as 27 are disaster prone. Most disasters in India are water related the east coast of India, which lies in the path of tropical hurricanes from the Gulf of Bengal, is particularly at risk of being damaged by storms and floods.

The projections by the National Institute of Oceanography (NIO), under the Council of Scientific and Industrial Research (CSIR), Government of India on the impacts of climate change on sea level, to assess the degree to which mean sea level and the occurrence of extreme events may change, showed an increased occurrence of cyclones in the Bay of Bengal, particularly in the post-monsoon period, along with increased maximum wind speeds associated with cyclones and a greater number of high surges under climate change. In addition, the strength of tropical cyclones, which represent a threat to the eastern coast of India and to Bangladesh, could increase. The risk to these areas will be aggravated by the rising sea level.

Vast stretches of land in India suffers acute water shortage. Of the net area sown in the country, 68 percent is prone to drought, and of this 33 percent is chronically drought-prone, receiving rainfall of less than 750 mm per annum, while 35 percent receives rainfall between 750-1,125 mm per annum. The steady shrinking of the Himalayan Glacier ranges will drastically cut down water availability in downstream plains of Uttar Pradesh and Bihar. India's initial National Communication to the United Nations Framework Convention (UNFCCC) on Climate Change projects that Luni, the west flowing rivers of Kutchh and Saurashtra occupying about one fourth of the area of Gujarat and 60 % of Rajasthan are likely to experience acute physical water scarcity. The river basins of Mahi, Pennar, Sabarmati and Tapi are also likely to experience constant water scarcities and shortages .

**Landslides** The areas that suffer from landslide hazards are located in the hilly tracts of the Himalayas, Northeast India, Nilgiris, Eastern Ghats and Western Ghats. With the melting of the glaciers in the Hindukush-Karakorum-Himalaya region, and the foreseeable increase in heavy rain events and intensity of tropical cyclones, the incidences of landslides are likely to increase.

**Coastal zone** India has an 8000 km-long coastline with two cyclone seasons, during the southwest and northeast monsoons. Cyclones have been observed to be more frequent in the Bay of Bengal than the Arabian Sea. Future climate change in the coastal zones is likely to be manifested through worsening of some of the existing coastal zonal problems. Some of the main climate related concerns in the context of the Indian coastal zones are erosions, flooding, submergence and deterioration of coastal ecosystems, such as mangroves and salinization. In many case these are caused by, or, exacerbated by, sea level rise and tropical cyclones.

**We are suggesting some project ideas. The children can enrich their concept and knowledge which will help them in framing projects.**

### **Ideas for projects**

1. Long term changes in weather condition of the locality : rainfall(total and pattern), temperature , relative humidity, number of rainy days, wind speed and direction data are to be obtained on long term basis (for more than 30 years) from sources already available and plot the data to indicate any obvious changes in the parameters. If possible discuss and correlate the changes with certain observable parameters in the environment of the area. The changes may be correlated with the impact on agricultural production, drought, flood etc.
2. Urbanisation: Changes in land use in the area due to human habitation and urbanisation: Children will interact with senior persons in their locality to obtain information about changes in land use in the form of conversion of agricultural land, orchards, grassland, wilderness areas in to human habitation. The top sheets

of different periods and google earth images may be used (students should get a chance to know top sheets and other sources of knowledge on earth surface, past and present) They will quantify diversions for various purposes. Compare temperature regime and humidity level in the surrounding area and in the habitation.

3. Analysis of waste generation, collection, and disposal in a locality and its impact on weather and climate: children will sample waste generated in few premises and classify them under biodegradable and non-biodegradable. They will observe the approximate percentage of waste collected by the local authority and their disposal methods. They will make rough estimations of carbon dioxide and methane emissions from the waste. These two gases directly impact the climate and weather, as these are GHGs.
4. Evaporation from man-made reservoirs and its impact on local weather: Children can plan experiments with containers of different diameters. They can put same quantity of water in all the container and leave them. Every second day they can measure the loss of water by measuring the quantity left in each container. They should correlate evaporation rate with diameter of the container which is indicative of exposed surface area. They can correlate the findings with field observations. Ponds, ditches, lakes etc. which are shallow dry up fast as compared to the deeper ones. Water vapour is a greenhouse component and also loss of water will reflect on availability of water in the locality

#### **Resources for use:**

1. Many links explaining weather, climate, climate change and its impacts by The Energy and Resources Institute, New Delhi: <http://know.climateofconcern.org/index.php>
2. A Guidebook on Climate Science by the U.S. Global Change Research Program: [http://downloads.globalchange.gov/Literacy/climate\\_literacy\\_highres\\_english.pdf](http://downloads.globalchange.gov/Literacy/climate_literacy_highres_english.pdf)
3. A Climate Change Communication Toolkit including Carbon Footprint Calculator, Presentations, Posters, Childrens' Activity Booklet and others by the The Mumbai Metropolitan Region – Environment Improvement Society (MMR-EIS): <http://www.mmr-ccrt.org.in/index.php?lang=en>
4. Childrens' Activity Booklet on Climate Change by the The Mumbai Metropolitan Region – Environment Improvement Society (MMR-EIS): [http://www.mmr-ccrt.org.in/images/CCRT\\_ChildrensActivityBooklet\\_draft5a.pdf](http://www.mmr-ccrt.org.in/images/CCRT_ChildrensActivityBooklet_draft5a.pdf)
5. An Indian Guidebook to Low Carbon Lifestyle, giving Carbon Footprint Savings as well as money savings: <http://www.coolcalculator.org/toolkit.pdf>
6. Carbon Footprint Calculator for each region in India hosted by the ICICI Bank: [http://www.icicibank.com/go-green/carbon-world-day/indexef62.html?utm\\_source=go-green-homepage&utm\\_medium=display&utm\\_event=go-green-carbon-footprint-calculator](http://www.icicibank.com/go-green/carbon-world-day/indexef62.html?utm_source=go-green-homepage&utm_medium=display&utm_event=go-green-carbon-footprint-calculator)
7. Provides emission factors for Indian electricity, petrol, diesel and cooking gas: <http://greencleanguide.com/2011/09/14/calculate-your-carbon-footprint/>
8. Carbon Footprint Calculator provided by Tata Power: <http://www.tatapower.com/sustainability/carbon-footprint.aspx>

9. Carbon Footprint Calculator for major cities in India, including food: <http://www.no2co2.in/CarbonCalculator.php>
10. Detailed Emissions Factor Ready Reckoner including food and other usage articles, apart from energy items: [http://www.no2co2.in/admin/utills/internalresource/intresourceupload/EF\\_ready\\_reckoner\\_india\\_Mar2012\\_CC.pdf](http://www.no2co2.in/admin/utills/internalresource/intresourceupload/EF_ready_reckoner_india_Mar2012_CC.pdf)
11. Draft article that has researched the Carbon Footprint of different classes of households in India: [http://www.wiod.org/conferences/groningen/Paper\\_Grunewald\\_et\\_al.pdf](http://www.wiod.org/conferences/groningen/Paper_Grunewald_et_al.pdf)
12. Wikipedia on Carbon Footprint: [http://en.wikipedia.org/wiki/Carbon\\_footprint](http://en.wikipedia.org/wiki/Carbon_footprint)
13. Carbon Footprint Calculator oriented to western countries, by The Nature magazine: <http://www.nature.org/greenliving/carboncalculator/>
14. Provides links on teaching climate concepts and student activities related to that: [http://cleanet.org/clean/literacy/climate\\_lit.html](http://cleanet.org/clean/literacy/climate_lit.html)
15. Provides video links to explain climate change to children: <https://www.oercommons.org/courses/climate-change>
16. Teachers Resource Guide on Climate Change by UNICEF provides many activities for children: <http://teachunicef.org/sites/default/files/documents/climate-change-children-and-youth.pdf>
17. The Human impact of Climate changes in India. Freya Seath, CLRA, Published by VinodBhanu, Executive Director, CLRA, 9 Firoze Shah Road, New Delhi, 001.freya@clraindia.com
18. Links to presentations and materials for kids and teachers on Global Warming: <http://www.freeclubweb.com/powerpoints/science/globalwarming.html>
19. Links to science presentations and games to children on weather and climate: <http://science.pppst.com/index.html>

## Glossary

**Animal husbandry:** is the management and care of farm animals by humans for profit, in which genetic qualities and behaviour, considered to be advantageous to humans, are further developed.

**Biodegradable:**generally organic material such as plant and animal matter and other substances originating from living organisms, or artificial materials that are similar enough to plant and animal matter to be put to use by microorganisms.

**Eutrophication:** The process by which a body of water becomes enriched in dissolved nutrients (as phosphates) that stimulate the growth of aquatic plant life usually resulting in the depletion of dissolved oxygen

**Urbanisation:**is the increasing number of people that migrate from rural to urban areas. It predominantly results in the physical growth of urban areas, be it horizontal or vertical. The United Nations projected that half of the world's population would live in urban areas at the end of 2008. By 2050 it is predicted that 64.1% and 85.9% of the developing and developed world respectively will be urbanized

**Urban heat islands:**An **urban heat island (UHI)** is a metropolitan area that is significantly warmer than its surrounding rural areas due to human activities. The phenomenon was first investigated and described by Luke Howard in the 1810s, although he was not the one to name the phenomenon. The temperature difference usually is larger at night than during the day, and is most apparent when winds are weak.

**Carbon sequestration:**is the process of capture and long-term storage of carbon dioxide or other forms of carbon to either mitigate or defer global warming and avoid dangerous climate change. It has been proposed as a way to slow the atmospheric and marine accumulation of greenhouse gases, which are released by burning fossil fuels. Carbon dioxide is naturally captured from the atmosphere through biological, chemical or physical processes. Planting more trees is one of the methods.

**Biogeochemical cycles: Biogeochemical cycle or substance turnover or cycling of substances** is a pathway by which a chemical substance moves through both biotic (biosphere) and abiotic (lithosphere, atmosphere, and hydrosphere) compartments of Earth. A cycle is a series of change which comes back to the starting point and which can be repeated. Water cycle, carbon cycle, nitrogen cycle etc.

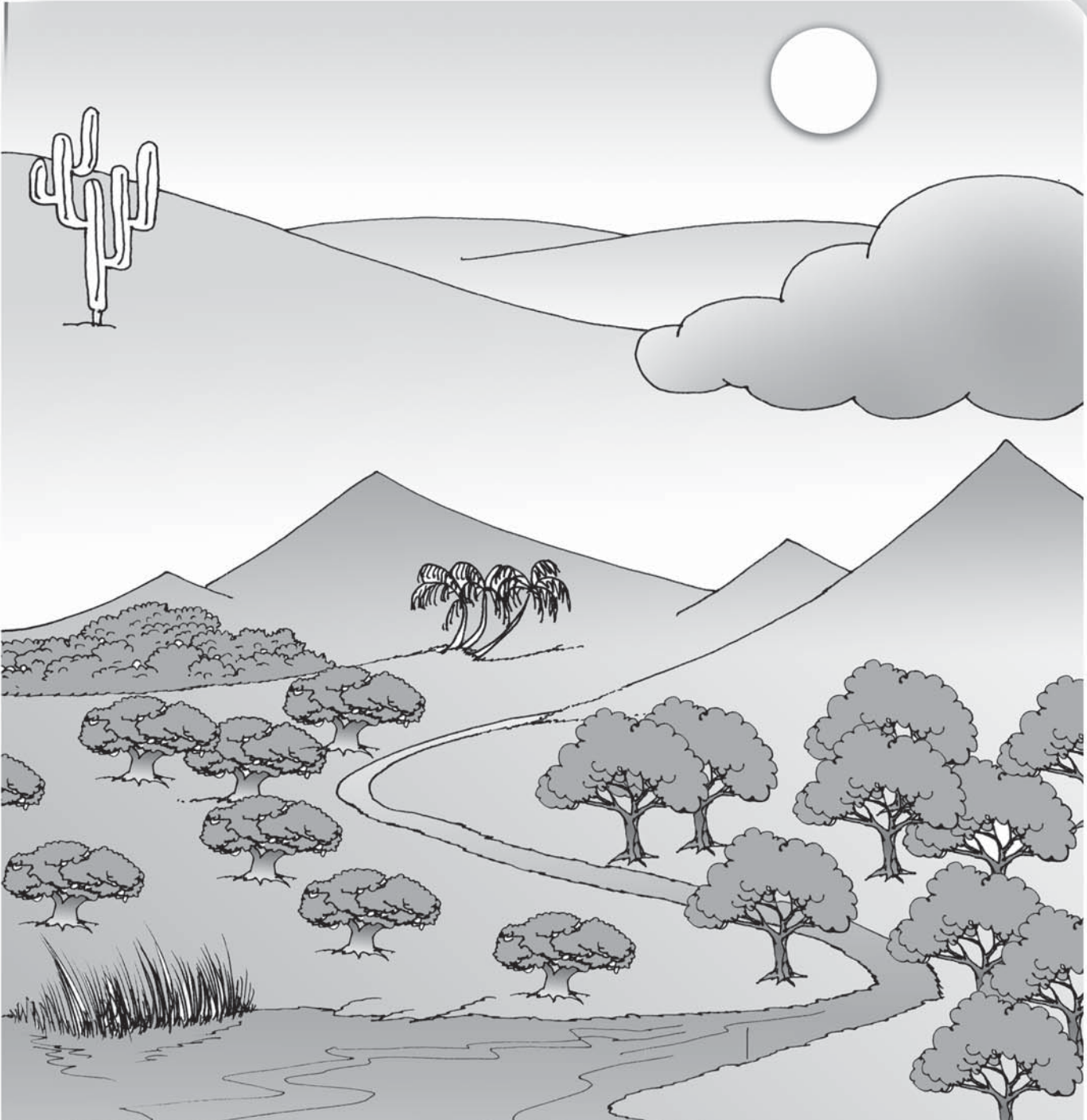

*Sub Theme 3*

**WEATHER, CLIMATE  
& ECO SYSTEMS**





# Weather, Climate and Ecosystems

## Introduction

Weather and climate are important physical environmental factors which influence the ecosystems. The term Ecosystem deals with the biotic (living) and abiotic (nonliving) components within the environment along with the factors interacting each other. An ecosystem can be as large as an ocean or as small as a local pond. Ecosystems provide people with food, goods, medicines, and many other products. They also play a vital role in nutrient cycling, water purification, and climate moderation. All weather and climatic parameters affect the ecosystem elements in various ways. In turn, biotic elements influence the development of microclimate in an ecosystem. Human activities also affect weather and climate which now has come to reality leading us to the perceived global climate change.

Weather and Climate have profound effects on ecosystems and the habitats that support life on earth. The variation of temperature, humidity and precipitation the quality of water, soil forming process directly will influence the floral growth and faunal composition. Even though smaller changes are taking place in weather conditions a fairly high impact may be observed on natural resources. Changes are expected to alter the makeup and functioning of ecosystems, as well as some of the critical benefits that ecosystems provide to people. Fast changes in the climate can threaten ecosystems that have already been weakened by other human activities such as pollution, development, and overharvest etc.

Biodiversity is the living component of any ecosystem. Although species have adapted to environmental change for millions of years, a quickly changing climate could require adaptation on larger and faster scales than in the past. Those species that cannot adapt are at risk of extinction. Even the loss of a single species can have cascading effects because organisms are connected through food webs and other interactions.

The timing of many natural events, such as flower blooms and animal migrations, is linked to climate factors such as temperature, moisture availability, and amount of daylight. Changes in weather patterns and extreme events associated with climate change can disrupt these natural patterns. These disruptions, in turn, can affect seasonal behavior and interactions among species. For example, if birds migrate and lay eggs too early, hatchlings might not have an adequate food supply. While some animals and plants will successfully adjust life-cycle patterns to changing weather pattern cues, others might not be so successful. Climate change can alter where species live and how they interact, which could fundamentally transform current ecosystems. Impacts on one species can ripple through the food web and affect many organisms in an ecosystem.

India's weather and climatic conditions are naturally controlled by its geographical locations and hence the parameters of weather vary from place to place. Due to such variations the vegetation type, soil quality and water quality also vary from place to place.

Weather and Climate variability have various significant parameters such as Rain, Temperature, Wind and Humidity that inflict impact on the abiotic and biotic nature on earth. These parameters have effect on the occurrence, abundance, seasonality and behavior of living organisms as well as quality of air, water and soil. It has direct or indirect effect on the various ecosystems. When some of these ecosystems are available every where in India some will be restricted to very specialized locations.

### Types of ecosystems

#### Terrestrial ecosystems

- Forest ecosystem – Various types of forests across the country
- Agricultural ecosystem – Various crop systems across the country
- Grassland – Secondary, rarely the primary grass lands in many parts of the country
- Desert ecosystem – Eg: Thar desert in Rajasthan
- Hill and mountain ecosystems : Eg: Himalayas, Western & Eastern Ghats, North Eastern Hills, Aravali, Vindya - Satpura etc
- Iceland ecosystems : Himalayas

#### Aquatic ecosystems

- Pond, Lake, River ecosystem Temporary Wetlands : most parts of the country
- Mangroves, Marine, Estuaries and Lagoons: Coastal area

### Logical framework

Weather and climate variability affect the phenology of plants, occurrence of various floral and faunal elements populations of different species and in the manifestation of many behavior of animals. The consequences of climate variability at a macro level could be manifested as disasters also such as floods, droughts, unprecedented rains, inconsistencies in seasonal temperature etc on various ecosystems.

### Flow chart

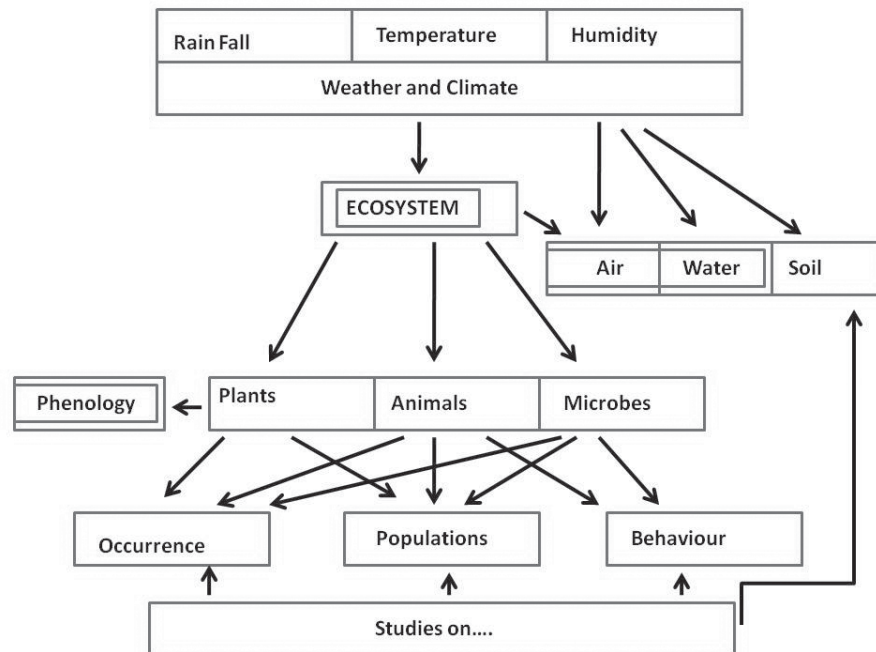

We need to understand and observe the changes in weather parameters as well as the changes in biotic and abiotic parameters around us. This will enable us to study the effect of the weather/climate on ecosystems. For example in pond ecosystem the intensity of rain will change the level of water, change the pH level, turbidity and so on which in turn influence the biological activities such as growth of grass, flowering, population of insects, fishes and birds. They also behave in different ways. Systematic observations, measurement and analysis make us understand the functioning of ecosystem in better way. To understand the effect of weather and climate on the life on the surrounding or vice versa the children's projects should begin with asking significant questions to that effect.

### **Different component and aspects to be covered under this subtheme**

1. The various components contributing to the weather and climate conditions such as temperature, pressure, wind, precipitation and humidity are important for the study depending on the question under study.
2. Biotic components such as flora, fauna and microbes in a given ecosystem
3. Abiotic component such as air, water and soil.

### **Project Examples**

#### **1. Influence of vegetation cover on microclimate**

The microclimate in simple term refers to the modified climate of a small area which can be different in temporal and spatial scale from the climate of the region. The microclimate is modified by vegetation cover, industrialization, development of human settlement and any other intervention in the land use pattern. Tree plantation restricts incoming radiation and has a cooling impact on the microclimate. Trees also act as shelterbelts and reduce desiccating effect of wind. Vegetation cover greatly modifies the soil environment in long run which is a vital component of the microclimate. Modification of microclimate is the perceptible and immediate effect of anthropogenic intervention in land use system. A basic understanding of microclimate will help the students to conceive the possible impact of land use change.

#### **Objective**

- To understand the microclimate of an area
- To study the influence of vegetation cover on microclimate
- To have a comparative study of microclimate under different land use system

The experiment may be divided in two components

- (A) Field study - monitoring microclimate of different land use system
- (B) Development of workable model to understand the concept of microclimate

#### **Part A: Field study - monitoring microclimate of different land use systems**

#### **Methodology**

Select different land use systems in the surrounding locality

- a) Crop land
- b) Barren land
- c) Forest land/Orchard

d) Settlement areas and any other typical land use system.

Two simply measurable parameters: temperature and evaporation are selected. This can be improvised by incorporating additional indicators.

- Keep circular leak proof open pan of ½ m diameter and 50 cm depth at the representative place of each land use system. Fill with water up to 30 cm depth. Cover it with wire net.
- Keep the thermometers in suitable places to measure soil temperature, water temperature (of the pan) and air temperature in these sites. Care should be taken to avoid direct radiation on the bulb of the thermometer.
- Record the temperature observations three times daily at early morning (say, 7 am), mid day (say at 12 to 2 pm) and during evening (say, 6 pm) over a period of 4 months at weekly interval.
- Record the depth of water from these pans at weekly interval and add water as per requirement during the period of study
- Collect the soil samples from each site at 10 cm depth 3 days after each rain event. Take the fresh weight (immediately after collection) and again by drying the same sample at 105 °C for 24 hours in an oven. Calculate the moisture content as below -

$$\text{Soil moisture content} = (\text{Fresh soil weight} - \text{Dry soil weight}) / \text{Dry soil weight}$$

The impact on soil evaporation can only be perceptible if soil types are same because the soil type (textural class) is a major driving factor for water release from soil for evaporation

**Important note:** It is a group activity. Time synchrony has to be maintained for observations at different field sites. Each student may be assigned one site for diurnal observation.

### **Relevance:**

Note the difference in temperature and evaporation rate from each observation site. These parameters are easily perceptible but important indicators to define a microclimate of a place. Mark, how human intervention changes the microclimate. This will give help the students to understand the microclimate and in broad sense demonstrate how anthropogenic intervention is responsible for modification of the climate on the earth surface.

### **Part B: Understanding the concept of microclimatic**

#### **Materials required**

- Earthen pot (6 Nos)
- Seedlings (Fast growing plant depending local suitability)
- Card board & Ply board
- Thermometer (2 Nos)
- Open pan of 20 cm diameter and 5 cm depth

#### **Methodology:**

- Take 6 earthen pots. Make a hole at the bottom of each pot.
- Fill the pots with one thin layer of small stones at the bottom and the rest with soil
- Plant one seedling in each pot and water regularly.

- Make two model houses using card board / ply board
- Place one model house in the middle of 6 pots and one house in open area
- Measure the temperature of the roof top of each house (using thermometer) at 15 days interval starting from the date of planting.
- Place the open pan near each model house and keep 2 cm depth of water in each pan. Add water to each pan after drying.
- Note the temperature difference between the two situations
- Note the time required to dry up the water from each pan

### **Relevance:**

This project will give a direct experience to the students about how plantation helps in ameliorating the microclimate. Maintaining the plants from sowing to subsequent growth will induce the association of students with the plants and will help in understanding the concept of microclimatic modification at the same time. Hands-on learning process will be an interesting and effective method.

Note: These two exercises (part-A & part-B) may be considered complimentary to each other

## **2. Effect of weather on soil fauna**

### **Introduction:**

Soil is one of the most diverse habitats on earth and contains one of the numerous assemblages of living organisms. Soil biota includes bacteria, fungi, protozoa, nematodes, mites, collembolans (springtails), annelids (earthworms), macro arthropods (insects, woodlice) etc. The primary role of soil biota is to recycle organic matter that is derived from the above ground plant based food web. Weather has a profound effect on soil fauna.

### **Objectives:**

1. To observe and document some visible life forms present in the land.
2. To record the seasonal variation and the type of biodiversity present in the soils of varying productivity levels.
3. To study effect of rainfall and soil temperature on soil fauna

### **Methodology:**

#### **Sampling of soil and soil fauna:**

Sample should be taken from the root zone of plants. Collect soil samples with specific quadrat. Take sample from different locations within the area and mix together. Collect the soil and place it in a ziploc bag. It should not be touched with hands. Separate soil samples will be collected for some physico-chemical analysis viz. texture (feel method), colour, pH etc.

#### **To study the organisms in the soil:**

1. Larger animals can be easily separated (Earthworms, beetles, etc)
2. To catch small arthropods, take a Tullgren funnel. Set a piece of ¼ inch rigid wire screen in the bottom of the

funnel to support the soil. Half fill the funnel with soil, and suspend it over a cup with a bit of anti freeze or ethyl alcohol in the bottom as a preservative. Suspend a light bulb (25 W) for about 4-5 days over the soil to drive the organisms out of the soil. Animals will move away from the light and heat and fall down in the cup placed below.

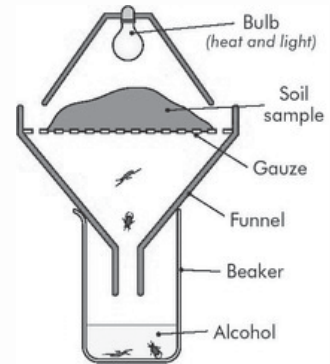

**Observation:**

- Date
- Time:
- Weather: Sunny/ Rainy /Cloudy etc.
- Sampling area:
- Characteristics of the soil:
- Sample size:

Sample no.	Type of organism	No. of individual	Remarks

Performing this study a student can realize the possibility of using the soils in industry and how quality of raw materials influence end product quality. The magnitude of large scale destruction of good quality of soil through other purposes can also be assessed.

**Analysis:**

1. Appropriate data sheet may be created for soil fauna.
2. Abundance of different species or relative density could be analyzed from the data collected using following formula.

3. Abundance = 
$$\frac{\text{Total no. of individuals of the species in all the sampling units}}{\text{No. of sampling units in which the species occurred}} \times \frac{\text{Total no. of individual species}}{\text{Total no. of individual in all species.}}$$

4. Relative density = 
$$\frac{\text{Total no. of individual species}}{\text{Total no. of individual in all species.}} \times 100$$

5. Seasonal variation of the animals could be noted under different soil conditions.

**Conclusion:**

1. Significance of habitat choice by the organism can be studied.
2. Dominant species and rare species can be shown.
3. Compare the result between or among the soils.

**Relevance of the project:**

A comparison of soil macro fauna in different types of soil like, forest, agricultural land, and urban, eroded, etc can be shown. The analysis of results may suggest remedies for eco-restoration of the degraded land.

### 3. Effect of rainfall on phenology of plants

#### Objectives:

1. To study the phenology of plants in relation to the rainfall in an area.
2. To analyse the relation between temperature/rainfall and various pheno-phases of plants

#### Methodology

- Select a set of common plants species available in your locality.
- Then collect information about these species from elderly people and observation about their period of flowering, fruiting and other characteristics
- Start observations on each of these plants and record the phenology (budding, leaf flushing, flowering, fruiting, seed dispersal etc) of the plant systematically
- The data gathered thus should be tabulated analysed and compared to understanding the change in phenology of the different species.

#### Observation sheet:

Date:

Time:

Weather: Sunny/ Rainy /Cloudy etc.

Location:

Species	Number of Individuals	Phenological stage	Remarks

### 4. To study the impact of climate on sacred grove biodiversity

Sacred groves are the ecosystems conserved through traditional belief systems in particular localities. They have played significant role in conservation and preservation of biological resources. Students can document the changes in sacred groves through questionnaire survey and collect the climatic information from secondary sources and study the relationships.

#### Objectives

1. To understand the component of the sacred groves and the changes in sacred grove in last 2 decades
2. Study the changes in sacred groves with respect to the weather and climate

#### Methodology

- At the very outset we need to collect information from the village headman/priest and elderly people regarding existence of sacred groves in the vicinity of the study area.
- The sacred grove needs to be visited for the pilot survey along with teacher.
- During the pilot visit the main features of the grove such as the deity, belief system, use of resources and biodiversity have to be recorded.
- Then the main questions regarding sacred groves to be prepared for documentation of biodiversity and degradation.
- The historical data can be compared with the current data to make us understand the changes taking place in the sacred groves.
- Meantime the information regarding weather and climate can be collected from secondary sources and can be correlated with change in sacred grove.

### **Carbon sequestration - Forests trap carbon in the soil**

Plants use the sunlight to combine carbon dioxide and water into starch. The new research shows that vast amounts of it are pumped down to fungi deep in the ground, keeping the carbon out of the atmosphere and keeping the climate cool.

Some of the energy-rich starch molecules are kept in the plants, and then is often eaten by herbivorous animals or reaches again the soil through fallen leaves to be gobbled up by microscopic organisms. But some of the sugar is pumped down to the roots and traded with mycorrhizal fungi in exchange for nutrients.

The mycorrhizal fungi take the starch from the plants, and in return they feed nutrients to the plants. Fungi send stretching tentacles, called mycelia, through the ground to forage for nitrogen, phosphorous and other nutrients that are valued by the plants. They use those nutrients as currency with which they buy starch.

The sugar that's passed from the plant to the fungi contains lots of carbon, which the plant originally sucked out of the air as carbon dioxide. Scientists have discovered that most of the carbon that's stored in some forest floors is sequestered in the bodies of the dirt-dwelling fungi — not, as had been presumed, in the decomposing leaf litter. The researchers discovered that 50 to 70 percent of stored carbon in the forests was locked up in the root layer, where the mycorrhizal fungi thrive.



Illustrated by Perry Shirley (taken from web)

### **Box2. Foliar Water Uptake - Climate matters in the ecosystem** **Foliar Water Uptake**

All of us know that the water enters the roots from moisture in the soil and is sucked up the trunk through straw-like xylem to the leaves, where some evaporates. The combined effects of water tension and water cohesion inside the xylem and evaporation from the leaves keeps the water flowing against the force of gravity. A study of trees growing on Costa Rican mountains revealed that some high-altitude species can do the opposite way. When the soil is parched and their canopies are saturated by clouds, these trees use their leaves to suck water out of the air and then send the moisture back toward their trunks. “Water is still moving along a gradient from areas with more water to areas with less water. The clouds that nurture these cloud forests are evaporating as the planet warms, meaning the cloud-drinking strategy could doom those trees that rely upon it. That would be bad news for the birds and other wildlife that live in cloud forests, which are some of the world’s most striking and biodiverse ecosystems. “This phenomenon of water from clouds entering leaves — foliar water uptake — indicates a much tighter relationship between clouds and cloud forest plants than previously known.





*Sub Theme 4*

**WEATHER, CLIMATE,  
SOCIETY & CULTURE.**



# Weather, Climate — Society and Culture

## Background:

**Weather** is the condition of the atmosphere at particular place and time<sup>1</sup>; with respect to the variables like temperature, air pressure, wind, precipitation, etc.<sup>2</sup>

On the other hand **climate** is the regular pattern of weather conditions of a particular place<sup>1</sup>; a region of Earth having particular meteorological condition<sup>3</sup>. It can also be defined as the conditions of the atmosphere near the Earth's surface at certain location on Earth. But there are distinct differences with weather. Weather changes from day to day or season to season and also change in a regular cycle during the year. Climate is broadly a long term condition of weather pattern taken over a period of at least thirty years of a region.<sup>4</sup>

**Society** is a group of people with common territory, interaction, and culture. Society evolved through formation of groups from family to occupation based to interest based groups, etc. It may vary from region to region on the basis of natural environmental situation over different time scales. time. Because with the variation of space and time human interface with natural environment changes and human beings acquire different information and knowledge. Based on such practical experience and knowledge human beings designed their way of life, which is linked to formation of different social groups and with its elements of similarities, differences, cooperation, interdependence, social relationship, organization, etc.

**Culture** is everything made, learnt, or shared by the members of a society, including values, beliefs, behaviours, and material objects. Culture is learnt, and it varies tremendously from society to society.<sup>5</sup> "A culture is the totally acquired way of life or life style for a group of people. It consists of the patterned, repetitive ways of thinking, feeling and acting that are characteristics of members of a particular society or segment of a society".<sup>6</sup>

Weather and climatic condition of an area exerts impact on available natural resources and these natural resources provides opportunities and hurdles for human beings for designing their livelihood practices leading to formation of social groups and sub-groups and their cultural practices.

## Issues to understand?

The interface of weather and climate with human life is not so simple, rather it is a complex interaction linking many aspects of physical and social environment through evolution of cultural landscape on a natural landscape ( as in model-I)<sup>7</sup>.

This relationship of nature and culture in the context of influence of weather and climate on human society and culture streamline through human life style, evolved around their occupation, food system, housing or shelter, technology and material uses etc ( as in fig.1). Here, when the life style becomes less material and energy dependent

it may have less impact on weather and climatic factors on the other hand when it is more material and energy intensive its impact on weather and climate will be more. Such interrelationship varies with human knowledge and information, and more specifically with uses of technology. “Technological inventions or use of technology alter the means of subsistence and influence the structure and ideological sectors of culture”.<sup>8</sup> So, cultural value changes have relationship with life style changes which has distinct impact on weather and climatic association. In today’s world, increase of human population and proliferation of material intensive socio-cultural practices lead to problems like climate change. Therefore, IPCC’s analysis explains that “global Green House Gases (GHG) emission grew up due to human activities since pre-industrial times, it has seen an increase of 70% between 1970 and 2004. Atmospheric concentrations of CO<sub>2</sub>, methane (CH<sub>4</sub>) and nitrous oxide (N<sub>2</sub>O) have increased markedly as a result of human activities since 1750 and now far exceed pre-industrial values determined from ice cores spanning many thousands of years. Human influences are there with increase of temperature, changes in wind patterns, hot night, cold day, heat wave, draught, sea level rises “.<sup>9</sup>

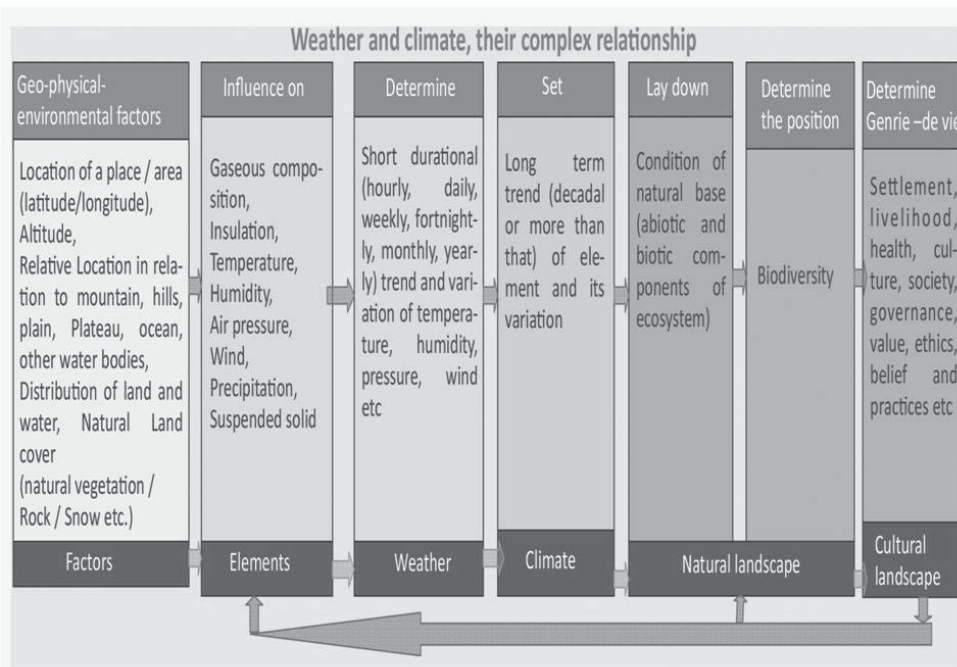

(Source: Manual no -03, “Weather and Climate” of the Manual in the series “Explore and understand your environment, people and their practices” developed for VIPNET Club of Vigyan Prasas , Edited by J.K. Sarma, B.K. Tyagi, SSEAEP, 2014,p. 10. )

The flowchart given above represents the complex situation of weather and climate related factors, influences of weather and climate on natural and cultural landscape. Usually, the physical environmental factors determine basic condition of weather elements like position of a place on the globe (in relation to latitude and longitude), determines pattern of solar energy availability and seasonal variability, which in turn influences temperature and associated features. In a similar manner, each of the factors has their influence and determines the weather and climatic conditions. The specific condition of weather and climate frame the base of natural landscape and on the basis of resources and opportunity human beings design

their way of life (Genrie-de vie),resulting in formation of cultural landscape. Moreover these human activities and their design cultural landscape exert influence on natural landscape as well as on elements of weather. These relationships are dynamic and vary over space and time.

**Model-I**

(Source: Manual no -03, “Weather and Climate” of the Manual in the series “Explore and understand your environment, people and their practices” developed for VIPNET Club of Vigyan Prasas , Edited by J.K. Sarma, B.K. Tyagi, SSEAEP, 2014,p. 10. )

These are the overt situations of Climate Change (CC). This trend of CC has negative impact on human way of life by destabilizing practices related with food production, natural resource base like water, land and soil, biodiversity etc. These may link to further destabilization of society through climate induced migration, food crisis, disaster etc. IPCC also observed that discrimination in society may worsen the situation (box-1). However, there is also some

hope. There are many practices among indigenous groups and their social system which may provide some ways for resilience and adaptation through their traditional ecological and technological knowledge (Box-2). So, UNFCCC stated that” “Indigenous, local, and traditional knowledge systems and practices, including indigenous peoples’ holistic view of community and environment, are a major resource for adapting to climate change; but these have not been used consistently in existing adaptation efforts. Integrating such forms of knowledge with existing practices increases the effectiveness of adaptation”.<sup>10</sup>

Fig. 1. Broad view on Weather-Climate and socio-cultural interlinks

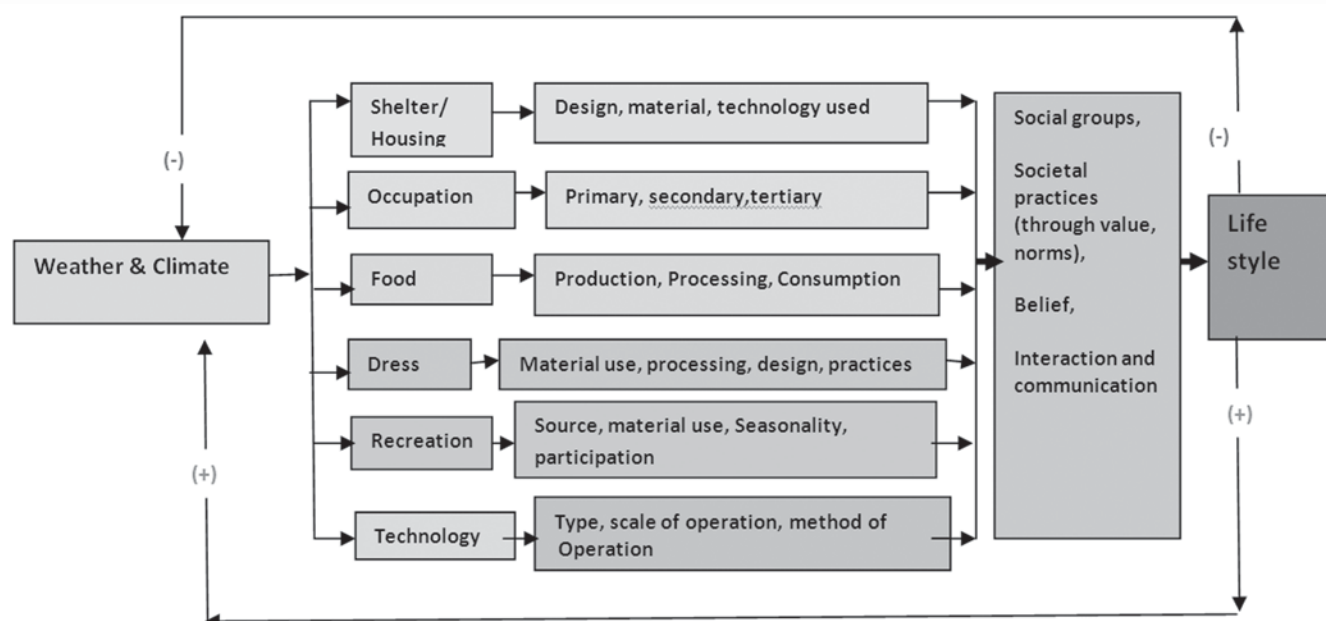

**Index –**

(+) – means positive life style (climate smart life style) and positive impact (which foster either mitigation or adaptation processes);  
 (-) negative life style (may be carbon intensive or destabilize carbon sink) and impact (contribute more green houses gases, reduce or destroy carbon sink and unable to strengthen mitigation or adaptation processes)

**Differences in vulnerability and exposure arise from non-climatic factors and from multidimensional inequalities often produced by uneven development processes (*very high confidence*). These differences shape differential risks from climate change.**

People who are socially, economically, culturally, politically, institutionally, or otherwise marginalized are especially vulnerable to climate change and also to some adaptation and mitigation responses (*medium evidence, high agreement*). This heightened vulnerability is rarely due to a single cause. Rather, it is the product of intersecting social processes that result in inequalities in socioeconomic status and income, as well as in exposure. Such social processes include, for example, discrimination on the basis of gender, class, ethnicity, age, and (dis)ability.

Source: IPCC WGII AR5 Summary for Policymakers, page-7

Box-2. The precipitous rise in the world's human population and humankind's ever-increasing dependence on fossil fuel-based ways of living have played a significant role in raising the concentration of atmospheric greenhouse gases (GHG). As a result, global temperatures are increasing, the sea level is rising, and patterns of precipitation are changing. At the same time, storm surges, floods, droughts and heat waves are becoming more frequent and severe. The consequent decline in agricultural production, increasing freshwater scarcity, and spread of infectious diseases, are degrading local livelihoods and diminishing human wellbeing around the world. Indigenous people are the ones affected by the climate change the most, although they have contributed little to its causes. This is largely a result of their historic dependence on local biological diversity, ecosystem services and cultural landscapes as a source of their sustenance, wellbeing, and resilience. Indigenous peoples, however, are not mere victims of climate change. Comprising only four per cent of the world's population (between 250 to 300 million people), they utilize 22 per cent of the world's land surface. In doing so, they maintain 80% of the planet's biodiversity in, or adjacent to, 85% of the world's protected areas. Indigenous lands also hold hundreds of gigatons of carbon — a recognition that is gradually dawning on industrialized countries that seek to secure significant carbon stocks in an effort to mitigate climate change. ***Indigenous peoples are excellent observers and interpreters of change on the land, sea, and sky. Their community-based and collectively held traditional knowledge accumulated and maintained through practice over countless generations, offers valuable insights into the state of the environment. Indigenous knowledge possesses chronological and landscape-specific precision and detail that is often lacking from scientific models developed by scientists at much broader spatial and temporal scale, including those used to understand the magnitude of climate change consequences. Moreover, indigenous knowledge provides a crucial foundation for community-based adaptation and mitigation actions that can sustain resilience of social-ecological systems at the interdependent local, regional, and global scales.***

Source: <http://newswatch.nationalgeographic.com/2012/02/06/thclimate-change-indigenous-knowledge/> (retrieved on June 25, 2014)

India's weather and climate are mainly governed by her geographical location, surrounding boundary conditions (the Himalayas, the Indian Ocean, Arabian Sea and Bay of Bengal). Further, the variations in land and water distribution within the country, altitudinal differences, vegetation type and cover along with the variations of sunshine hours within the country due to its latitudinal and longitudinal extension formed different climatic and agro-climatic zones. There are six climatic zones derived recently based on 0.5° X 0.5° grid level rainfall data and average potential evapo-transpiration for 144 stations located across India to compute moisture index needed for delineation of different climatic zones based on datasets refer to the period 1971–2005. These areas are – ***arid, semi-arid, dry sub-humid, moist sub-humid, humid, per humid*** (as in map 1)<sup>11</sup>. Similarly a total of 127 agro-climatic zones (table-1) have been identified in India under National Agricultural Research Project (NARP) based on a comprehensive research review of each state. While delineating zonal boundaries the physiographic divisions of each of the state, its rainfall pattern, soil type, availability of irrigation water, existing cropping pattern and administrative units have been considered in such a manner that there are fewer variations on the parameters within a zone. Now in this context if we look into people, their livelihood practices, socio-cultural practices in relation to food, shelter, clothing; uses of water, energy and technology, we may be able to identify wide variation. In each climatic and agro-climatic zone, its practices are influenced by respective weather and climatic attributes along with condition of topography, land,

water, soil and biodiversity. There are many to encouraging practices related to natural resource management and biodiversity conservation based on traditional knowledge systems<sup>12</sup>, like water harvesting<sup>13,14</sup>, land use management<sup>15</sup>, conservation practices<sup>16,17,18</sup>, settlement and housing practices<sup>19,20</sup>etc having different components that can strengthen climate change resilience and adaptation system. However, there are some practices which have negative impact on natural assets in general and weather influencing factors in particular<sup>21, 22, and 23</sup>. Relook to in these situations from the perspective of understanding and following **‘what, where, why and how’** question; these may reveal new know-how, skills and techniques to face the challenges of climate change. It may also strengthen our capability to develop a “climate smart” life style.

### Focused research question:

- What type of influences exerted by weather and climate related factors impact human social and cultural practices?
- What are the negative factors of human practices of a particular social and cultural framework which impinge on weather and climatic condition or its associated factors?
- Where are such influences prominent?
- Why such influences do exist or existed?
- How does weather and climatic factors influence human social and cultural practices?
- How socio-culturally defined human practices affect the weather and climatic situation or its associated factors?
- How do human beings try to get accustomed with such situations and re-design their life style?
- How the knowledge and technology help in strengthening their resilience and adaptation system?

### Framework

In the broad perspective of the aforesaid queries and in relation to model-I and fig.1, it is better to follow the framework (as in fig.2) to design a study in this sub-theme.

Fig.2. Framework to design study under the sub-theme of “Weather-climate: society and culture”

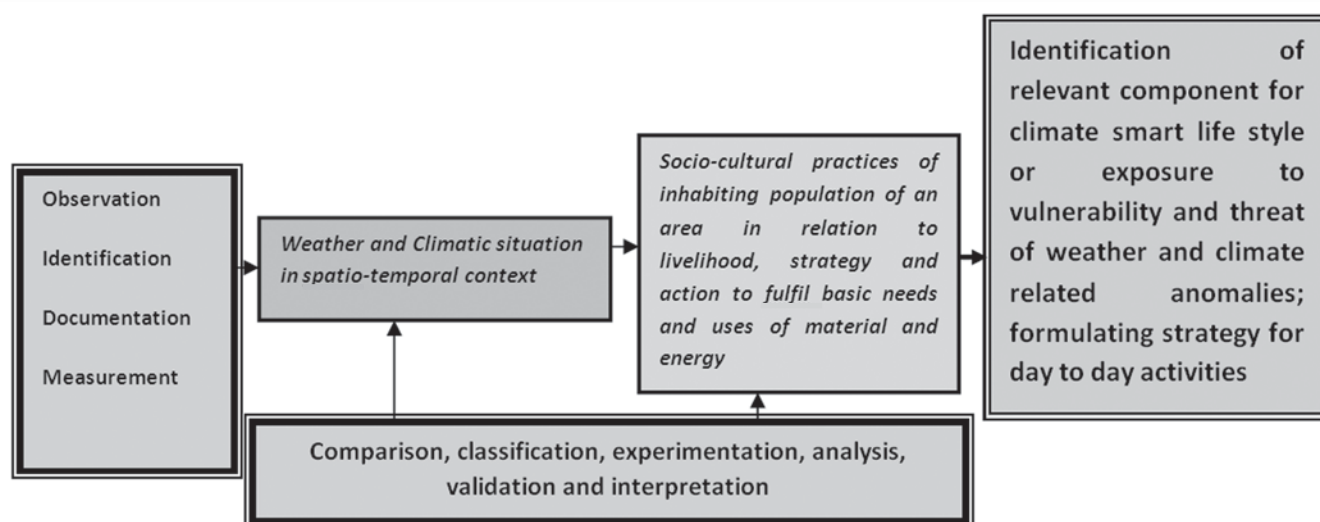

**Map-1. Climatic Zone of India**

(Climatic classification at district level (1971–2005).

(Source: *CURRENT SCIENCE*, VOL. 105, NO. 4, 25 AUGUST 2013, p.495)

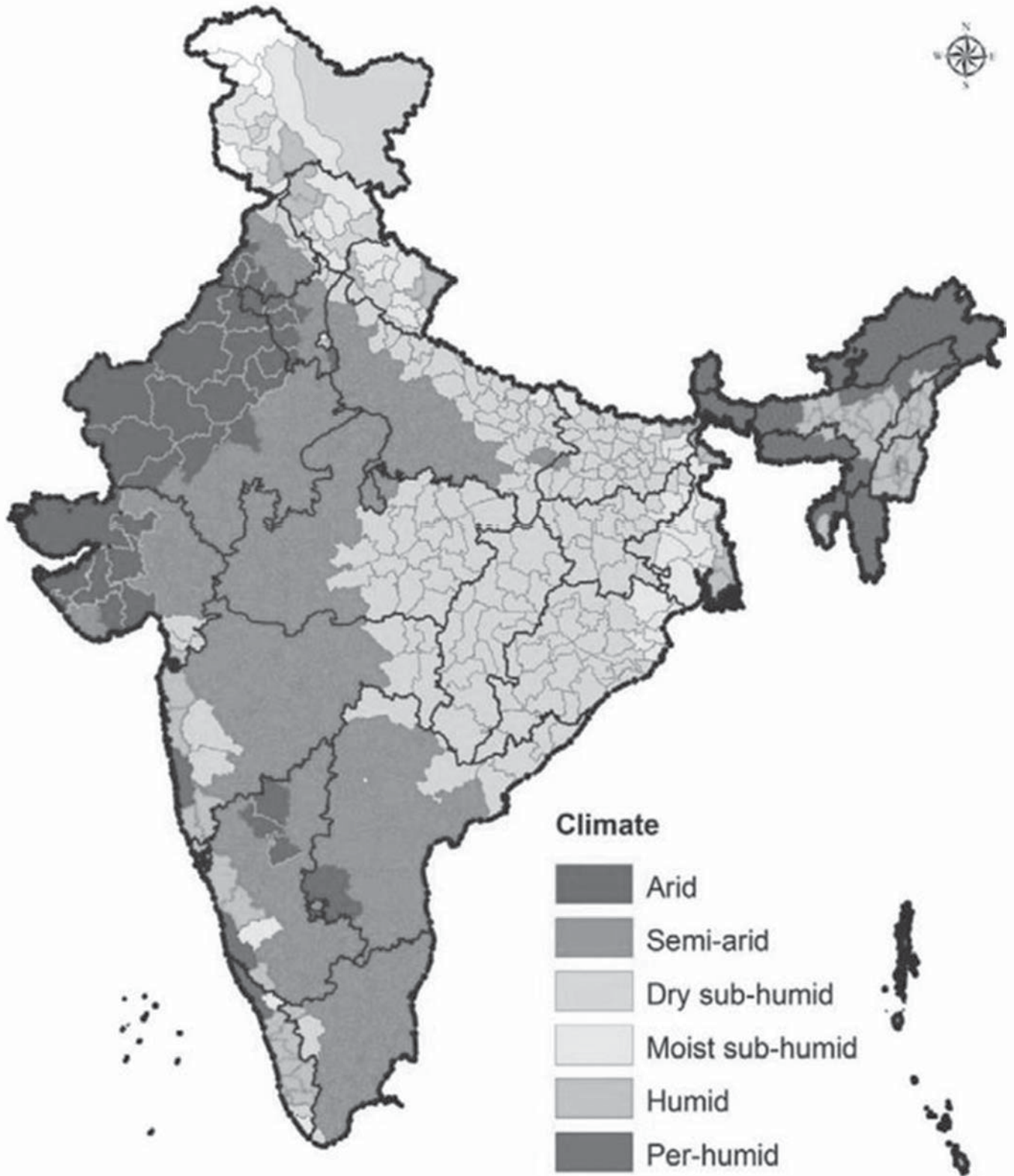



**Table -1. Agro-climatic zones of India**

Region: North India

Abbrivation

Agroclimatic Zone

**State : Jammu & Kashmir**

AZ1 Low Altitude Subtropical

AZ2 Intermediate

AZ3 Valley Temperate

AZ4 Dry Temperate

AZ5 Cold Arid

**State : Himachal Pradesh**

AZ6 High hills Temperate Wet

AZ7 Sub Montane and low hills subtropical

AZ8 Mid hills subtropical

AZ9 Sub Montane and low hills subtropical

**State : Punjab**

AZ10 Undulating Plain

AZ11 Central Plain

AZ12 Western Plain

AZ13 Western

AZ14 Sub montane undulating

**State : Haryana**

AZ15 Eastern

AZ16 Western

**State : Rajasthan**

AZ17 Arid Western Plain

AZ18 Irrigated North Western Plain

AZ19 Transitional plain zone of Island Drainage

AZ20 Transitional plain zone of Luni Basin

AZ21 Semiarid eastern plain

AZ22 Flood prone eastern plain

AZ23 Sub humid southern plain and alluvial hill

AZ24 Southern humid plain

AZ25 South eastern humid plain

**State : Uttarakhand**

AZ26 Hill

AZ27 Bhabar and Tarai

**State : Uttar Pradesh**

AZ28 Western Plain

AZ29 Mid Western Plain

AZ30 South Western Semi arid

AZ31 Central Plain

AZ32 BundelKhand

AZ33 North Eastern Plain

AZ34 Eastern Plain

AZ35 Vindyan

**Region : East & North east India****State : West Bengal**

AZ36 Hilly

AZ37 Tarai

AZ38 Old Alluvial

AZ39 New Alluvial

AZ40 Laterite and red soil Zone

AZ41 Coastal Saline

**State : Assam**

AZ42 Barak valley

AZ43 Upper Brahamaputra

AZ44 Hill

AZ45 Central Brahamaputra valley

AZ46 AZ47

AZ47 Lower Brahamaputra valley

**State : Arunachal Pradesh**

AZ48 Alpine

AZ49 Temperate Sub Alpine

**State : Meghalaya**

AZ50 Sub tropical Hill

**State : Manipur**

AZ51	Sub tropical plain
<b>State : Nagaland</b>	
AZ52	Mid Tropical Hill
<b>State : Tripura</b>	
AZ53	Mid Tropical Plain
<b>State : Bihar and Jharkhand</b>	
AZ54	Northwest Alluvial Plain
AZ55	North east Alluvial plain
AZ56	South Bihar Alluvial Plain
AZ57	Central and northeastern plateau
AZ58	Western Plateau
AZ59	South eastern plateau
<b>State : Odisha</b>	
AZ60	North western plateau
AZ61	North Central plateau
AZ62	North eastern Coastal plain
AZ63	East & southeastern coastal plain
AZ64	North eastern ghat
AZ65	Eastern ghat highland
AZ66	Southeastern ghat
AZ67	Western undulating
AZ68	West central table
AZ69	Mid Central table land
<b>Peninsular India</b>	
<b>State:Madhya Pradesh and Chattisgarh</b>	
AZ 70	Chattigarh plain zone including Chattisgarh districts
AZ71	Bastar Plateau
AZ72	North hill zone of Chattisgarh
AZ73	Kymora plateau and Satpara hill
AZ74	Vindya Plateau
AZ75	Central Narmada Valley
AZ76	Gird

AZ77	Bundelkhand
AZ78	Satpura plateau
AZ79	Malwa Plateau
AZ80	Nimar Valley
AZ81	Jhabua hills
<b>State: Gujarat</b>	
AZ82	East Gujarat heavy rainfall
AZ83	South Gujarat
AZ84	Middle Gujarat
AZ85	North Gujarat
AZ86	North Western Gujarat
AZ87	South Saurashtra
AZ88	North Saurashtra
AZ89	Ghat and Coastal
<b>State : Maharashtra</b>	
AZ90	South Konkan Coastal
AZ91	North Konkan Coastal
AZ92	Western Ghat
AZ93	Submontane
AZ94	Western Maharashtra Plain
AZ95	Scarcity
AZ96	Central Maharashtra plateau
AZ97	Central Vidarbha
AZ98	Eastern Vidarbha
<b>State : Karnataka</b>	
AZ99	North East transition
AZ100	North east dry
AZ101	Northern dry
AZ102	Central dry
AZ103	Eastern dry
AZ104	Southern dry
AZ105	Southern transition
AZ106	Western transition

AZ107	Hill
AZ108	Coastal
<b>State : Kerala</b>	
AZ109	Northern
AZ110	Southern
AZ111	Central
AZ112	High Altitude
AZ113	Problem area
<b>State : Andhra Pradesh</b>	
AZ114	North Coastal
AZ115	Southern
AZ116	Northern Telengana
AZ117	Scarce rainfall zone of Rayalseema

AZ118	Southern Telengana
AZ119	High altitude and tribal
AZ120	Krishna Godavari
<b>State : Tamil Nadu</b>	
AZ121	North eastern
AZ122	North western
AZ123	Western
AZ124	Kavery delta
AZ125	Southern
AZ126	High rainfall
AZ127	High altitude and hilly
(Source: <a href="http://www.imdagrimet.gov.in/node/3535">http://www.imdagrimet.gov.in/node/3535</a> , retrieved on June 26, 2014 )	



In the above pictures Which one is more appropriate? How to measure and analyse, create a locally viable design?

**Some images to ponder.**

**What? Where? Why & How, in the context of weather and climate.**

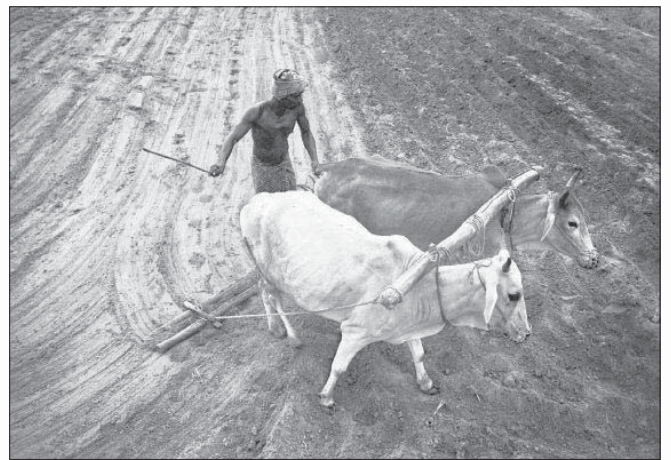



**(These are some example only. Similarly if we look into different walks of our day to day life different issues can be identified for detail study to understand the situation from weather, climate - society & culture perspectives.)**

**PROBABLE PROJECT OUTLINES:****1. Project title: Assessing Climate resilient components in the seasonal food behaviour and practices among the community of an area.****Background:**

Food is one of the basic needs of human being. Food selection, preparation, nature of food serving and consumption are postulated socio-culturally in majority of the cases. Such food practices have some seasonal variation; it may vary from summer to winter. Usually it is determined by the production system which assures the supply condition. As the production is related with weather condition, consumption pattern may be seasonal in nature. Some time specific food value or benefit from food may be able to fulfil the seasonal health requirements too.

But how people are rigid or flexible to a particular food; how particular food's production and processing systems are favourable to different conditions of weather are important components of its potentiality to face the challenges of weather related anomalies. For example, if a particular food product is grown in less rainfall and drought like condition or in high rainfall and waterlogged/flood or in both situations, that will determine its ability to cope up in vulnerable condition. When it is grown in both the situations, it has more resilience in case of production. Similarly, if processing of that particular food requires less energy, time and human labour, it has some quality which may help to reduce energy consumption, save time and labour (which are some requirements of climate smart system). Food like this may provide better reliability in all condition.

So, analysis of such aspects through a systematic study can help us develop an inventory of local food to develop a climate smart food system.

**Objectives:**

- To know about seasonal variation of food practices among the community residing in an area.
- To identify potentiality of this food in production, processing and consumption in relation to weather condition and weather related anomalies.
- To identify potential food items ideal to different seasons and resistant to seasonal weather related anomalies.

**Methodology:**

- Select a particular human settlement/residential area and identify the communities/cultural groups living in the area;
- Conduct a survey taking household as the basic unit of observation and collect information on their food practices in different seasons ( in this case following information are very much essential)
  - Type of food use against season;
  - Source of production, growing season, essential condition or requirement for production ( if such information are unable to provide by the specific household, collect it from local farmers or agricultural experts);
  - Involved system of processing ( like debarking, grinding, etc) and energy and material uses for the purpose along with amount of requirement;

- System of cooking ( boiling, steaming, frying, etc) and requirement of energy, additional material, labour and time;
- Reasons of taking a particular food in certain season;
- Set up some experiments to validates the collected information related to production, processing and cooking, through comparing data of experiments with the data collected from the households;
- Compiles the collected and experimental data, compare, analyses, classify the same to identify suitable food item, processing and cooking system which can help in developing a climate smart life style.

## **2. Project title: Study on prediction of weather through phenology of tree or insect behaviour**

### **Background:**

There are many weather prediction practices among the indigenous people based on their traditional knowledge system. Traditional weather forecaster relies on observation of phenology of certain plants and behaviour of certain animals as indicator of wet or dry years or onset of rainy season or dry years or adverse weather condition.<sup>24</sup> For example, many tribal people predict rainfall variation based on the flowering phenology of night flowering Jasmine ( *Nyctanthesarbortristis* L.; verbenaceae).<sup>25</sup> Similarly in the arid zone of Rajasthan and Gujarat people consider phenology of 'Kair' ( *Caparisdeciduas*) as an indicator of drought or normal monsoon. "Kair will be fully laden with flowers and fruits if there are drought and high temperature, where as in case of good monsoon, it bears only average flowers and fruits".<sup>26</sup>In Mizoram Hmar people consider insect like Cricket and Termite as indicators of weather. According to them "if a Cricket (*Gryluapensylvanicus*) brings new soil particles out of its hole during the dry season, rain will be coming. When winged Termite (*Phingpuihup*) come out of the soil in a group after a rainfall, rain will not come again for some time".<sup>27</sup>So, there may be similar practices in other places, among other communities too. **Identification, documentation and validation** of such information can provide us new set of indicators for weather prediction.

### **Objectives:**

- To Observe, identify and document the indigenous weather forecasting practices based on phenology of plant or behaviour of animal.
- To validate the collected information of the practices in view of scientific principles.
- Developing some sets of bio-indicators for weather forecasting.

### **Methodology:**

- Select an area for the study;
- Interact with local people and conduct survey to know about people's beliefs and practices on weather forecasting;
- Identify actual practitioner, collect information from them through face to face interview. Collect information about bio-indicator used by the particular person, documentation of information of last two/ three forecasting with month and year ( if possible date also);
- Collect the information about particular species used for weather prediction, habitat detail, weather and

climatic requirement, phenology ( in case of flora), food and reproduction behaviour ( in case of fauna);

- Collect weather related information of those days, months of the year for which gave the practitioner given his/her observation information from a weather station nearby;
- Compare the information given by the practitioner with the collected information of weather station; assess the variation and consistency of observational facts'
- Repeat the observation through self initiation, verify again with station data;
- Through comparative analysis identify the consistency and find out appropriate prediction practices.

### **3. Project Title: Study on thermal comfort of traditional housing assessing indoor temperature.**

#### **Background:**

Traditional housing designs have evolved through time as an adjustment process to local weather and climatic condition of the area to enhance the level of safety and security and assure the level of comfort. In the process focus on utilization of locally available building materials which are specific to that area also get highlighted. Usually uses of building materials for floor, wall, roof, etc are selected on the basis of their specific requirements. The orientation and ventilation of houses are also determined by the local condition of weather and climate, particularly temperature, wind, precipitation, sun shine hours, humidity etc. Therefore, there is significant variation of traditional housing design from high Himalayas to plains, desert and coastal region. There are significant observations in certain research; a study in Jharkhand on mud houses indicates that “mudhouse provides an insight for designing an energy efficient rural house that provides thermally comfortable conditions, as well as leaving behind a very low environmental footprint. The various parameters which were considered in the study of the existing mud house are – orientation, plan-form, building exposure to sun, surface-volume ratio, openings, shading, building envelope material, roofing materials and ventilation. The study observed insulating property of thatches is more than mud tiles in case of roof materials. So, thatch roofing houses are cooler than the mud tile roofing houses”.<sup>28</sup> Similarly one can carry out some studies to identify ideal thermally comfortable houses among the traditional houses, where available energy is utilized efficiently for heating, cooling, lighting etc.

#### **Objectives:**

- To study the thermal comfort of traditional housing in relation to indoor temperature;
- To assess how it is linked with energy consumption for cooling, heating and lighting;
- To identify ideal housing design for the locality.

#### **Methodology:**

- Identify a locality where traditional houses are there;
- Observe and identify different traditional houses in terms of design and material used;
- At the same time identify some modern houses with different designs and materials used;
- Observe, identify and assess the building materials used in the building, its facing and ventilation, etc for both categories of houses;



- Measures the room temperature using suitable thermometer, at different period of time both in day and night. For this purpose fixed two or three room (if available) in each of the houses considered for observation. These measurement need to be taken both in traditional and modern houses. Keep the records separately for each of the houses of observation.
- Assess the humidity level in each of the houses (in each room of observation separately). For this purpose use wet bulb thermometer or design/adopt a separate way of alternative measurement.
- Now, compare the temperature of traditional houses with modern ones and find out the differences and also find out where it is lowest and where it is highest. Try to correlate humidity level with the temperature.
- Now find out best housing design and material use for thermal comfort in particular area.

### **SOME MORE PROJECT IDEAS:**

- Study the relationship between traditional/indigenous pest management practices and weather condition;
- Study the practices of traditional land use and land cover management and impact on weather and climate;
- Assess the impact of traditional water harvesting and management practices (like Johad, Vap, Kul, Longsor, Dong, etc) in developing sustainability of water resources in climate stress period and developing resilience system;
- Study the traditional practices of animal rearing and their health management, their relationship with weather condition and seasonality; identify components of adaptation and resilience;
- Study cultural priority on selection of food crop for cultivation in the locality and its relationship with local weather and climate induced disaster;
- Study on the efficiency of traditional utensil used for cooking and their contribution in reduction of energy and carbon emission;
- Comparative study of distribution of rainy days against month in traditional calendar system and English calendar system and find out the reliability aspects for agricultural planning;
- Study on fuel wood based cremation practices, assessment of carbon emission and developing alternative system for cremation;
- Assessment of energy requirement in traditional cooking and modern way of cooking, identify carbon emission factors and impact on weather and climate;
- Study on the alternative food sources of different cultural groups in disaster prone situation (like flood, drought, etc) and assessing its potentiality for building resilience and adaptation to climate change;
- Assess the energy consumption and pollution of air, water, noise during festival ( like Diwali, Pongal, MaghBihu, Durga Puja, etc ) and impact on developing resilience and adaptation to climate change;
- Study on the traditional food storage practices among the community and its relation to weather and climate;
- Prepare community based culturally adaptable Disaster Management Plan with proper assessment of risk and vulnerability for climate induced disaster of your locality.

### **References:**

1. Oxford advanced learner's dictionary, 2010;
2. <http://www.thefreedictionary.com/weather>, retrieved on June 20,2014
3. <http://www.thefreedictionary.com/climate>, retrieved on June 20,2014

4. Basu Biman "Earth's Changing Climate", Vigyan Prasar, 2012, p.2.
5. <http://www.sparknotes.com/sociology/society-and-culture/section5.rhtml>, retrieved June 22,2014
6. Harris Marvin (1971) "Culture, people, nature", Thomas Y Crowell,p.144.
7. Sarma JK and Tyagi B K ( edited ) "Weather and Climate" (Manual no -03) of the series on "Explore and understand your environment, people and their practices" developed for VIPNET Club of Vigyan Prasar , SSEAEP, 2014,p. 10
8. Harris Marvin (1971) "Culture, people, nature", Thomas Y Crowell,p.229.
9. IPCC "Climate Change 2007: Synthesis Report" [http://www.ipcc.ch/publications\\_and\\_data/ar4/syr/en/spms2.html](http://www.ipcc.ch/publications_and_data/ar4/syr/en/spms2.html) ,retrieved June 24,2014
10. FCCC/SBSTA/2014/INF.11,8 May 2014,( Reissued for technical reasons on 16 May 2014),<http://unfccc.int/resource/docs/2014/sbsta/eng/inf11.pdf> (retrieved on June 25,2014) also available in [http://ipcc-wg2.gov/AR5/images/uploads/IPCC\\_WG2AR5\\_SPM\\_Approved.pdf](http://ipcc-wg2.gov/AR5/images/uploads/IPCC_WG2AR5_SPM_Approved.pdf)>. as mentioned in the previous cited document
11. Raju B.M.K. et al (2013), "Revisiting climatic classification in India: a district-level analysis", *CURRENT SCIENCE*, VOL. 105, NO. 4, p. 492-495
12. Agarwal Anil and Narain Sunita "Fourth Citizens' Report [SOE-4]: Dying Wisdom "Centre for Science and Environment(CSE),New Delhi-110003
13. Sarma J.K. and Tyagi B.K. (edited) "Traditional Knowledge System" (Manual no -07) of the series on "Explore and understand your environment, people and their practices" developed for VIPNET Club of Vigyan Prasar , SSEAEP, 2014
14. Sarma J.K. and Tyagi B.K. (edited) "Water Resources" (Manual no -02) of the series on "Explore and understand your environment, people and their practices" developed for VIPNET Club of Vigyan Prasar , SSEAEP, 2014
15. Sarma J.K., Saikia R. (2013) " IEKS and sustainable land resource management- a surveillance on the practices among the Tangsa Naga and Tangkhul Naga of North East India" *Indian Journal of Traditional Knowledge*,Vol, 12(2),pp 252-258
16. Kothari A. And Pathak N. "Protected areas, community based conservation and decentralisation: lesson from India" a report under EPP,IUCN, ([http://www.kalpavriksh.org/images/CCA/Consultation/Report\\_CCAsEcosystemsProtectedAreasPeopleProject%20\(EPP\)IUCNWorldCommission\\_April2006.pdf](http://www.kalpavriksh.org/images/CCA/Consultation/Report_CCAsEcosystemsProtectedAreasPeopleProject%20(EPP)IUCNWorldCommission_April2006.pdf)) retrieved on June 20,2014
17. Chatterji S, Ghosh S , Sarma JK , et al (2011) " Community conserved area in North East India: some observation in Assam, Meghalaya and Arunachal Pradesh" in *The Indian Forester*, Vol.137,Issue.8a,
18. Sarma J.K. and Tyagi B.K. (edited) "Biodiversity" (Manual no -04) of the series on "Explore and understand your environment, people and their practices" developed for VIPNET Club of Vigyan Prasar , SSEAEP, 2014
19. BEST PRACTICES IN RURAL HOUSING <http://rural.nic.in/sites/downloads/our-schemes-glance/BestPractices.pdf> , retrieved on April 20,2014
20. Sarma J.K. and Tyagi B.K. (edited) "Our Settlement" (Manual no -05) of the series on "Explore and understand your environment, people and their practices" developed for VIPNET Club of Vigyan Prasar , SSEAEP, 2014
21. Khongsa C. " Jhum Cultivation and its impact on ecology, need for viable alternatives" [http://e-pao.net/epSubPageExtractor.asp?src=education.Science\\_and\\_Technology.Jhum\\_Cultivation\\_and\\_its\\_impact\\_on\\_Ecology](http://e-pao.net/epSubPageExtractor.asp?src=education.Science_and_Technology.Jhum_Cultivation_and_its_impact_on_Ecology), retrived on 18 June,2014
22. Mandal P , et al ( 2012) "Impact of Diwali celebrations on urban air and noise quality in Delhi City, India", *Environ Monit Assess.* 2012 Jan;184(1):209-15.

23. Singh D.P. et al (2009) “ Study of temporal variation in ambient air quality during Diwali festival in India” Environ Monit Assess. ,DOI 10.1007 /s10661-009-1145-9
24. Galacgae E S and Balisacan C M “ Traditional weather forecasting for sustainable agroforestrty practices in Ilocos Norte Province, Philippines” Forest Ecol. Manage. 257 (2009), 2044-2053
25. Acharya S ( 2011) “ Prediction of rainfall variation through flowering phenology of night –flowering jasmine (Nyctanthesarbortristis L.; verbenaceae) in Tripura” in Indian Journal of Traditional Knowledge, Vol.10(1),pp.96-101.
26. Singh D and Singh R K ( 2011) “ Kair (Caparisdeciduas) : a potential ethno-botanical weather predictor and livelihood security shrub of Arid Zone of Rajasthan and Gujrat” in Indian Journal of Traditional Knowledge, Vol.10(1),pp. 146-155
27. Chinlampinga M (2011) “ Traditional knowledge, weather prediction and bio-indicators – a case study of Mizoram, Northeastern India” in Indian Journal of Traditional Knowledge, Vol.10(1),pp 207-211
28. Gupta J “Sustainability of rural mud houses in Jharkhand: analysis related to thermal comfort” ([http://www.academia.edu/3887802/SUSTAINABILITY\\_OF\\_RURAL\\_MUD\\_HOUSES\\_IN\\_JHARKHAND\\_ANALYSIS\\_RELATED\\_TO\\_THERMAL\\_COMFORT](http://www.academia.edu/3887802/SUSTAINABILITY_OF_RURAL_MUD_HOUSES_IN_JHARKHAND_ANALYSIS_RELATED_TO_THERMAL_COMFORT), retrieve on June 25,2014)

### **Glossary of some important words mentioned in this document:**

**Adaptation:** Adjustment or preparation of natural or human systems to a new or changing environment which moderates harm or exploits beneficial opportunities.

**Adaptive capacity:** The ability of a system to adjust to climate change (including climate variability and extremes) to moderate potential damages, to take advantage of opportunities, or to cope with the consequences.

**Anthropogenic:** Made by people or resulting from human activities. Usually used in the context of emissions that are produced as a result of human activities.

**Carbon Footprint:** The total amount of greenhouse gases that are emitted into the atmosphere each year by a person, family, building, organization, or company. A persons carbon footprint includes greenhouse gas emissions from fuel that an individual burns directly, such as by heating a home or riding in a car. It also includes greenhouse gases that come from producing the goods or services that the individual uses, including emissions from power plants that make electricity, factories that make products, and landfills where trash gets dumped.

**Climate:** Climate in a narrow sense is usually defined as the “average weather,” or more rigorously, as the statistical description in terms of the mean and variability of relevant quantities over a period of time ranging from months to thousands of years. The classical period is 3 decades, as defined by the World Meteorological Organization (WMO). These quantities are most often surface variables such as temperature, precipitation, and wind. Climate in a wider sense is the state, including a statistical description, of the climate system.

**Climate change:** Climate change refers to any significant change in the measures of climate lasting for an extended period of time. In other words, climate change includes major changes in temperature, precipitation, or wind patterns, among others, that occur over several decades or longer.

**Climate Smart:** Concept of Climate Smart has evolved with designing and execution of responsible human activities in all walks of life, which can promote sustainable development, adapting and building resilience to climate change, reducing and/or removing green house emission. So, efficient uses of material and energy with maximization of benefit from little input along with responsible choice of material and energy for use are same of the best ways to step forward for such condition.

**Culture:** Culture is the totally acquired life way of life or life style for a group of people. It consists of the patterned, repetitive ways of thinking, feeling and acting that are characteristics of members of a particular society or segment of a society.

**Disaster management plan:** It is a planning to manage disaster. Such plans cover aspects of prevention, preparedness, relief and recovery. *Disaster prevention* is activities designed to provide permanent protection from disasters. *Disaster preparedness* is activities designed to minimise loss of life and damage – for example by removing people and property from a threatened location and by facilitating timely and effective rescue, relief and rehabilitation. Preparedness is the main way of reducing the impact of disasters. *Disaster relief* is a coordinated multi-agency response to reduce the impact of a disaster and its long-term results. Relief activities include rescue, relocation, providing food and water, preventing disease and disability, repairing vital services such as telecommunications and transport, providing temporary shelter and emergency health care. Disaster recovery means once emergency needs have been met and the initial crisis is over, the people affected and the communities that support them are still vulnerable. Recovery activities include rebuilding infrastructure, health care and rehabilitation.

**Emissions:** The release of a substance (usually a gas when referring to the subject of climate change) into the atmosphere.

**Mitigation:** A human intervention to reduce the human impact on the climate system; it includes strategies to reduce greenhouse gas sources and emissions and enhancing greenhouse gas sinks.

**Phenology :** The timing of natural events, such as flower blooms and animal migration, which is influenced by changes in climate. Phenology is the study of such important seasonal events. Phenological events are influenced by a combination of climate factors, including light, temperature, rainfall, and humidity.

**Resilience :** A capability to anticipate, prepare for, respond to, and recover from significant multi-hazard threats with minimum damage to social well-being, the economy, and the environment.

**Risk:** It is a situation involving exposure to danger.

**Society** is a group of people with common territory, interaction, and culture. Society evolved through formation of groups from family to occupation based to interest based group, etc.

**Social control:** Refer to social process by which behaviour and act of individuals or groups is regulated.

**Social engineering:** Planned social change and social development.

**Sensitivity:** The degree to which a system is affected, either adversely or beneficially, by climate variability or change. The effect may be direct (e.g., a change in crop yield in response to a change in the mean, range or variability of temperature) or indirect (e.g., damages caused by an increase in the frequency of coastal flooding due to sea level rise).

**Traditional Knowledge System:** A cumulative body of knowledge, practices and beliefs evolved by adaptive processes and handed down through generations by cultural transmission. This knowledge system incorporates a complex combination of belief, values and norms along with practices.

**United Nations Framework Convention on Climate Change (UNFCCC):** The Convention on Climate Change sets an overall framework for intergovernmental efforts to tackle the challenges posed by climate change. It recognizes that the climate system is a shared resource whose stability can be affected by industrial and other emissions of carbon dioxide and other greenhouse gases. The Convention enjoys near universal membership, with 189 countries having ratified.

**Vulnerability:** The degree to which a system is susceptible to, or unable to cope with, adverse effects of climate change, including climate variability and extremes. Vulnerability is a function of the character, magnitude, and rate of climate variation to which a system is exposed; its sensitivity; and its adaptive capacity.

**Weather:** Atmospheric condition at any given time or place. It is measured in terms of such things as wind, temperature, humidity, atmospheric pressure, cloudiness, and precipitation. In most places, weather can change from hour-to-hour, day-to-day, and season-to-season. Climate in a narrow sense is usually defined as the “average weather”, or more rigorously, as the statistical description in terms of the mean and variability of relevant quantities over a period of time.



*Sub Theme 5*

**WEATHER, CLIMATE  
& AGRICULTURE.**



# Weather, Climate and Agriculture

## Background

Agriculture, is the backbone of India, deals in the cultivation of plants, fungi, animals and other life forms for food, fodder, fibre, fuel wood, medicinal plants and other products used to sustain and enhance human life. Pre-industrial agriculture was typically subsistence agriculture in which farmers raised most of their crops for their own consumption. A remarkable shift in agricultural practices has occurred over the past century in response to new technologies, and the development of world markets.

Agriculture is closely dependent on the endowment of natural resources and environmental conditions of soil and climate. India is a land of many climates and varieties of soils, affording scope for much diversity in agriculture. In our country, more than 50 per cent of variation of crops is determined by climate. It is climate vis-à-vis weather plays an important role, probably more so in India where aberrant weather such as drought, flood, etc., is a rule rather than an exception.

With a geographic area of 328.76 million hectares, stretching between 8°N and 36°N latitude and between 68°E and 98°E longitude, its altitude varying from the mean sea-level to the highest mountain ranges of the world, India presents a range and diversity of climate, flora and fauna, with a few parallels in the world. The country presents a paradox of having highest mean annual rainfall in the world (Cherapunji / Mawsinram in Meghalaya) and also dry, semi-desert area in Rajasthan. The variability of rainfall is most important in all the states, especially where it is low. In parts of Rajasthan and the Deccan, such variability is more than 100 per cent of the mean rainfall. Years of drought account for a frequent history of crop failures, whereas the years of flood also cause very considerable loss of agricultural production.

Temperatures also vary greatly, both geographically and seasonally. In northern and central parts of India during pre-monsoon months, the maximum temperatures reach over 40°C over a large area. Further frost may occur in winter in the plains, as far south as a line drawn through Madhya Pradesh and may be heavier in Kashmir and areas north of Punjab including various other parts of the Eastern Himalayan range.

Considering the fact that weather plays an important role in efficient crop planning, proper understanding of agro-climatic conditions is essential. Planning Commission, Government of India in its 8<sup>th</sup> Plan has delineated 15 agro-climatic zones for agricultural planning in the country (Table -1), primarily on the basis of rainfall and evaporation which is the resultant effect of sunshine, temperature, wind and land use.

**Table-1. List of Agro-Climatic Zones in India**

1. Western Himalayan Region
2. Eastern Himalayan Region
3. Lower Gangetic Plains Region
4. Middle Gangetic Plains Region
5. Upper Gangetic Plains Region
6. Trans-Gangetic Plains Region
7. Eastern Plateau and Hills Region
8. Central Plateau and Hills Region
9. Western Plateau and Hills Region
10. Southern Plateau and Hills Region
11. East Coast Plains and Hills Region
12. West Coast Plains and Ghat Region
13. Gujarat Plains and Hills Region
14. Western Dry Region
15. The Islands Region

**SCENARIO OF RAINFED AGRICULTURE**

In agriculture, water is an important factor that affects or determines plant growth and development. Its availability or scarcity determines successful harvest, or diminution in yield, or even total failure of a crop. Rainfall is the primary source of water for crop cultivation and allied agricultural practices. Quantum and nature of distribution of rainfall vary with location and thereby affecting growth and yield of crops. Most plants are *mesophytes*, that are adapted to conditions with moderate supply of water. But *hydrophytes*, require watery or water-logged habitats, while *xerophytes*, are more tolerant to dry conditions. Alike other climatic factors, water too causes detrimental effect on growth and development of both plants and animals. Excess water in the soil can injure flood prone plants like corn (Maize), due to lack of oxygen..

Globally 80 per cent of the agricultural land area is rainfed that depends on rainfall for its successful crop production. The rainfed agriculture generates 65 to 70 per cent of staple foods. However, 70 per cent of the population inhabiting in these areas are poor due to low and variable productivity. India ranks first among the rainfed agricultural countries of the world in terms of both extent and value of produce. Rainfed agriculture is practiced in two-thirds of the total cropped area that accounts for 162 million hectares (66 per cent) and supports 40 per cent of the national food basket. Importance of such agricultural practice is obvious from the fact that 55 per cent of rice, 91 per cent coarse grains, 90 per cent pulses, 85 per cent oilseeds and 65 per cent cotton are grown in rainfed areas. These areas receive an average annual rainfall between 400 mm and 1000 mm. In certain areas, the total annual rainfall does not exceed even 500mm. As a result of such low and erratic monsoon rainfall, significant fall in food production is often noticed. Due to climate change, the country is also experiencing shift of onset of monsoon from its normal date coupled with erratic distribution and reduction in amount, which largely affected our crop production system vis-à-vis agriculture as a whole. Rainfed agriculture is highly vulnerable to climate change including raise in air temperatures and variation in rainfall. In last three decades India has experienced sharp rise in mean annual temperature, although most of the rainfed crops can tolerate high temperatures. However, rainfed crops grown



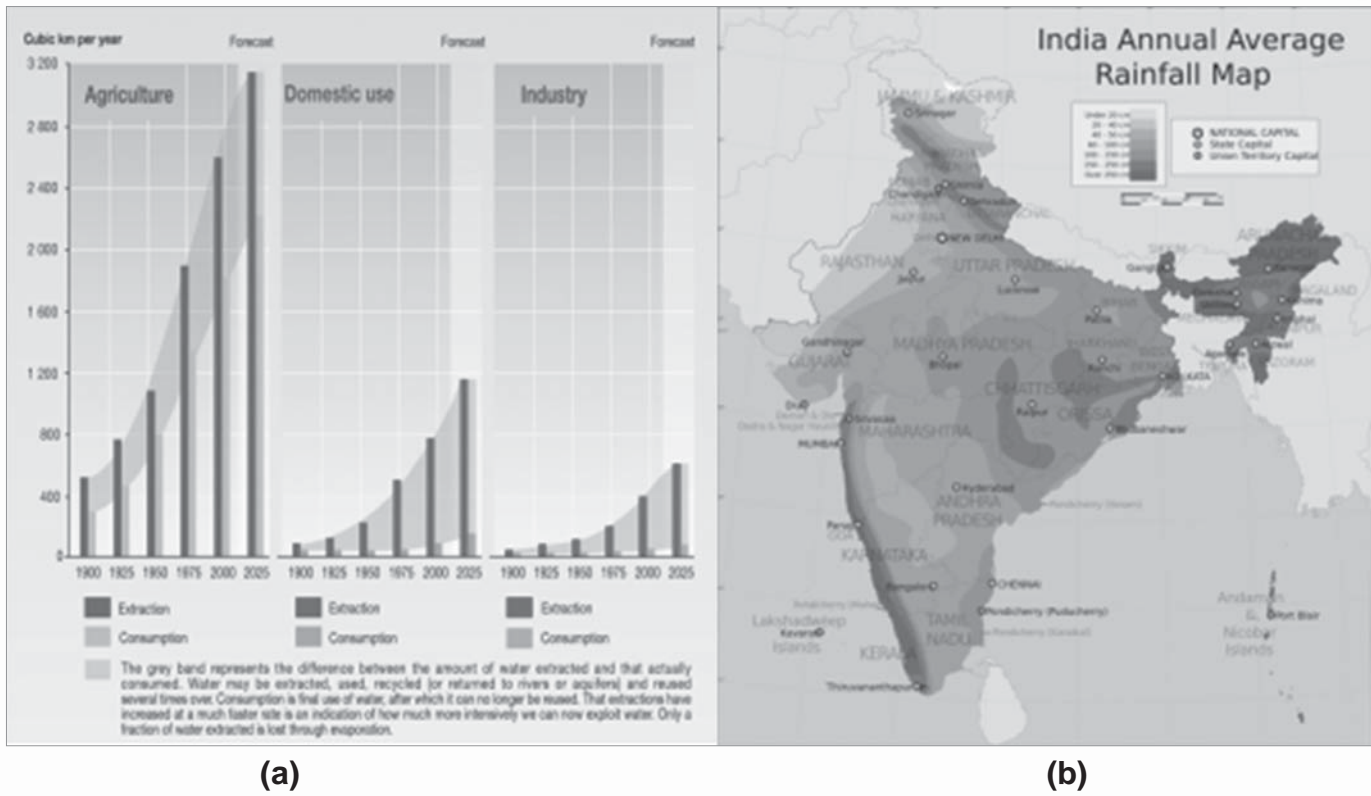

**Fig-1. (a) Past, present and predicted future consumption of water by Agriculture, domestic and Industrial sectors (b) Spatial distribution of mean Annual Rainfall over India**

during *rabi* are vulnerable to changes in minimum temperatures

Erratic rainfall and occurrence of frequent droughts bring tremendous change in both surface as well as ground water. Many scientists opined that region-specific analysis is required to evaluate in detail the agronomic and economic impact of weather changes. For example, in Dharwad District of Karnataka state wherein, 82 per cent of the net sown area was under rainfed condition during 2009-10, the yield of most of the crops decreased to a large extent due to drought condition (Table-2). Rainfall anomaly during 2009-'10 during the monsoon season over India is indicated in Figure-2.

**Table- 2. Effect of 2009-'10 Drought on the yield(kg/ha) of few Rainfed Crops in Dharwad district, Karnataka**

Crop	Per cent loss of normal yield
Sorghum	43.03
Maize	14.09
Tur	28.23
Groundnut	34.09
Wheat	48.68
Onion	29.56
Cotton	59.96

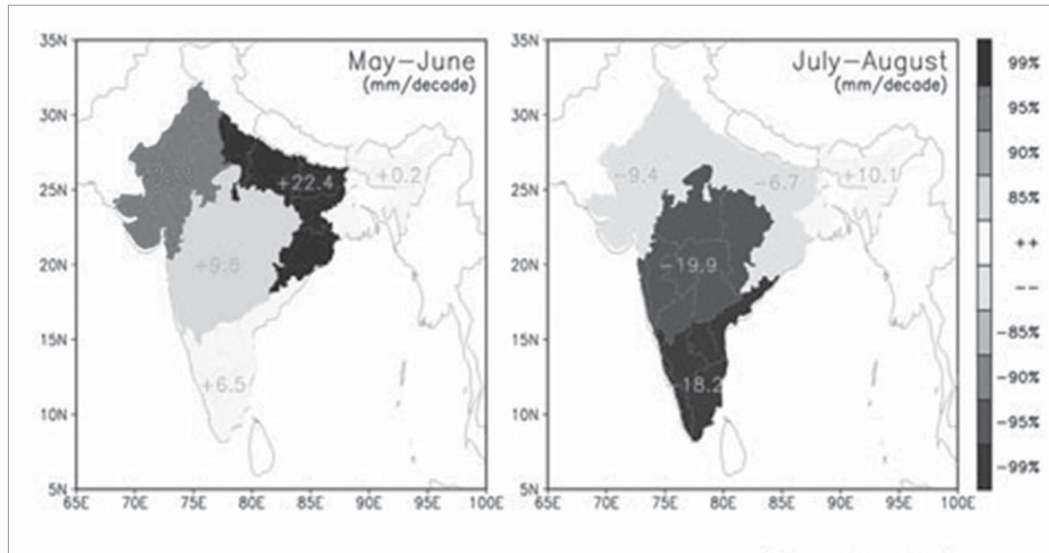

Fig-2. Deviation in Rainfall over India during 2009 -'10

## IMPACT OF CLIMATE CHANGE ON AGRICULTURE

The climate change is any change in climatic factors over time that is attributed directly or indirectly to human activity that alters the composition of the global atmosphere in addition to natural climate variability observed over comparable time periods (IPCC, 2007). Since climatic factors serve as direct inputs to agriculture, any change in climatic factors is bound to have significant impact on crop growth, yields and production. Studies have shown significant effect of change in climatic factors on the average crop yield.

India is likely to witness one of the highest agricultural productivity losses in the world as a consequence of climate change pattern observed and projected. Climate change projections made up to 2100 for India indicate an overall increase in temperature by 2-4<sup>0</sup> C with no substantial change or slight increase in precipitation. Due to anthropogenic influences such as increase in the use of fossil fuels, deforestation and urbanization already the symptoms of climate change are being observed in the arctic and Antarctic regions through melting of the frozen ice and the resultant submergence of coastal zones. The inundation of lands in the coastal zones as an effect of climate change will lead to salinization of land.

The Inter-Governmental Panel on Climatic Change (IPCC) in its 2001 report projected that the globally average temperatures may rise by 1.4°C to 5.8°C over the next 100 years. And for India, the area-averaged annual mean warming projected to be between 1.0°C and 1.4°C by 2020 and between 2.2°C to 2.9°C by 2050; though, the increase in temperatures would be less in *rabi* season (winter season). Further, the *kharif* (monsoon season) rainfall is expected to increase in most of the places whereas *rabi* rainfall may decrease in some areas. Though no immediate adverse impact of global warming is visible in India, experts feel the country should draw sharp strategy to deal with the long-term effects of climate change on agriculture. "Rise of 0.2 degrees in the temperatures now is not a cause of worry for agriculture in the country, but there could be a problem after 5-6 decades for which we need to be alert" says, S. Ayyappan, Director General of ICAR. Scientists at IARI (The Indian Agriculture Research Institute) conducted studies to evaluate potential climate change impacts on wheat and rice (India's primary and staple food crops), and also on sorghum and maize and indicated that the change in temperature, CO<sub>2</sub> levels, precipitation, and solar radiation affect crop's yield significantly.

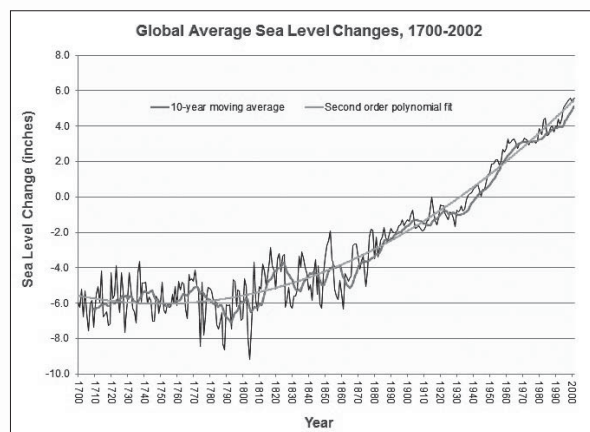

Fig.-3. Global Average Sea level Change, 1700-2002

But, in recent past, heavy rainfall events increased resulting floods, and occurrence of more intense droughts affecting agricultural and allied sectors (cropping cycle, population, and density of pollinators, flowering pattern, agricultural produce including animal production etc.) as an effect of climate change. On the contrary, modern agricultural practices (both above and below the ground) also play vital role in spurring climate change through release of greenhouse gases, depletion of soil carbon, desertification, salinization etc.

## POLLUTION AND AGRICULTURE

Agricultural crops can be injured when exposed to high concentrations of various air pollutants. Injury ranges from visible markings on the foliage, to reduced growth and yield, to premature death of the plant. The development and severity of the injury depends not only on the concentration of the particular pollutant, but also on a number of other factors like length of exposure to the pollutant, the plant species and its stage of development as well as environmental factors conducive to build-up the pollutant.

### Effects of Air Pollution

Air pollution injury to plants can be evident in several ways. Injury to foliage may be visible in a short time and appear as necrotic lesions (dead tissue), or it can develop slowly as yellowing or chlorosis of the leaf. There may be reduction in growth of various portions of the plant. Plants may be killed outright, but they usually do not succumb until they have suffered recurrent injury. Interaction between air pollution and climate is shown through figure-

### Effect of few air pollutants on plant has been described in nutshell below for better understanding.

**Oxidants:** Ozone is the main pollutant in the oxidant smog complex. Its effect on plants was first observed in Los Angeles area in 1944. Ozone symptoms characteristically occur on the upper surface of affected leaves and appear as a flecking, bronzing or bleaching of the leaf tissues. Although yield reductions are usually with visible foliar injury, crop loss can also occur without any sign of pollutant stress. Conversely, some crops can sustain visible foliar injury without any adverse effect on yield. High relative humidity, optimum soil-nitrogen levels and water availability increase susceptibility. Sensitive species include cucumber, grape, green bean, lettuce, onion, potato, radish, spinach, sweet corn, tobacco and tomato. Resistant species include pear and apricot.

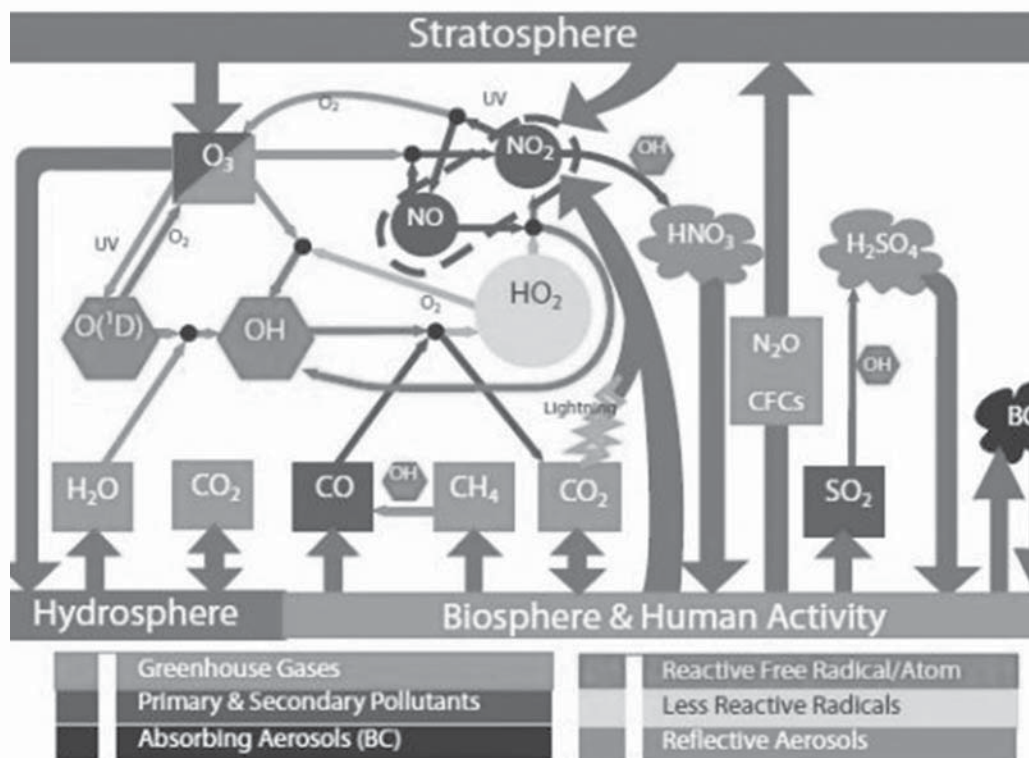

Fig.-4. Schematic diagram showing pollution of different spheres

**Sulfur Dioxide:** Sulfur dioxide enters the leaves mainly through the stomata (microscopic openings) and the resultant injury is classified as either acute or chronic. Acute injury is caused by absorption of high concentrations of sulfur dioxide in a relatively short time. The symptoms appear as 2-sided (bifacial) lesions that usually occur between the veins and occasionally along the margins of the leaves. The colour of the necrotic area can vary from a light tan or near white to an orange-red or brown depending on the time of year, the plant species affected and weather conditions. Recently expanded leaves usually are the most sensitive to acute sulfur dioxide injury, the very youngest and oldest being somewhat more resistant. However, different plant species vary considerably in their sensitivity to sulfur dioxide. These variations occur because of the differences in geographical location, climate, stage of growth and maturation. The crops those are generally susceptible to sulfur dioxide are alfalfa, barley, oats, pumpkin, radish, spinach, squash, and tobacco. Resistant crop plants include asparagus, cabbage, celery, corn, onion and potato.

**Fluoride:** Fluorides are discharged into the atmosphere from the combustion of coal; the production of brick, tile, enamel frit, ceramics, and glass; the manufacture of aluminum and steel; and the production of hydrofluoric acid, phosphate chemicals and fertilizers. The fluoride enters the leaf through the stomata and is moved to the margins where it accumulates and causes tissue injury. The injury starts as a gray or light-green water-soaked lesion, which turns tan to reddish-brown. With continued exposure the necrotic areas increase in size, spreading inward to the midrib on broad leaves and downward on monocotyledonous leaves. The characteristic dark band separating the healthy (green) and injured (brown) tissues of affected leaves is the usual symptom of fluoride pollution. Studies indicate that apricot, barley (young), peach (fruit), gladiolus, grape, plum, sweet corn and tulip are most sensitive; whereas, alfalfa, asparagus, bean (snap), cabbage, carrot, cauliflower, celery, cucumber, eggplant, pea, pear, pepper, potato, squash, tobacco and wheat are resistant.

**Ammonia:** Ammonia injury to vegetation usually occurs due to release of large quantities of ammonia into the atmosphere for brief periods of time and cause severe injury to vegetation in the immediate vicinity. Complete system expression on affected vegetation usually takes several days to develop, and appears as irregular, bleached, bifacial, necrotic lesions. Grasses often show reddish, interveinal necrotic streaking or dark upper surface discoloration. Flowers, fruit and woody tissues usually are not affected, and in the case of severe injury to fruit trees, recovery through the production of new leaves can occur. Sensitive species include apple, barley, beans, radish and soybean. Resistant species include alfalfa, beet, carrot, corn, cucumber, eggplant, onion, peach, and tomato.

**Particulate Matter:** Particulate matter such as cement dust, magnesium-lime dust and carbon soot deposited on vegetation can inhibit the normal respiration and photosynthesis mechanisms within the leaf. Cement dust may cause chlorosis and death of leaf tissue by the combination of a thick crust and alkaline toxicity produced in wet weather. Accumulation of alkaline dusts in the soil can increase soil pH to levels adverse to crop growth.

**Methane:** Methane or natural gas is a greenhouse gas. It is 20 times more potent than carbon dioxide ( $\text{CO}_2$ ) over a century, and researchers have repeatedly examined the contribution of natural gas emitted by ruminant cattle to global warming. The Scientists observed that any further rises in temperature are likely to accelerate the release of methane from rivers, lakes, deltas, bogs, swamps, marshlands and rice paddy fields. Most of the methane in freshwater systems is produced by an important microbes called *Archaea*, that live in waterlogged, oxygen-free sediments.

Microbes, algae, freshwater plants and animals are all part of an active ecosystem and take their nourishment from and return waste to the atmosphere. Healthy plants take  $\text{CO}_2$  from the atmosphere with photosynthesis. Plant uptake of  $\text{CO}_2$  is affected by temperature, and so is microbial methane production. Scientists are in view that the ratio of methane to  $\text{CO}_2$  also goes up with temperature, which is the same whether it is for the microbes or for the whole ecosystem. Methane fluxes are much more responsive to temperature than the processes that produce and consume carbon dioxide highlights another mechanism by which the global carbon cycle may serve to accelerate rather than mitigate future climate change.

### **Effect of Water and Land Pollution**

Water Pollution is the contamination of streams, lakes, underground water, bays, or oceans by substances harmful to living things. Water is one of the most essential things that pertain to life for all living things. Impure water kills plants and animals. It also causes humans to fall sick and acquire other illnesses like child-birth defects and cancer. Land pollution is similar to that of water. It is the contamination of land with hazardous waste like garbage and other waste materials that do not belong to the land. Plants and animals consume these and then when the next consumer feeds on either the plant or the animal, it plies up and contaminates the body.

Usually land water bodies get polluted by deposition of pollutant in the air. In addition the pollutants added in the land and/or soil through fertilizers, pesticides, herbicides, garbage and oil spills are deposited in the surface water bodies through run off and ground water through vertical movement of water inside the land mass, known as percolation. These pollutants affect soil directly changing its pH, structure, salinity and many more functions. Most of these are found detrimental to plant and aquatic animals and finally affect us through food chain.

It is well known that agriculture is the single largest user of freshwater resources, using a global average of 70%

of all surface water supplies. Except for water lost through evapotranspiration, agricultural water is recycled back to surface water and/or groundwater. However, agriculture is both cause and victim of water pollution. It is a cause through its discharge of pollutants and sediment to surface and/or groundwater, through net loss of soil by poor agricultural practices, and through salinization and water logging of irrigated land. It is a victim through use of wastewater and polluted surface and groundwater which contaminate crops and transmit disease to consumers and farm workers. Agriculture exists within a symbiosis of land and water and, as FAO (1990a) makes quite clear, “... appropriate steps must be taken to ensure that agricultural activities do not adversely affect water quality so that subsequent uses of water for different purposes are not impaired.”

**SUSTAINABLE AGRICULTURE**

As defined by FAO, sustainable development is the management and conservation of the natural resource base and the orientation of technological and institutional change in such a manner as to ensure the attainment and continued satisfaction of human needs for the present and future generations. Such sustainable development (in the agriculture, forestry and fisheries sectors) conserves land, water, plant and animal genetic resources, is environmentally non-degrading, technically appropriate, economically viable and socially acceptable.

**THE FRAMEWORK**

The charts (Fig.-5a and 5b) below will help in understanding and conceptualizing the framework.

(a)

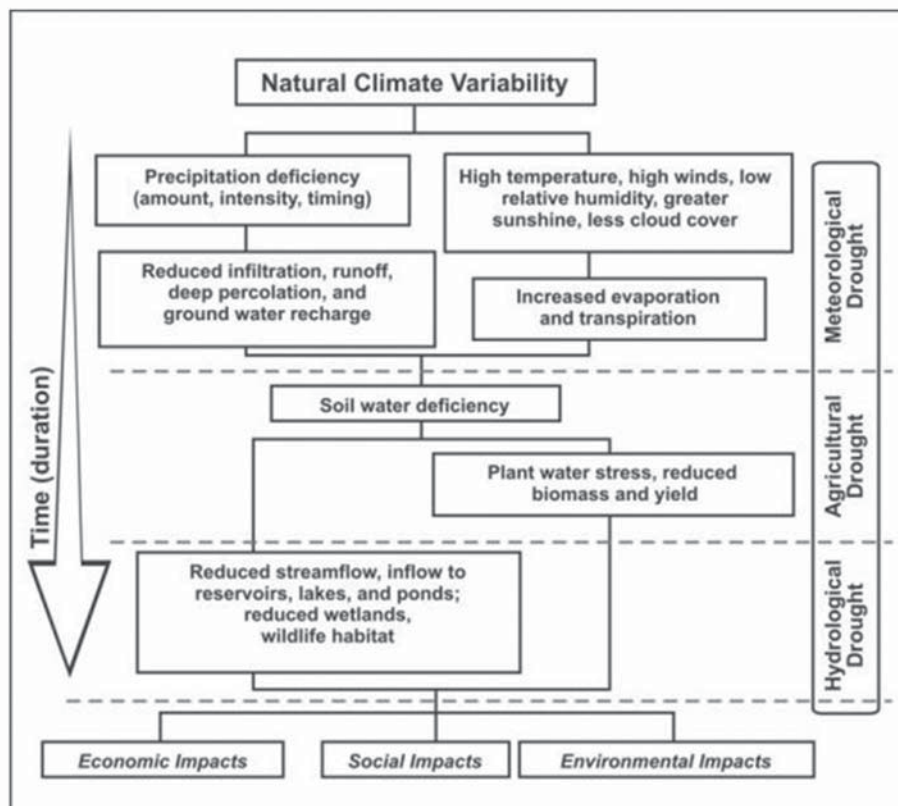

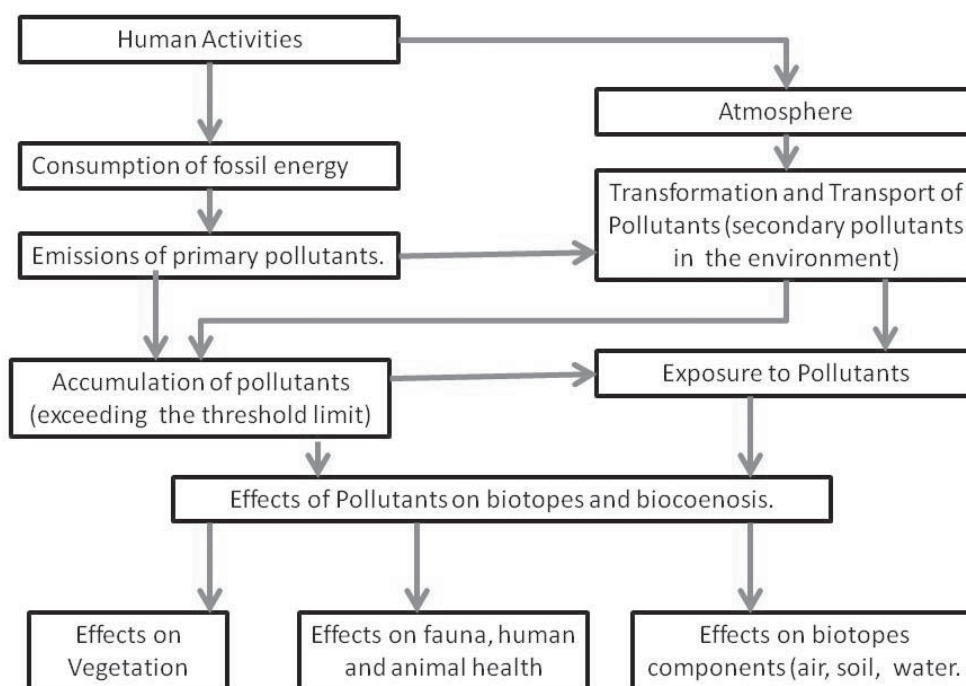

(b)

Fig.-5. Conceptual Framework

## WHAT IS TO BE UNDERSTOOD?

From the foregoing discussions it is clear that the most important climatic factors influencing growth, development and yield of crops are solar radiation, temperature and water and not less important is the function of land and soil. Each of these factors has been found to have limiting effects on various growth processes. However, these climatic factors always operate together and interact with each other under natural conditions. So, children, in particular, are to understand functions of all the factors in relation to crop growth, functions of soil and also the interaction of atmosphere, soil and plant.

### (A) Climatic Factors

#### Solar radiation

Of the solar radiation or electromagnetic spectrum, light is the visible portion. It is a form of kinetic energy that comes from the sun in tiny particles called *quanta* or *photons*, traveling in waves. Three properties of this climatic factor that affect plant growth and development are *light quality*, *light intensity*, and *day length* or *photoperiod*. Light quality refers to the specific wavelengths of light; light intensity is the degree of brightness that a plant receives; and day length is the duration of the day with respect to the night period.

Light is a climatic factor that is essential in the production of chlorophyll and in photosynthesis, the process by which plants manufacture food in the form of *sugar*(carbohydrate). Other plant processes that are enhanced or inhibited by this climatic factor include *stomatal movement*, *phototropism*, *photomorphogenesis*, *translocation*, *mineral absorption* and *abscission*. Any impedance or reduction on the availability of light will affect plant.

## Water

Water is an important climatic factor that affects or determines growth and development of plant. Its availability, or scarcity, can mean a successful harvest, or diminution in yield, or total failure. The importance of water relates to its essential functions in perpetuating both plant and animal life. It is an absolute requirement for all living organisms. But plant responses differ depending on plant species that belong to *mesophytes*, *hydrophytes*, or *xerophytes*. Nevertheless, water participates directly or indirectly in all metabolic processes in all living organisms. As a solvent, it also serves as a transport medium for mineral nutrients from the soil, as well as in the translocation of organic substances within the plant. It is a chemical reactant in photosynthesis and hence vital to life. It is also responsible for regulating temperature of plants through the process of transpiration. However, as with other climatic factors, water can also cause detrimental effects on plant growth and development. Excess water in the soil can injure flood prone plants like corn (Maize), due to lack of oxygen. In this case water stress due to flooding means oxygen stress by deficiency (hypoxia) or total absence (anoxia) of oxygen.

Rainfall is the most common form of precipitation and other forms of precipitation are freezing rain, sleet or ice pellets, snowfall, fog and hail. The amount and irregular occurrence of rainfall vary with location and climate types and affect crop growth and yield. So, occurrence of excess (flood) and deficit (drought) rainfall as an effect of climate change will affect crop yield drastically.

## Temperature

The degree of hotness or coldness of a substance is called **temperature**. This climatic factor influences all plant growth processes such as photosynthesis, respiration, transpiration, breaking of seed dormancy, seed germination, protein synthesis, and translocation. At high temperatures the translocation of photosynthate is faster so that plants tend to mature earlier. Moreover, due to prevalence of high temperature, plants try to complete its life-cycle by early flowering that causes yield loss.

In general, plants survive within a temperature range of 0 to 50°C. Enzyme activity and the rate of most chemical reactions generally increase with rise in temperature. Up to a certain point, there is doubling of enzymatic reaction with every 10 °C temperature increase. But at excessively high temperatures, denaturation of enzymes and other proteins occur. Conversely, excessive low temperatures also cause limiting effects on plant growth and development. For example, water absorption is inhibited when the soil temperature is low because water is more viscous at low temperatures and less mobile, and the protoplasm is less permeable. At temperatures below the freezing point of water, there is change in the form of water from liquid to solid. The expansion of water as it solidifies in living cells causes the rupture of the cell walls. Favorable or optimal day and night temperature range for plant growth and maximum yields varies among crop species.

Climatic condition	Day	Night
Cool	60-70°F (15.55-21.11°C)	50-55°F (10-12.77°C)
Intermediate	70-80°F (21.11-26.66°C)	55-65°F (12.77-18.33°C)
Warm	80-90°F (26.66-32.22°C)	65-70°F (18.33-21.11°C)

All plants have maximum, optimum and minimum temperature limits. The limits are cardinal temperature points. It is important to note that for growth and development and for maximum dry matter accumulation, an optimum



temperature is required. High night temperature affects growth of shoot. High temperature adversely affects not only mineral nutrition and shoot growth but also affects pollen development resulting in low yield. The critical temperature above which plants gets killed is called thermal 'death point' and temperature above 50°C may kill many annual crops. Soil temperature also influences crop growth regulating concentration of soil solution and its availability to the plants for nutrition. Soil surface temperature increases with the increase in atmospheric temperature, although it is regulated to a large extent by crop canopy.

### Cardinal Temperatures of Wheat and Rice

Wheat	3 – 4°C	Minimum
	25°C	Optimum
	30 - 32°C	Maximum
Rice	10 - 12°C	Minimum
	30 - 32°C	Optimum
	36 - 38°C	Maximum

### Low temperature Injuries

- Chilling injury** If the plants grown in hot temperature are exposed to low temperature, they will be killed or severely injured. When the night temperature is below 15°C field crops may show yellowing symptoms (e.g. Tropical annuals).
- Freezing injury** When the plants are exposed to how temperature, water freezes into ice crystals in the intercellular spaces (e.g. Cell dehydration) Temperate crops (potato, tea etc.,)
- Suffocation** Formation of thick cover of ice/snow on the soil surface presents the entry of oxygen and crop suffers. This presents the respiration and lead to accumulation of harmful substances.
- Heaving** Lifting of plants along with soil from its actual position by ice, crystals. This is a mechanical lifting.
- Frost damage** If the cell size is large the probability of frost damage is high due to Low temperature near the canopy resulting from earth's re-radiation.

### High Temperature Injuries

- Mineral Nutrition** High temperature stress causes reduction in absorption and subsequent assimilation of nutrients.
- Absorption of calcium is reduced at temperature (Example, at 28° C calcium absorption is reduced in Maize).
- Nutrient uptake is affected by both soil and air temperature in rice.
- Nitrate reductase activity decreases under high temperature.
- Shoot growth** High temperature, even for short period, affects crop growth especially in temperate crops like wheat.

	High air temperature reduces the growth of shoots and in turn reduces root growth.
	High soil temperature is more crucial as damage to the roots is severe resulting in substantial reduction in shoot growth.
	High temperature at 38° C in rice reduced plant height, root elongation and smaller roots.
<b>Pollen development</b>	High temperature during booting stage (stage between flowering and grain formation stages) results in pollen abortion.
	In wheat, temperature higher than 27° C caused under-development of anthers and loss of viability of pollen.
	A temperature of 30° C for two days at reduction division stage decreased grain yield by drastic reduction in grain set.
<b>Scorching</b>	High temperature lead to dehydration and leaves are scorched.
	High temperature causes injury on the exposed area of the plant (eg) Barks, it is known as 'Sun scald'
<b>Physiological activities</b>	High temperature disturbs the photosynthesis and respiration.
<b>Burning off</b>	Due to high soil temperature the seedlings are killed.
<b>Stem girdle</b>	High soil temperature causes stem scorches at the ground level (eg. in cotton).



*Stem girdle*

The **air** is a mixture of gases in the atmosphere; about 75% of air is found in the **troposphere**, the innermost layer of the atmosphere which extends about 17 km above sea level at the equator and about 8 km over the poles. In addition, about 99% of the clean, dry air in the troposphere consists of 78% nitrogen and 21% oxygen. The remainder consists of argon (slightly less than 1%), carbon dioxide (0.036%), and traces of other gases. Oxygen ( $O_2$ ) and carbon dioxide ( $CO_2$ ) in the air are of particular importance to the physiology of plants. Oxygen is essential in *respiration* for the production of energy that is utilized in various growth and development processes. Carbon dioxide ( $CO_2$ ) is a raw material in photosynthesis.

The air also contains water vapour ( $H_2O$ ), suspended particles of dust and chemical air pollutants such as carbon monoxide ( $CO$ ), carbon dioxide ( $CO_2$ ), sulfur dioxide ( $SO_2$ ), sulfur trioxide ( $SO_3$ ), nitrogen oxides, methane ( $CH_4$ ), propane, chlorofluorocarbons (CFCs), solid particles of dust, soot, asbestos and lead, ozone and many more. However,

the composition of this climatic factor is susceptible of variation.

Air within the soil is also very important as it is used by roots of the plants and animals living underground for their respiration. Any change in the composition of stratospheric air due to climate change will affect quality of soil air too.

#### Plant Health

*“For each carbon dioxide molecule that is incorporated into plants through photosynthesis, plants lose about 200 molecules of water through their stomata. Elevated CO<sub>2</sub> reduces the stomatal density in leaves, this is at first sight beneficial for plants, as they would lose less water. However, the reduction in the number of stomatal pores decreases the ability of plants to cool their leaves during a heat wave via water evaporation. Less evaporation adds to heat stress in plants, which ultimately affects crop yield.”*

*“This change causes leaf temperature to rise because of a decrease in the plant’s evapotranspirative cooling ability, while simultaneously increasing the transpiration efficiency of plants,” the report says. “These phenomena, combined with the increasing scarcity of fresh water for agriculture, are predicted to dramatically impact on plant health.”*

*-Julian Schroeder, professor of biological sciences  
at the University of California San Diego,  
who led the team that reports in Nature journal.*

### Humidity

The amount of water vapor that the air can hold depends on its temperature; warm air has the capacity to hold more water vapor than cold air. There is almost one-half reduction in the amount of water vapor that the air can hold for every 10°C drop in temperature.

**But, we are concerned mostly with Relative humidity (RH), which** is the amount of water vapor in the air, expressed as the proportion (in percent) of the maximum amount of water vapor it can hold at certain temperature. For example, an air having a relative humidity of 60% at 27°C temperature means that every kilogram of the air contains 60% of the maximum amount of water that it can hold at that particular temperature.

The amount of water vapor in the air ranges from 0.01% by volume at the frigid poles to 5% in the humid tropics. In relation to each other, high RH means that the air is *moist* while air with minimal content of moisture is described as *dry* air. Compared to dry air, moist air has a higher relative humidity with relatively large amounts of water vapor per unit volume of air. The relative humidity affects the opening and closing of the stomata, which regulates loss of water from the plant through transpiration as well as photosynthesis. The amount of humidity in air influences incidence of pest and diseases in plants resulting severe yield loss.

### Wind

**The** air movement, termed as **wind**, is due to the existence of pressure gradient on a global or local scale caused by differences in heating. On a global scale it consists of the jet stream flow and movement of large air masses. On

the local scale only a smaller quantity of air moves. Surface winds are lower and less turbulent at night due to the absence of solar heating.

When air is close to the ground it cools, and subsequently it contracts and the pressure rises; when it warms, it expands and pressure drops. Where both cold and warm air occur in proximity, as over a lake and its adjacent shore, the cold flows to the direction of the warm air or from high to low pressure area to correct the pressure imbalance. This also happens in tropical Asia but in a larger and more complex way, as the *monsoon* winds. Moderate winds favor gas exchanges, but strong winds can cause excessive water loss through transpiration as well as lodging or toppling of plants. When transpiration rate exceeds that of water absorption, partial or complete closure of the stomata may ensue which will restrict the diffusion of carbon dioxide into the leaves. As a result, there will be a decrease in the rate of photosynthesis, growth and yield. This climatic factor serves as a vector of pollen from one flower to another thus aiding in the process of pollination. It is, therefore, essential in the development of fruit and seed from wind-pollinated flowers as in many grasses.

### (A) Function of Soil

Soil performs multiple functions starting from providing physical, chemical and biological support for plant growth. It provides habitat for variety of flora and fauna including human. Lives. It acts as natural filter and buffer media against abrupt changes occurring in it. It also acts as a sink of organic carbon and thus global CO<sub>2</sub> flux.

The upper thin layer (usually 15 cm depth) of land surface is the most favourable medium for plant growth. Plant anchors and draws nutrients and water from this layer. Soil in this layer performs a number of ecosystem services like storage, decomposition, transformation, and detoxification and thereby provides right soil condition for crop/plant growth. Numbers of biogeochemical cycles like carbon, nitrogen, phosphorus and sulfur cycles are being operated and nutrients are being released for plant and soil organisms and thus biomass production are sustained in the earth.

### (B) Atmosphere-Soil-plant System

It is to be very much clear to the children that all the component of the earth system i.e. atmosphere, lithosphere, hydrosphere and biosphere are interdependent and act by the influence of solar energy (Fig.-3). Moreover, nature maintains a balance among them. So any change at any level may lead to the catastrophe to the crop production system vis-à-vis the agriculture as a whole.

It has further been explained through figure-4 that there is strong relationship between physical climate system and biogeochemical system.

So, under this sub-theme, children can observe changes in the weather regulating factors and their impact on agricultural system in their own area and find out some method/technique to mitigate. Moreover, there are many practices related with seed selection, irrigation, soil management etc., which can help in adaptation process.

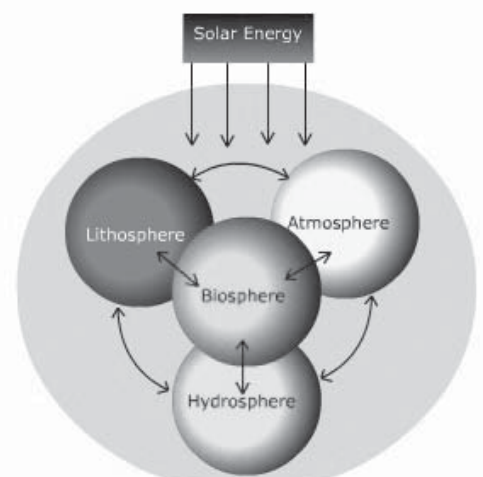
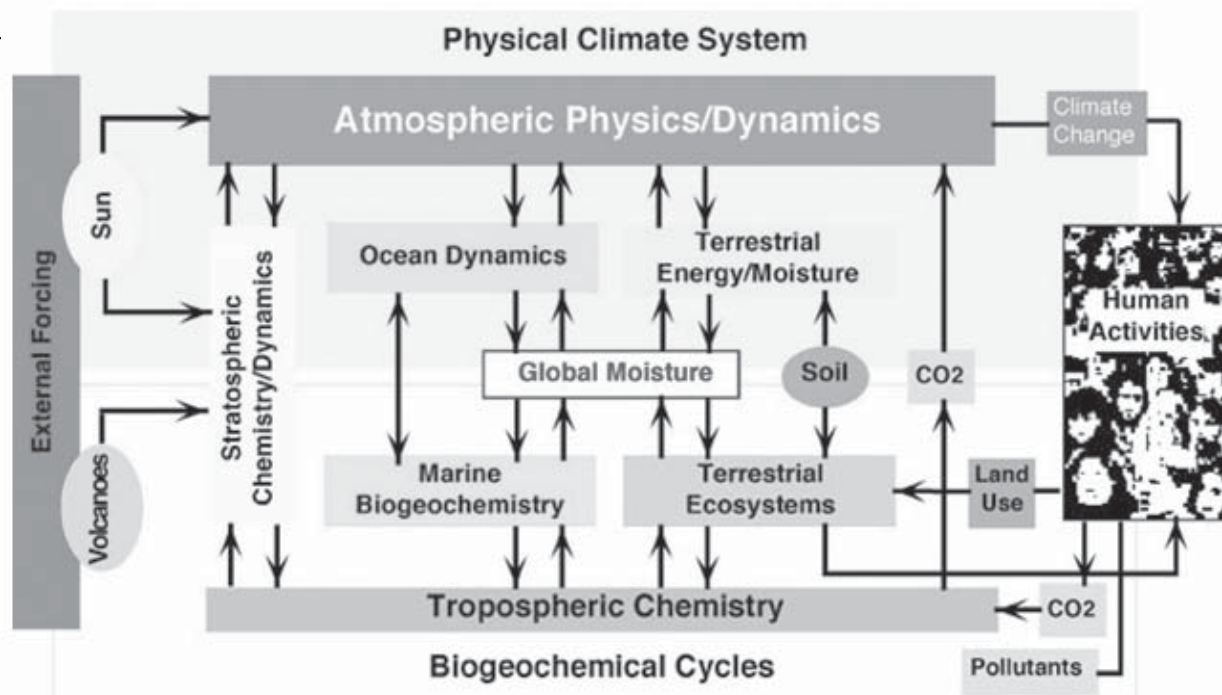

Fig.-3. The Earth System

Fig.



from *Earth System Science: An Overview*, NASA, 1988

## PROJECT IDEAS

### Project 1: Conservation agriculture for sustainable land use

#### Introduction:

Conservation agriculture is application of modern agricultural technologies to improve production with concurrent protection and enhance the land resources on which the production depends. It promotes the concept of optimizing yield and profits with minimal disturbance of land resources along with balanced application of chemical inputs and careful management of crop residues and waste.

#### Objectives

- To promote minimal mechanical disturbance of soil through zero/minimum tillage.
- To maintain permanent soil cover with available crop residues and other wastes.
- Efficient nutrient management practices through balanced application of organic and inorganic source.
- Effective utilization of residual soil moisture.

#### Methodology

1. Selection of field
2. Selection of crop (Cereals/Oilseed/Pulse/ leafy vegetables)
3. Divide the field into two equal halves and mark as (a) and (b)
  - a) Dig lines of 2" – 3" depths with equal distance between the lines, place the fertilizer, cover it with loose soil, place the seed on it and cover the lines.
  - b) Plough the soil and apply fertilizer (as per local practice) and sow the seeds.
4. Doses of fertilizer, pesticides etc. will be as per practice followed by farmers.

**Observation:**

1. Record economic yield/ biomass data of the crops
2. Workout the economic benefit.
3. Determine bulk density of soil at the time of harvest of the crops from all the plots.
4. Find out porosity of soil and compare the differences.

**Procedure to measure bulk density:**

- 1) Cut 4-6" length pieces (core) from a G I Pipe with > 2" diameter
- 2) Place the core on the soil surface.
- 3) Place a wooden block (approximately 4" width, 5" length, 1" thickness) on the top of the core.
- 4) Hammer the wooden block to push the core into the soil
- 5) Cut the soil around the core with spade and take out the core with soil in it.
- 6) Cut the excess soil at both ends of the core with knife so that volume of the core will represent volume of the soil
- 7) Take the weight of core plus soil
- 8) Push the soil out, wash and clean the core and make it dry.
- 9) Take the weight of the core
- 10) Measure the inside diameter and length of the core, which will be used in calculating the volume of soil
- 11) Divide the mass of the soil by the volume of soil this will give the bulk density of the soil.

**Follow up:**

- 1) Show the crops condition to others.
- 2) Discuss the results with the farmers/ students.

**Note:**

Density is the mass of an object per unit volume. It is expressed as gm/cm<sup>3</sup>

Soil has got two densities – Particle density and Bulk density.

- **Particle density (pd)** is the density of the solid soil particles (sand, silt and clay). For all practical purposes and on-farm studies average particle density is considered as **2.65 gm/cm<sup>3</sup>**
- **Bulk density (bd)** is the density for a volume of soil as it exists naturally, which includes any air space and organic materials in the soil volume. Science bulk density is calculated for the dried soil, moisture is not included in the sample. It is calculated using the following formula

**bd = weight of soil/ volume of soil core**

**Volume of soil core =  $\pi r^2 h$**  ( $\pi = 22/7 = 3.14$ )

Where, 'r' is the radius of the core = **d/2** (d is the diameter of the core)

'h' is the height of the soil core

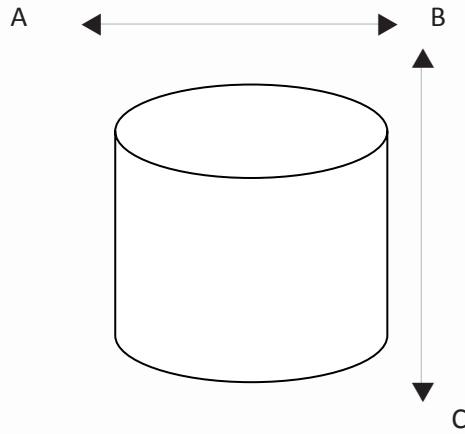

Suppose, in the figure of the cylinder, AB is the diameter ( $d$ ) and  $AB/2$  or  $d/2$  is the radius ( $r$ ). BC is the height ( $h$ ) of the cylinder.

- Calculate
- (i) cross sectional area( $A$ ) of the cylinder ( $A = \pi r^2$  )
  - (ii) Volume of the cylinder ( $V = A \times h = \pi r^2 \times h = 3.14r^2 \times h$  ( $\pi = 3.14$ ))

$$\text{Soil porosity, \%} = (1 - bd/2.65) \times 100$$

## **Project 2: Mitigate soil and water loss through runoff with suitable control measures.**

### **Introduction:**

Land degradation refers to the loss of inherent capacity of land to produce healthy and nutritious crops. It may occur with various forms – physical, chemical and biological. Soil erosion is the most important forms of land degradation as the vast area of our country suffers due to such process. It is, therefore, necessary to protect this shrinking valuable land resource to meet the demand of ever increasing population. Some of the common measures are practiced for preventing the loss of runoff water and soil particles from the sloppy land, which includes terracing, bunding, cover cropping, strip cropping, conservation tillage, cultivation along or across the slope etc.

### **Objectives:**

- 1) Quantify loss of soil and water through runoff.
- 2) Implement control measure to check the loss of soil and water.
- 3) Sustainable land use practice in areas prone to erosion.

### **Methodology:**

- 1) Selection of a suitable sloppy land.
- 2) Divide the land into at least 3 parts along with the slope.  
(Minimum width of each part shall be 3m)
- 3) a) Keep fallow or undisturbed.  
b) Grow cover crops.

- c) Grow strip crop as per local practice.
- 4) Separate the adjoining parts by erecting suitable barriers with non porous inert materials
- 5) Place suitable notch at the middle part of the lower end through which runoff water and soil particle will pass.
- 6) Place a large bucket or suitable tank to collect the run off water and soil particles.

### How to calculate slope of a land?

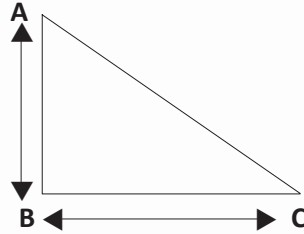

Suppose BC is the length of a land and AB is the height of the land;

$$\text{So, Slope \%} = (\text{BC} / \text{AB}) \times 100$$

### Observation:

- 1) Length of slope
- 2) Percent of slope
- 3) Amount of water added at the upper end to initiate the runoff process
- 4) Measure the amount of water and soil collected in the tanks at lower end.

### Follow-up:

- 1) Transfer the results of the experiments to the farmers and local people.
- 2) Demonstrate the experiment to students of the area.

### GLOSSARY

**Acid rain:** rain having a pH lower than 5.6 (the pH of natural rainwater), usually caused by sulfuric acid and/or nitric acid from air pollution.

**Atmosphere:** air enveloping earth due to earth's gravitational pull. Can be divided into layers radiating out from the surface in the following order- troposphere, stratosphere, mesosphere, thermosphere.

**Biosphere:** the zone between the earth and the atmosphere in which most life forms reside.

**carbonsequestration:** The uptake and storage of carbon in a carbon sink, such as the oceans, or a terrestrial sink such as forests or soils, in order to keep the carbon out of the atmosphere.

**Climatology:** scientific study of the climate, the causes of a climate, and the use of data to solve climate related problems.

**Degree-day unit:** a measure of how much the mean daily temperature differs from a base temperature in Fahrenheit and Celsius. Used to determine how much fuel will be needed to heat or cool indoor environments.

**Desalination:** The process of removing salts from water, usually seawater, soil, or other substances.



**Desertification:** when an area begins to develop desert-like conditions due to lack of water, deforestation, overgrazing and over cropping.

**Dew:** when liquid water from the atmosphere condenses on plants and objects near the ground.

**Diurnal:** referring to daily phenomena.

**Drought:** a long period of time where there is abnormally dry weather due to little or no precipitation.

**El Niño :** warming of ocean waters in the eastern tropical pacific, resulting in warmer waters off the coasts of Ecuador and northern Peru. Associated with heavy rainfall in those regions, and also affects weather patterns in North America as well. Usually begins to occur around Christmas, and is so named for El Niño, the Spanish name for the Christ Child.

**Erosion:** when rock and soil are moved from one place to another by running water, precipitation, ice, or wind.

**Evaporation:** the change of state from a liquid to a vapor.

**Evapotranspiration:** the combined water vapor put into the air through evaporation from water on earth's surface and plants giving off water to the atmosphere.

**Flood:** when water overflows the confines of a body of water and gathers over low-lying areas.

**Fog:** a visible gathering of water droplets suspended in the air near the earth's surface.

**Greenhouse gas:** gases in the atmosphere that are more transparent to the short wavelength radiation (mostly visible light) from the sun, than to the long wavelength radiation (infrared radiation) leaving the Earth. These gases then reemit the trapped energy, partly toward the Earth's surface. Examples are carbon dioxide, methane, CFCs, and nitrous oxides.

**Greenhouse effect:** a natural occurrence caused by certain greenhouse gases in the Earth's atmosphere. Because greenhouse gases trap longwave energy and reemit it back to the Earth's surface, the global temperature is changed 33 degrees Celsius, or 59 degrees Fahrenheit warmer than it would otherwise be. Some scientists think that the increase in greenhouse gases in the atmosphere (caused by pollution- mainly the burning of fossil fuels and deforestation) may be causing a rise in global temperature.

**Humidity:** the measure of how much water there is in the air.

**Hydrologic cycle:** the exchange of water between the earth, the oceans, and the atmosphere. Also called the water cycle.

**Hydroponics:** It's a method of growing plants using mineral nutrient solutions, in water, without soil.

**Hydrosphere:** the part of planet earth that is covered with water and ice.

**Isobar:** a line of equal pressure resembling a contour line on a map.

**Isotherm:** a line passing through points of equal temperature on a map.

**La Niña:** a period of strong trade winds and abnormally low sea surface temperatures in the central and eastern tropical Pacific. It is the opposite of an El Niño. Spanish for little girl child.

**Lithosphere:** the outer solid portion of the planet earth, made up of the earth's crust and upper mantle. All the rock on earth.

**Meteorology:** study of the phenomena of the atmosphere. Includes physics, chemistry and dynamics of the atmosphere as well as the direct effects upon the earth's surface, oceans and life in general. Oriented towards developing a complete understanding, accurate prediction, and artificial control of atmospheric occurrences.

**Monsoon:** when the principal wind direction changes noticeably with the season. The main cause is the heating and cooling of a nearby ocean depending on summer and winter, such as the Indian Ocean and the India monsoon for example.

**Ozone layer:** a place in the stratosphere (about 10-50 kilometers up) where the high ozone (O<sub>3</sub> molecules) concentration shields the Earth from harmful ultraviolet radiation.

**pH scale:** a measure of the range of acidity and alkalinity of a substance, on a scale from 0-14, with acids being on the lower end and bases on the higher end. A value of 7 is neutral.

**Precipitation:** any form of water particles that fall from the clouds and reach the ground. Examples are rain, snow, sleet, and hail. Fog, dew, frost, and clouds are not forms of precipitation.

**Relative humidity:** ratio of the actual vapor pressure of the air to the saturation vapor pressure for the surrounding air temperature. In other words, how much water the air is holding divided by how much water the air is capable of holding.

**Soil environment:** A condition of the soil, whether physical, biological or chemical, that influences the organisms and processes that occur in the soil.

**Soil organic carbon:** That portion of non-living organic compounds in the top one meter of soil, e.g. humus, which is important to soil quality and plant nutrition and is replenished by the decomposition of plant material.

**Soil remediation:** The removal of contaminants and pollutants from soil.

**soil water regimes:** The presence or absence either of ground water or of plant available water (i.e., water held at a tension of less than 1500 kPa) in the soil or in specific horizons during periods of the year. A generally accepted classification of soil moisture regimes from wet to dry includes aquic, udic, ustic, aridic, and xeric.

**Ultraviolet radiation:** electromagnetic radiation with wavelengths ranging from 1-300 nanometers. Can be divided into three types-UVA (responsible for tanning the skin and some types of skin cancers), UVB (responsible for sunburn and skin cancers), and UVC (potentially lethal radiation, but does not reach the earth's surface because of protection from the ozone layer).



*Sub Theme 6*

**WEATHER, CLIMATE  
& HEALTH**



# Weather, Climate and Health

## 1. Background

Climate implies meteorological weather conditions including wind, temperature, precipitation, snow, and clouds that characteristically prevail in a particular region, calculated by averaging these weather conditions over an extended period, usually at least 30 years. Weather describes a phenomenon that can change quickly from hour to hour, day to day, season to season and year to year at a given location or region, even within an unchanging climate.

Weather and climate influences environmental and social determinants, and in addition, it affect health of the

living beings. Health is a state of complete physical, mental, and social well being and not merely absence of disease. Public health depends on availability of enough food, safe drinking water, a decent home protection against disasters, a reasonable income and good social and community relations (WHO, 2003). Weather and climate, thus, have direct and indirect relationship on human and animal health.

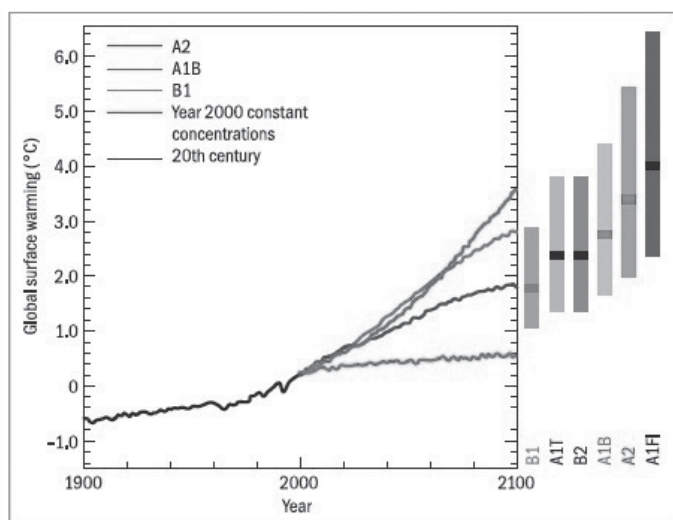

Global average warming relative to 2000 and projected to 2100 for three IPCC scenarios

Note Vertical bars on the right show best estimates and ranges for six emission scenarios for 2100

Source IPCC Fourth Assessment Report

of direct exposures (e.g., extreme heat), indirect exposures (e.g., changes in water, air, and food quality), and social and economic disruptions. Thus, climate change produces a dynamic system where a change in one condition exerts influence in multiple pathways with associated health consequences (Michael *et al.*, 2012).

Climate change studies have shown that heat waves and higher temperatures can lead to an increase in serious air pollution that may cause respiratory, cardiovascular and cancerous diseases to people living in the urban and industrial zones. Heavy rainfall, floods, or droughts occurring frequently are threatening global safety, drinking water supply and food security leading to an increase in malnutrition, hunger, and famine.

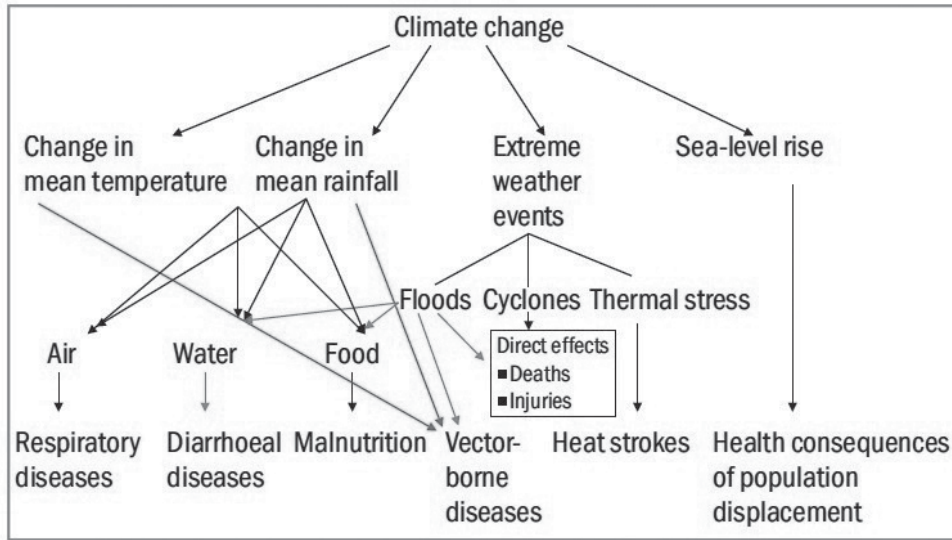

Dogra–Srivastava Framework for Climate Change and Health Outcomes

The changes in environmental temperature, air humidity, and rainfall patterns are increasing the sensitive of vector-borne diseases such as malaria, dengue, chikungunya, Lyme disease, Japanese encephalitis, diarrhea, kala-azar, filariasis and cholera and the likes. In addition, natural disasters and abnormal weather phenomena can cause chronic stress disorders and many other psychological or mental health

problems. Sea level rise resulting into the land loss, infrastructure damage, and a reduction in farming productivity may lead to increasing forced migration and several other socio-economic problems. Climate change also affects infrastructure of public health care systems (Bush *et al.*, 2011; Tuan, 2013).

Relationships between year-to-year variations in climate and infectious diseases are most evident where climate variations are marked, and in vulnerable populations. Elder people, children, economically weaker, and especially women living in the undeveloped areas are the most vulnerable and sensitive to climate change. The El Niño phenomenon provides an analogue for understanding the future impacts of global climate change on infectious diseases.

Climate change will have a wide variety of health impacts, many are predictable, but some are not. Higher maximum temperatures will lead to increased heat-related deaths and illnesses and contribute to an extended range of some pest and disease vectors. In some areas, there will be increased severity and frequency of droughts leading to forest fires; in other areas, more intense rainfall will lead to slope instability, flooding and contaminated water supplies. More intense, large-scale cyclones will increase the risk of infectious disease epidemics (e.g., via damaging water supplies and sewerage systems) and cause the erosion of low-lying and coastal land through storm surges. Indirect effects of climate change will occur from economic instability, loss of livelihoods and forced migrations.

In light of the fact, that weather and climate have potential impact on the health of human beings and animals, child scientists are expected to understand the causative factors, the concerns arising and the corrective measures that can be adopted to lessen the adversity. Ailments like vector-borne diseases, infections and infestations, water and / air borne diseases, zoonosis, emergence and reemergence of certain diseases which are influenced by the variability of weather and climate are some of the areas to ponder upon and take up the study.

**Figure.** Potential Health Effects of Climate Variability and Change

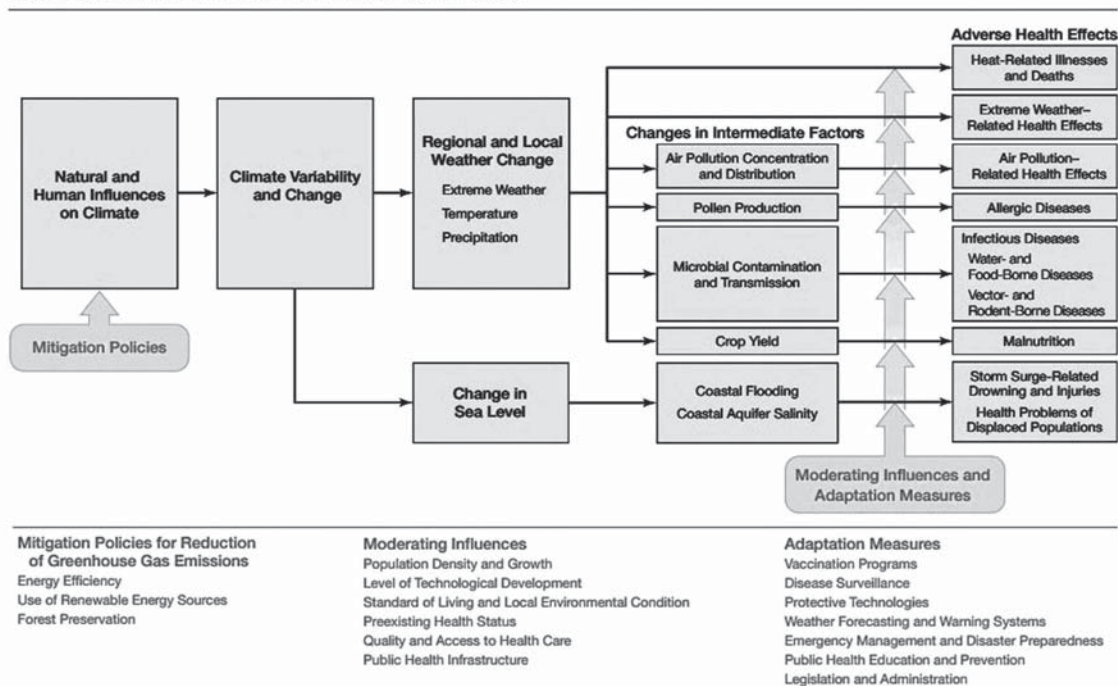

Adapted from Patz et al.<sup>2</sup> Schematic of pathways through which climate change can affect multiple health outcomes. Examples are also given of moderating factors and adaptive measures determining extent of adverse outcomes, as well as mitigating measures to prevent global warming.

## 2. Framework

### a. What is to be understood?

**Weather and Climate:** India has a unique climatic regime with two monsoon seasons (south-west and north-east), two cyclone seasons (pre- and post-monsoon), hot weather season characterized by severe thunderstorms and heat waves, and cold weather season characterized by violent snowstorms in the Himalayan regions and cold waves. Heavy to very heavy rainfall during the monsoon season (June–September) often cause floods over many parts of India. Similarly, strong winds, heavy torrential rains, storm surges and astronomical tides associated with tropical cyclone are also prevalent over the coastal belt of India mainly during the pre-monsoon (April–May), early monsoon (June), and post-monsoon (September– November) periods. These disasters often result in epidemics.

**Health:** Weather and climate have both direct as well as indirect bearing on human and animal health. Climate disasters such as floods and droughts affect health and lead to social and economic disruption. They, more often than not, directly result in mortality and morbidity and may indirectly lead to an increase in the transmission of communicable diseases as well as damages to local infrastructure, displacement of population and ecological change. The majority of disasters occur in regions where infectious diseases such as malaria and dengue are either endemic or have a high endemic potential. Presumably, the impact of communicable diseases is often very high in the aftermath of disasters. However, the increase in endemic diseases and the risk of outbreaks are rather dependent on other different factors also, such as population movement and water as well as sanitation facilities that work synergistically to increase mortality resulting from communicable diseases.

**Relationships:** Extreme conditions such as heat wave and cold wave, drought and flood, storms and strong winds, have a greater impact on health of animals and human beings. The current burden of disease due to climate sensitive

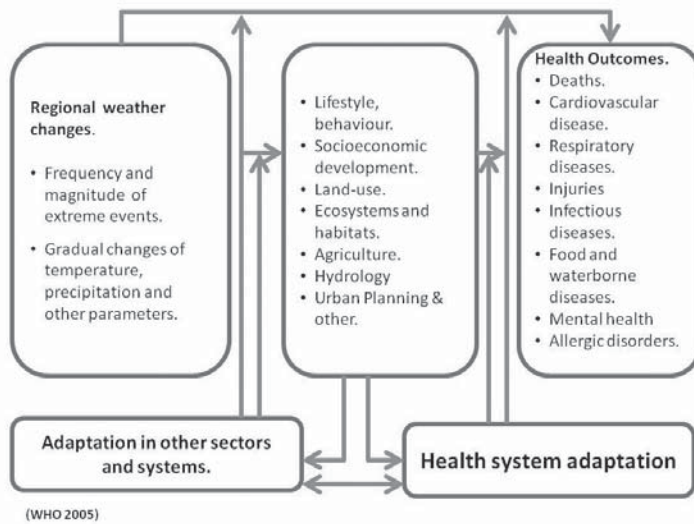

health outcomes, including but not limited to diarrhoea, vector-borne diseases, malnutrition, deaths due to floods and landslides, and cardiovascular diseases in cold waves and heat waves, is considerable.

During summer, most regions in India experience episodes of heat waves every year causing sunstroke, dehydration, and death. An analysis of daily climatological heat index (HI; combining temperature and humidity) over 41 districts well distributed over the country indicated that maximum HI exceeding 45°C characterizes many districts during March to May and June to September. On the other hand, the wind

chill index (combining temperature and wind speed) is less than 10°C for a very few districts in northern India mainly in winter (January–February) and the post monsoon season (October–December). Different climatic conditions create favourable conditions for the transmission of vector-borne and enteric diseases.

## b. Why is it important?

The potential health impacts of climate change are immense and managing the health impacts thereby is an enormous challenge. It is widely acknowledged that climate change is only one of many important factors influencing the incidence of infectious diseases and their effects are very unlikely to be independent of socio-demographic factors (e.g., human migrations, transportation, nutrition), or of environmental influences (e.g., deforestation, agricultural development, water projects, urbanization).

Extreme high air temperatures contribute directly to deaths from cardiovascular and respiratory disease, particularly among elderly people. Urban air pollution causes millions of deaths every year. Pollen and other aeroallergen levels also increase triggering asthmatic bouts (WHO, 2014). A report from the Ministry of Health and Family Welfare estimates that waterborne diseases affect nearly 40 million people, every year (Mandal, 2008). The summer of 2010 was one of the hottest summers on record in India, with temperatures approaching 50°C (122°F); the effects were far-reaching, including hospitalization because of heatstroke, suffering of livestock, and severe drought in some regions that affected health as well as agriculture (Burke 2010). India has approximately 2 million confirmed cases of malaria every year (Kumar et al. 2007). Like most infectious diseases, prevalence however varies by region. WHO concludes that approximately 15,000 individuals die from malaria each year in India (WHO 2008). A study by Dhingra et al. (2010) estimates approximately 200,000 malaria deaths per year in India before 70 years of age and 55,000 in early childhood.

## 1. Patterns of infections

Climatic conditions strongly affect water-borne diseases. Changes in climate are likely to lengthen the transmission seasons of important vector-borne diseases and alter their geographic range.

Malaria is a climate-sensitive disease transmitted by Anopheles mosquito. The distribution map of India reveals Odisha, northeastern states, Jharkhand and Chhattisgarh as endemic with stable malaria while Rajasthan, Uttar Pradesh, Himachal Pradesh, and Uttarakhand with unstable malaria. In stable malaria, transmission continues almost



throughout the year as the temperature, rainfall and resultant relative humidity are suitable for round the year. The states having unstable malaria experience winters during which transmission does not take place. Areas with unstable malaria are epidemic prone depending on favorable conditions provided by unusual high rains at the threshold of the transmission season. Distribution of malaria and its endemicity is the reflection of suitable climatic conditions and availability of mosquito vectors in different parts of the country (INCCA, 2010).

Dengue, primarily transmitted by *Aedes aegypti* and secondarily by *Aedes albopictus*, is a major public health concern for over half of the world's population and is a leading cause of hospitalization and death, particularly for children in endemic countries. Rise in temperature is potentially associated with substantial increase in dengue outbreaks. Apart from climate factors other important issues that potentially contribute to global changes in dengue incidence and distribution include population growth, urbanization, lack of sanitation, increased human travel, ineffective mosquito control, and increased reporting capacity ((Naishet *et al.*, 2014) .

## 2. Loss of life

**Water-borne infectious diseases:** A report from the Ministry of Health and Family Welfare estimates that water-borne diseases affect nearly 40 million people every year burdening both the health and the economic sectors.

**Vector-borne disease:** India has approximately 2 million confirmed cases of malaria per year (Kumar *et al.* 2007). A study by Dhingra *et al.* (2010) estimates approximately 200,000 malaria deaths per year in India before 70 years of age and 55,000 in early childhood.

**Heat stress:** In recent past, the summer of 2010 was one of the hottest summers on record in India, with temperatures approaching 50°C (122°F); the effects were far-reaching, including hospitalization because of heat stroke, suffering of livestock, and severe drought in some regions that affected health as well as agriculture (Burke 2010).

**Floods:** Floods contaminate freshwater supplies, heighten the risk of water-borne diseases, and create breeding grounds for disease-carrying insects such as mosquitoes. Floods have been increasing in occurrence and intensity. Extreme weather events such as floods cause water logging and contamination, which in turn exacerbate diarrheal diseases such as cholera, vector-borne diseases, malnutrition, and deaths.

## 3. Adaptations and mitigations

Potential adaptation strategies in India could focus on controlling infectious diseases by removing vector-breeding sites, reducing vector-human contact via improved housing, and coordinating monitoring of mosquitoes, pathogens, and disease burden. In addition, improving sanitation and drinking water by supporting inexpensive and effective water treatment and increasing rainwater harvesting, safe storage, and gray-water reuse could be other means. In some areas, the focus may shift to flood, heat wave, and emergency preparedness, including strategies to address the additional risks placed on displaced populations from these and other climate-sensitive hazards. Developing an integrated early warning system, emergency response plans, and refugee management plans, along with increased capacity to provide shelter, drinking water, sanitation, and sustainable agricultural products to the most vulnerable populations could be the outcome (Bush *et al.*, 2011).

**Environmental monitoring and surveillance:** There is a great need to improve environmental monitoring and surveillance systems in countries such as India. New research initiatives should focus on collecting high quality,

long-term data on climate-related health outcomes with the dual purpose of understanding current climate–health associations and predicting future scenarios. Health outcomes of interest, for which such data should be collected, include total morbidity and mortality and non-communicable diseases such as cardiovascular and respiratory diseases including asthma, as well as infectious diseases such as cholera, malaria, tuberculosis, typhoid, hepatitis, dysentery, tick-borne encephalitis, and other vector-borne and water-borne diseases. Such monitoring also requires the collection of appropriate climatic (e.g., temperature and precipitation) and non-climatic data (e.g., ozone). Surveillance of extreme weather conditions and risk indicators such as mosquito abundance or pathogen load is also necessary. Such data gathering should occur in conjunction with already existing public health programs and health centers. Where the necessary public health infrastructure does not exist, the anticipated risks associated with climate change should motivate international action to build such infrastructure. The collection of such diverse data necessitates the creation of linkable and documented repositories for meteorological, air pollution, and health data (Bush *et al.*, 2011).

### **c. How to go about?**

**i. Identify vulnerable areas and groups:** All populations will be affected by climate change, but some are more vulnerable than others. People living in small islands, developing states and other coastal regions, megacities, mountainous regions are particularly vulnerable. Vulnerability of a population depends on factors such as population density, level of economic development, food availability, income level and distribution, local environmental conditions, pre-existing health status, and the quality and availability of public health care.

**ii. Identify health risks:** Climate-sensitive health risks include those occurring as a direct consequence of exposure to climatic stimuli (heat stroke, drowning during flood), those mediated via climate-sensitive ecological systems (water-borne and vector-borne diseases) and those resulting from the wider social implications of climate change (malnutrition). Children in particular are among the most vulnerable groups to the resulting health risks and will be exposed longer to the health consequences. The health effects are also expected to be more severe for elderly people and people with infirmities or pre-existing medical conditions. Appropriately managed resources and infrastructure could further help tackle the health risks of climate change as well as reduce greenhouse gas emissions. Similarly, a suitable lifestyle including appropriate dietary habits could not only further reduce the risks of non-communicable diseases but also contribute to protecting the climate.

A Case Study of Malaria in India presents an assessment on health risks due to climate change in India, especially enhanced malarial incidences. All-India rainfall in October seems to be positively correlated with malaria incidences in the following year whereas the May rainfall is negatively correlated with malaria incidences. Also cold temperature anomalies over eastern Pacific south of equator March-April-May season seems to be favorable for malaria incidences over India as this is also favourable to subsequent good summer monsoon rainfall.

**iii. Control measures for food and water-borne, and vector-borne diseases:** The main parameters affecting vector-borne diseases include temperature, rainfall, and absolute humidity. Malaria mitigation strategies require a combination of preventive and curative treatment methods and close collaboration between the health and climate sectors. The timely provision of climate information with several months lead-time can be combined with a well-developed national and regional response strategy that allocates resources for public outreach and distribution of

medication and insecticides well in advance.

Warmer temperatures and increased rainfall variability are likely to increase food-borne and water-borne diseases. Infectious agents, such as protozoa, bacteria and viruses, and vector organisms, such as mosquitoes, ticks and sand flies, have no thermostatic mechanisms, so reproduction and survival rates are strongly affected by temperature levels and fluctuations.

The combination of warmer temperatures and increased rainfall variability is likely to increase the intensity and frequency of food-borne and water-borne diseases. Several studies have found relationships between temperature and food poisoning, as well as between temperature and specific enteric diseases (Bentham & Langford 2001, Kovats et al. 2005, Hashizume et al. 2007).

	Effect
1	Morbidity and mortality associated with extreme coastal events such as flooding, cyclones, and storm surges
2	Effects on nutrition due to loss of agricultural land or decline in fish catch
3	Reduced freshwater availability by saltwater intrusion into groundwater aquifers
4	Changes in distribution of disease agents
5	Psychological trauma and stress
6	Population displacement associated with loss of land or other socio-economic and health impacts
7	Impacts on "sensitive" coastal ecosystems and loss of coastal livelihoods

**iv. Infrastructure facilities to face natural disasters:** Natural disasters have a variety of health impacts. These range from immediate effects of physical injury and morbidity and mortality through to potentially long lasting effects on mental health status. Most flood-related deaths can be attributed to rapid rise of water level, resulting in increased risk of drowning. Following floods increase in diarrheal and respiratory diseases are reported. Disease transmission is increased where there is crowding of displaced populations.

**v. Sea level rise:** In light of climate change, extreme coastal events and accelerated sea level rise can threaten human safety and shoreline development. The coastal system is extremely

dynamic owing to the changing nature of interactions between its components—the natural and human systems. Nearly a quarter of India's population living along its 7500 km coastline is at high risk due to sea level rise and its associated impacts. In India, model simulation studies indicate that SLR related to thermal expansion is expected to be between 15 cm and 38 cm by the middle of this century and between 46 cm and 59 cm by the end of the century. To counter the impacts of SLR, regional adaptation strategies will be needed because the extent of damage caused would vary from region to region depending on the slope of land, extent and nature of coastal development, population density, and local rate of SLR, existing coastal management policies, and local practices, among others (Dogra and Srivastava, 2012)

**Health Specific adaptations:** Adaptation includes strategies, policies, and actions undertaken to lessen the impact of climate sensitive health determinants and outcomes. In terms of the public health concepts of primary, secondary, and tertiary prevention, illustrative measures are as follows:• Primary prevention includes adaptation responses (like bed nets for preventing malaria) in anticipation of disease or injury induced by climate-sensitive factors. •

Secondary prevention involves interventions (like strengthening rapid response to a disease outbreak) put in place after the effect of climate related hazards has been felt or observed. • Tertiary prevention measures (like better treatment of heat strokes) seek to ameliorate the adverse effects of a disease or injury caused by climate-related extreme or adverse events.

Many adaptive measures have benefits beyond those associated with climate change. The rebuilding and maintaining of public health infrastructure is often viewed as the “most important, cost-effective and urgently needed” adaptation strategy. This includes public health training, more effective surveillance and emergency response systems, and sustainable prevention and control programs.

Adaptation measures recommended for India include, among other aspects, the following: awareness; capacity building of individuals, communities, and institutions; disease and vector surveillance; preparedness for disaster management, development of early warning systems as well as strengthening of primary and secondary health-care facilities.

**Suggested Projects**

**Project 1. Mapping of weather-related disease patterns in your locality**

**Background**

Weather and climate affect the social and environmental determinants of health particularly food sufficiency, safe drinking water, clean air and secure shelter. Weather variations heavily impact the health of people and climate change has an amplifying effect. Climate change affects disease dynamics directly (heat waves on stress induced strokes) and indirectly (increased activity of disease transmitting vectors). It is expected that, due to weather patterns, diseases alter their range, intensity, and timing.

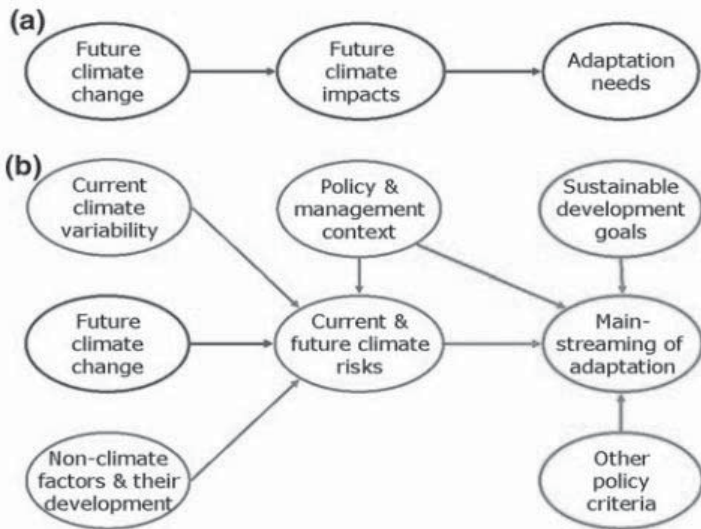

It is imperative to develop measurable indicators of health impacts. Such assessments would not only augment our understanding of the relationship between climate and health but also help in designing better adaptation strategies. Mapping is a important tool to gather information in its spatial dimensions and to help understanding spatial interrelationship among various map-able parameters leading to planning process. Detailed maps of such climate change-induced hot spots for all the sectors need to be developed, as health risks are linked with food, water, environment, and socio-economic

conditions (Dogra and Srivastava, 2012).

Many national level disease maps were prepared by different agencies in our country. Dengue and chikungunya epidemics in addition to malarial outbreaks with changing types and forms have been major problems for the public

healthcare system in India that killed thousands of people in the past few years. Environmental determinants and man-made factors have favourable to the breeding of *Aedesspp*, the mosquito responsible for the spread of these dreaded diseases. In 2012, chikungunya hit 18 Indian states with 14, 277 clinically conformed cases while dengue was reported from as many as 24 states with 37,070 confirmed cases (Palaniyandi, 2012). Based on the data, disease maps are prepared which provide clear idea of disease intensity.

### Objectives

- To identify diseases occurrence in your locality from secondary sources
- To collect the daily, weekly and monthly weather data (temperature, rainfall, humidity, etc.) of minimum five years period for your locality.
- To draw disease mapping based on the weather patterns in your locality

### Methodology:

1. The periodic collection of the secondary data on various diseases prevalent in the study area collected from different levels such as primary health centers or Government hospitals, Private medical centers and also from the local pharmacies for last five years.
2. Develop the questionnaire and collect data in relation to disease conditions in the last five years from minimum 200 households at random in your locality. From the individual data, a common data sheet to be prepared for analysis.
3. Collect the weather data of study area from local weather station or other authenticated data sources for last five years
4. Collect the base map of your locality from any authenticated sources. Prepare the disease maps based on the different seasons of your locality with gradations.

### Interpretation

1. Correlate the season-wise weather parameters with disease occurrence and find out significant association between weather changes and cluster of diseases.
2. Study the changes in the weather conditions of the study area and impact on diseases condition in your locality.
3. Based on the results, prevention, preparedness, medications and warming systems may be recommended.

## Project 2. *Incidences of sunstroke in your locality*

### Background

During summer, most areas of India also experience episodes of heat waves every year causing sunstroke, dehydration and death. In the national context, a number of studies in India show that the country has been experiencing extreme weather events for the past few decades, particularly after the 1990s. An analysis of daily climatological heat index (HI: combining temperature and humidity) over 41 districts well distributed over the country

indicated that maximum HI exceeding 45°C characterizes many districts during March to May and also during June to September. On the other hand, the wind chill index (combining temperature and wind speed) is less than 10°C for a very few districts of northern India mainly in winter (January - February) and the post-monsoon period (October–December). In 1998, major parts of north India and the northern parts of peninsular India experienced severe heat wave. During the second half of May, the heat wave was one of the severest ones seen in the last 50 years and led to the deaths of more than 2600 people. It is interesting to note that mortalities due to both heat waves and cold waves were highest in India in 2003 as compared to other years (Dogra and Srivastava, 2012).

Recently many cases of sunstroke were reported in the media. Such cases were never reported in the past as revealed from published literature, old hospitals records and senior citizen of the locality. So we consider it as problem to be investigated, in order to take precautions in the future to avoid such incidences.

### Objectives

- To understand sunstroke and its consequences
- To identify area from secondary sources and published data where incidences of sunstroke has been reported
- To collect the daily weather data of summer months for last five years for that area
- To draw relationships between weather and sunstroke and recommend precautions

### Methodology

1. Collect of the secondary data on incidence of sunstroke in the study area from different levels such as primary health centers or Government hospitals, private medical centers and also from the local doctors and pharmacies of last five years
2. Develop the questionnaire and collect data in relation to sunstroke in the last five years from household survey at random in the study area. From the individual data, a common data sheet to be prepared for analysis
3. Collect the weather data of study area from local weather station or other authentic data sources of last five years
4. Compare and analyze the weather and sunstroke data

### Interpretation

1. To understand the indicators of sunstroke
2. Interpret the weather parameters on annual basis in relation to the occurrence of sunstroke
3. Investigate whether there is any direct relationship between nature of work, life styles, habits or place and sunstroke

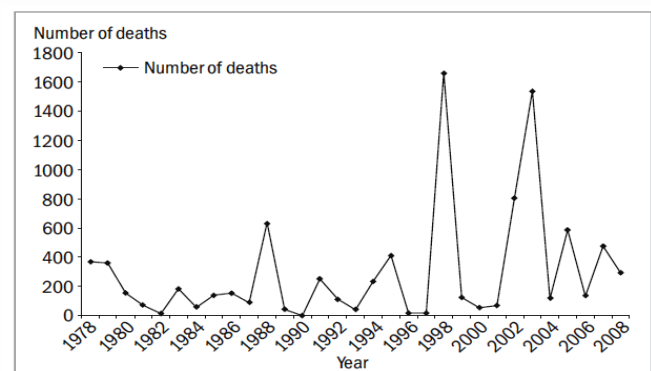

Heat wave deaths in India (1978–2008)

Source Based on IMD and NCC (Various years)

4. Identify the precautions that can be taken to avoid sunstroke
5. Based on the results, recommendations may be drawn which include prevention, preparedness, first-aid and warming system

### **Project 3. Prevalence of dengue fever in your locality. Is it weather related?**

#### **Background**

Dengue fever is a mosquito-borne viral disease estimated to infect about 50-100 million worldwide every year, of which 25,000 are fatal. Global incidence has risen rapidly in recent decades with some 2.5 billion people, over half of the world's population, now at risk, mainly in urban centers of the tropics and subtropics. Demographic, societal and weather changes, in particular urbanization, globalization, and increased international travel, are major contributors to the rise in incidence and geographic expansion of dengue infections. Major research gaps continue to hamper the control of dengue (Wilder-Smith *et al.*, 2012).

The spatial distribution of the main dengue vector, *Aedes aegypti*, has also increased over the last 25 years. Increase in both, dengue incidence and *A. aegypti* distribution have also been associated to variations in the climate system, including climate change. The evidence of the effects of climate drivers on dengue incidence is still under debate (Colo'n-González *et al.*, 2013). Therefore, the present work is undertaken at local level to find out the relation between weather conditions and dengue infection.

#### **Objectives**

- To collect information on the occurrence of dengue in a locality from various published or authentic secondary sources available from different levels of last five years.
- To collect the daily, weekly and monthly weather data (temperature, rainfall, humidity, etc.) of five years for the study area.
- To study weather indicators that may influence dengue transmission dynamics in a locality.
- To compare and analyze the weather data with infection pattern in the study area.
- To develop a comprehensive, early warning based on the results of data analysis.
- To determine the most useful and cost-effective predictive factors for dengue.

#### **Methodology**

1. The periodic collection of the secondary data on dengue prevalent in the study area collected from different levels such as primary health centers or Government hospitals, private medical centers and also from the local pharmacies of last five years.
2. Design and develop the questionnaire and collect data in relation to occurrence of dengue in the last five years from a minimum of 200 households at random from the study area. From the individual data sheet, a common data sheet to be prepared for analysis.
3. Collect the weather data of study area from local weather station or other authentic data sources of last five years.

4. Compare and analyze the survey data with weather conditions data. Conclude and infer on the basis of analysis.

### **Interpretation**

1. Compare weather parameters with dengue occurrence and find out significant association between weather changes and dengue.
2. Study the changes in the weather conditions of the study area and find out impact of dengue in the same.
3. Based on the results, recommendations may be drawn which include prevention, preparedness, medications and warming systems.

### **List of Projects**

1. Mapping of weather related diseases in your locality
2. Studies on prevalence of vector-borne diseases (malaria / dengue)
3. Occurrence of communicable diseases due to extreme weather conditions
4. Effect of temperature and humidity changes on incidences of skin diseases
5. Impact of weather on production and/or health of animals
6. Effect of extreme weather on the health of women and children
7. Effect of summer, winter and monsoon on incidence of respiratory diseases
8. Effect of heat on the health of farmers / industrial workers in your area
9. Studies on weather patterns and income loss of workers with daily wages
10. Studies on air-borne infections during variable weather conditions

### **Glossary of technical words**

**Adaptation** is adjustment in natural or human systems to a new or changing environment. Adaptation to climate change refers to adjustment in response to actual or expected climatic stimuli or their effects, which moderates harm or exploits beneficial opportunities. Various types of adaptation can be distinguished, including anticipatory and reactive adaptation, public and private adaptation, and autonomous and planned adaptation.

**Adaptive capacity** describes the general ability of institutions, systems and individuals to adjust to potential damages, to take advantage of opportunities or to cope with the consequences of climate change in the future.

**Climate:** Climate in a narrow sense is usually defined as the 'average weather', or more rigorously, as the statistical description in terms of the mean and variability of relevant quantities over a period of time ranging from months to thousands or millions of years. These quantities are most often surface variables such as temperature, precipitation, and wind. Climate in a wider sense is the state, including a statistical description, of the climate system. The classical period of time is 30 years, as defined by the World Meteorological Organization (WMO). In short, climate is the average state of the atmosphere and the underlying land or water in a specific region over a specific time scale.

**Climate change** refers to any change in climate over time, whether due to natural variability or as a result of human activity. Climate change is also defined as a statistically significant variation in either the mean state of the climate or in its variability, persisting for an extended period (typically decades or longer).



**Climate model** is a numerical representation of the climate system based on the physical, chemical, and biological properties of its components, their interactions and feedback processes, and accounting for all or some of its known properties. Climate models are applied, as a research tool, to study and simulate the climate, and also for operational purposes, including monthly, seasonal, and inter-annual climate predictions.

**Climate prediction** or climate forecast is the result of an attempt to produce an estimate of the actual evolution of the climate in the future, e.g., at seasonal, inter-annual or long-term time scales.

**Climate projection** is the calculated response of the climate system to emissions or concentration scenarios of greenhouse gases and aerosols, or radiative forcing scenarios, often based on simulations by climate models. Climate projections are distinguished from climate predictions, in that the former critically depend on the emissions/concentration/radiative forcing scenario used, and therefore on highly uncertain assumptions of future socio-economic and technological development.

**Climate-sensitive disease** is a disease that is sensitive to weather or climate factors, with the current spatial distribution and seasonal transmission being affected.

**Communicable disease** is an infectious disease caused by transmission of an infective biological agent (virus, bacterium, protozoan, or multi-cellular macro-parasite).

**Comparative risk assessment**, as defined by WHO is the systematic evaluation of the changes in population health that result from modifying the population's exposure to a risk factor or a group of risk factors.

**Coping capacity** is the means by which people or organizations use available resources and abilities to face adverse consequences that could lead to a disaster. In general, this involves managing resources, both in normal times as well as during crises or adverse conditions. The strengthening of coping capacities usually builds resilience to withstand the effects of natural and human induced hazards.

**Drought** is the phenomenon that exists when precipitation is significantly below normal recorded levels, causing serious hydrological imbalances that often adversely affect land resources and production systems.

**Endemic** (of a disease or condition) is the one that is regularly found among particular people or in a certain area.

**Environmental burden of disease** is the burden of disease caused by environmental factors estimated using methods described by WHO.

**Epidemic** is widespread occurrence of an infectious disease in a community at a particular time.

**Extreme weather event** is an event that is rare within its statistical reference distribution at a particular place. By definition, the characteristics of what is called "extreme weather" may vary from place to place. An "extreme climate event" is an average of a number of weather events over a certain period of time, an average which is itself extreme (e.g., rainfall over a season).

**Health** is a state of complete physical, mental and social well being and not merely the absence of disease or infirmity (WHO, 1946).

**Health impact assessment** is a systematic process to assess the actual or potential, and direct or indirect, effects on the health of individuals, groups or communities arising from policies, objectives, programs, plans or activities.

**Health risk assessment** is the process of estimating the potential impact of a chemical, biological, physical or social agent on a specified human population system under a specific set of conditions and for a certain time-frame.

**HVI** heat vulnerability index

**IPCC** Intergovernmental Panel on Climate Change

**Malaria** is an endemic or epidemic parasitic disease caused by species of the genus Plasmodium (Protozoa) and transmitted by mosquitoes of the genus Anopheles; produces bouts of high fever and systemic disorders, affects about 300 million and kills approximately 2 million people worldwide every year.

**Morbidity** is the rate of occurrence of disease or other health disorders within a population, taking account of the age-specific morbidity rates. Morbidity indicators include chronic disease incidence/prevalence, rates of hospitalization, primary care consultations, disability-days (days of absence from work), and prevalence of symptoms.

**Mortality** is the rate of occurrence of death within a population. Calculation of mortality takes account of age-specific death rates, and can thus yield measures of life expectancy and the extent of premature death.

**Outbreak** is a sudden occurrence of something unwelcome, such as disease.

**Pandemic**(of a disease) is the one that is prevalent over a whole country or the world.

**Vector** is a blood-sucking organism, such as an insect, that transmits a pathogen from one host to another.

**Vector-borne diseases** are the diseases transmitted to the hosts by a vector organism (such as a mosquito or tick); e.g., malaria, dengue and leishmaniasis.

**Vulnerability** is the degree to which a system is susceptible to, and unable to cope with, adverse effects of climate change, including climate variability and extremes. Vulnerability is a function of the character, magnitude, and rate of climate change and variation to which a system is exposed, its sensitivity, and its adaptive capacity.

**Weather** describes the day-to-day changes in atmospheric conditions in a specific place at a specific time. More simply, climate is what you expect and weather is what you get.

**Zoonosis or Zoonotic diseases** refer to diseases that can be passed from animals, whether wild or domesticated, to human beings.

### Health Tips for summer season

#### Prickly heat

- Intake of fluid with salt and lesser sugar
- Bathing twice or thrice
- Loose fitting light coloured cotton clothes
- Avoid applying prickly heat powder
- Application of sandal paste
- Drink butter milk and coconut water
- Avoid soft drinks

Activity: Collect more information on existing traditional health tips and practices and validate

## References

- Bentham**, G., Langford, I.H. 2001. Environmental temperatures and the incidence of food poisoning in England and Wales. *International Journal of Biometeorology* 45: 22-26.
- Burke** J. 2010. Hundreds Die in Indian Heatwave. *The Guardian* - news paper 30 May. Available: <http://www.guardian.co.uk/world/2010/may/30/india-heatwave-deaths> [accessed on 07 May 2014].
- Bush**, K.F., Luber, G., Kotha, S.R., Dhaliwal, R.S., Kapil, V., Pascual, M., Brown, D. G., Frumkin, H., Dhiman, R.C., Hess, J., Wilson, M.L., Kalpana B., Eisenberg, J., Kaur, T., Rood, R., Batterman, S., Joseph, A., Gronlund, C. J., Agrawal, A and Hu, H., 2011. Impacts of Climate Change on Public Health in India: Future Research Directions. *Environmental Health Perspectives* 119 (6): 765-770.
- Colo'n-Gonza'lez**, F.J., Fezz,i C., Lake, I.R and Hunter, P.R. 2013. The Effects of Weather and Climate Change on Dengue. *PLoS Negl Trop Dis* 7(11): e2503. DOI:10.1371/journal.pntd.0002503
- Dhingra**N, Jha P, Sharma VP, Cohen AA, Jotkar RM, Rodriguez PS, et al. 2010. Adult and child malaria mortality in India: a nationally representative mortality survey. *Lancet* 376: 1768–1774.
- Dogra** N. and Srivastava, S., 2012. *Climate Change and Disease Dynamics in India* [executive summary]. New Delhi: The Energy and Resources Institute (TERI), 27p.
- Füssel**, H.M., 2007. Adaptation planning for climate change: concepts, assessment approaches and key lessons. In: *Sustainability Science*. vol. 2.pp. 265–275.
- Hashizume**, M., Armstrong, B., Hajat, S., Wagatsuma, Y., Faruque, A.S., Hayashi, T., Sack, D.A. 2007. Association between climate variability and hospital visits for non-cholera diarrhoea in Bangladesh: effects and vulnerable groups. *International Journal of Epidemiology* 36: 1030-1037.
- INCCA**, 2010. *Climate Change and India: A 4x4 Assessment- A Sectoral and Regional Analysis for 2030s*. INCCA: Indian Network for Climate Change Assessment, Report No.2, Ministry of Environment & Forests, Government of India, 160p.
- IPCC** Intergovernmental Panel on Climate Change. 2007. *Climate Change 2007: Synthesis Report*. Contribution of Working Groups I, II and III to the Fourth Assessment Report of the Intergovernmental Panel on Climate Change (Core Writing Team, Pachauri RK, Reisinger A, eds). Geneva: Intergovernmental Panel on Climate Change.
- Kovats**, R.S., Edwards, S.J., Charron, D., et al. 2005. Climate variability and campylobacter infection: an international study. *International Journal of Biometeorology* 49: 207-214.
- Kumar** A, Valecha N, Jain T, Dash AP. 2007. Burden of malaria in India: retrospective and prospective view. *Am J Trop Med Hyg* 77(6 suppl):69–78.
- Mandal** K. 2008. Drinking Water Supply vis-a-vis Technological Interventions for Social Empowerment of Rural India. Available: <http://www.nistads.res.in/indiasnt2008/> [accessed on 07 May 2014].
- Jerrett, **Michael**, Jason G. Su, Colleen E. Reid, Bill Jesdale, Alberto M. Ortega Hinojosa, Seth B. Shonkoff, Edmund Seto, Rachel Morello-Frosch (University of California, Berkeley). 2012. *Mapping Climate Change Exposures, Vulnerabilities, and Adaptation to Public Health Risks in the San Francisco Bay and Fresno Regions*. California Energy Commission. Publication number: CEC-500-2012-041.
- Naish**, S., Pat Dale, P., Mackenzie, J.S., McBride, J., Mengersen, K and Tong, S., 2014 Climate change and dengue: a critical and systematic review of quantitative modelling approaches. *BMC Infectious Diseases* 2014 14:167
- M. **Palaniyandi**, M., 2012. GIS for epidemic control in India. *Geospatial World Weekly* 22 July 2013 at <http://www.geospatialworld.net/Paper/Application/ArticleView.aspx?aid=30612> [Accessed on 08-05-2014]
- Tuan**, L., 2013. Adaptation to Climate Change for Improving Public Health in Vietnam – Commentary. *Vietnam Journal of public health* 1(1):9-11.
- Wilder-Smith**, A., Renhorn, KE., Hasitha Tissera, H., Bakar, S.A., Luke Alphey, L., Kittayapong, P., Lindsay, S., Logan, J., Hatz, C., Reiter, P., Rocklo, J., Byass, P., Louis, V.R., Yesim Tozan, Y., Massad, E., Tenorio, A., Lagneau, C., L'Ambert, G., Brooks, D., Wegerdt, J and Gubler, D., 2012. Dengue Tools: innovative tools and strategies for the surveillance and control of dengue. *Glob Health Action* 5: 17273 - DOI: 10.3402/gha.v5i0.17273.
- WHO**, (2003). *Social determinants of health: the solid facts*, Wilkinson R G, Marmot M G (eds), World Health Organization, Copenhagen.
- WHO**. (World Health Organization). 2008. *World Malaria Report 2008*. Geneva: WHO.
- WHO**, 2014. Media Centre - Climate change and health - Fact sheet N°266 – Key facts <http://www.who.int/mediacentre/factsheets/fs266/en/> [Accessed on 08-05-2014]

## Additional Project Ideas (From the National Orientation Workshop)

### Sub Theme 1: Understanding Weather around you.

1. To study and analyze urban heat islands in your locality
2. Studies on micro-climatic variations in different eco systems in your study area.
3. Analysis of monsoon rainfall of past and present period for your locality.
4. Studies in wave erosion consequences in beaches of your locality (for coastal regions)
5. Setting of low cost weather station and analysis of data generated and comparison with weather station data for your area.
6. Studies on wind speed and direction in various sites of your locality in relation to weather data.
7. Establishment of micro-meteorological stations with local, low cost, available assets to observe and study the weather of a particular catchment area/locality and compare the data with secondary data from weather stations.
8. Study of landslides – mapping vulnerable points, reasons thereof for, study of exotic and indigenous plant species on landslides and correlating the various factors leading to landslides
9. Study of cloud bursts in terms of intensity, impact and coping mechanisms in a select area.
10. Study of cyclones and its impact – prevalence, frequency, and weather preceding and after the incidents.
11. When do you find whirl wind? Study its frequency, intensity and impacts.
12. Study of the impact of hail storms (as happened in 2014 in Maharashtra).
13. Study of weather pattern and shifting monsoons and other phenomenon with consultations with elderly people and correlation with historical data as well as measurement current weather parameters.
14. To study the variations of local weather conditions influenced by topographical features.
15. Study of the relationship between different types of weather and precipitation.
16. Analysis of rainfall trends (if possible probability of occurrence)
17. Moisture availability in a locality in different seasons
18. Study on diurnal of temperature variation under different land-uses
19. Study of temperature variations in an aquatic system
20. Study on characteristics of land and sea breeze and its impact on erosion of sand in Coastal area.
21. Comparative study on atmospheric, soil and water temperature in a locality.

### Sub Theme 2: Impact of Human activities.

1. Studies on heat production by air condition systems in any study area and analyzing alternatives.
2. Estimation of temperature in industrial / mining areas and its impact.
3. Monitoring air and water pollution in your locality.
4. Comparison of nature of houses (in terms of materials used, ventilation etc.) their design in terms of heat absorption and other weather parameters.
5. Study the impact of developmental activities on the micro climate/weather of your locality and compare the data with nearby areas not affected by the developmental activity.
6. Study the impact of vehicular pollution on micro climate at tourist destinations with reference to pre-tourist seasons, tourist season and post tourist season.
7. To study the carrying capacity of micro water sheds / local entrepreneurs in assisting pilgrims/tourists on religious routes and study seasonal variations, damages to eco systems, pollution etc.
8. Study the solid waste random disposal /landfill and its effect on nearby water resources and remedial measures.

9. Study the change in land use and land cover in your areas and its impact on climatic conditions.
10. Effect of coral and sand mining from sea shores and its changing impact with changing weather.
11. Study the impact of over exploitation of sand mining on various environmental parameters like water table, temperature of water in water bodies, change in quality of water, (physical, chemical, biological parameters) and larger impact on cropping/agriculture, livelihoods.
12. Impact of changing weather, climate on the mangrove forests, density, eco system as a whole.
13. Impact of glass claddings in modern buildings – study of micro climate inside versus ordinary buildings.
14. Impact of charcoal making (*Prosopis juliflora*) on wild life.
15. Study the impact of multi-storied buildings on the local wind velocity and sunlight intensity, temperature, humidity etc.
16. Study on desertification and salinization of land/soil
17. Comparative study on soil health in jhum cultivated and normal land

### **Sub Theme 3: Weather, Climate and Ecosystems**

1. Studies on micro arthropods /flora and fauna profiles and its seasonal variations in your study area.
2. Animal behavior as weather indicators – Collection of traditional experience and scientific validation.
3. Study of the growth rate of invasive (example *Parthenium*) species and its seasonal variations in your area and studying their adaptation capacities for adverse weather conditions in comparison to major crops.
4. Study of group migration of animals/birds/fish/plants and correlating the same with observed weather change / extreme weather events.
5. Study of Pond/Lake eco systems – temperature, water levels with reference to rain fall, study of life forms during various seasons (fish, frog, fresh water snakes, birds, aquatic plants, quality of water across seasons / varying temperatures / varying turbidity, etc.
6. Study of sacred groves – seasonal variations of life forms biomass, micro climate studies, interrelationships within the eco system, etc.
7. Study of coastal eco systems – Change of tides, High Tide Line, Low tide line over the years and its impact on coastal eco system, life forms, habitats etc.(Can be carried out as a combination of measuring tides – measured over two to three months - and also oral interviews with elderly fishermen in the area)
8. Study the impact of temperature variation on floral diversity and behavior of plants in an area.
9. Study of phonological changes in a rich biodiversity area with respect to changing weather/season.
10. To study the role of lichens with respect to climate change/weather and biodiversity in a select area.
11. Study of flora and fauna of a wetland in your locality and study seasonal changes if possible.
12. Study of aquatic and terrestrial ecosystems in terms of physical, chemical and biological parameters with respect to seasonal changes.
13. Study of shells and shell fragments from sea beaches and study seasonal variations in their diversity.
14. Study of fish catch in a coastal area and study the seasonal variations, quantum of catch and economic implications with respect to changing weather, seasons. (also oral interviews with elderly fishermen in the area)
15. Study of corals in terms of bleaching etc. with respect to changing weather, seasons.
16. Study of primary productivity in a pond ecosystem.
17. Study of carbon sequestration in pond/lake eco systems by studying bottom sediments.
18. Study of carbon sequestration in forest/grasslandsoil.
19. Study/measurement of canopy cover in different seasons of a forest (alternatively dense vegetation, sacred groves, large trees, school campus, parks etc.)

20. Study of a tree as an eco system more specifically a habitat – seasonal changes and changing diversity in niche specialization .
21. Study of sediment transport in a drainage channel/catchment by stakes-high measurement over seasons. (Eutrophication)
22. Impact of climatic variations of agro-forestry in an area.
23. Impact of rainfall variability on production of crops of an area.
24. Study of insect diversity of a grassland eco system (alternatively in wet land / dry land etc.)
25. Estimation of biomass in a grass species over the seasons.
26. Study of cow dung droppings and its disintegration as an indicator of soil microbial health.
27. Estimation of micro fauna of a desert eco system.
28. Study of bird migration due to weather / climate shift.
29. Study of changing housing patterns on sparrow population in a city.
30. Study of wetlands reclamation and its impact on micro climates, birds and other life forms – seasonal studies.
31. Study the impact of salty rains on the loss of grasslands in Banni region in Gujarat,-impact of weather and climate.
32. Study the impact of changing weather and climate on the eastern Himalayan glaciers
33. Study of local streams and seasonal variations and its impact on local agricultural practices. (Flow rates can be studied as small experiments )
34. Study on impact analysis of deforestation on soil and nutrient loss due to heavy rainfall and runoff in a simulated situation.
35. Study on earthworm, wasp, ant and other insects under changing environment due to change in climate and weather.
36. Litter disintegration studies in monocrop and multicrop soils
37. Impact of agricultural practices on soil faunal density and diversity
38. Soil faunal migrations in water logged paddy fields.... (premonsson - monsoon - post monsoon)
39. Crustacean larvae in estuaries.... (premonsson - monsoon - post monsoon)
40. Human adaptation in various ecosystems to food and livelihood....

#### **Sub Theme 4: Society and Culture.**

1. Studies on traditional knowledge and weather forecasting in your study area.
2. Scientific analysis of festivals in terms of weather in your locality and neighbourhood and comparison.
3. Study of seasonal food practices and its availability in terms of weather in your locality
4. Study of weather related folklore and proverbs of your state/area.
5. Analysis of school attendance in relation to weather / weather extremes and correlating to soci-economic background of absentees in the last 5 years.
6. Study of various types of firewood used and amount of soot production (studies related to quantification of the same) in your area.
7. Study of folk taxonomy and traditional knowledge of a particular area and linking them to traditional medicine / cultural values, practices etc.
8. Study of climate change/weather extremes and adaptation practices of the people and their culture in high altitude areas.
9. Study the merit of traditional houses in terms of weather parameters.
10. Effect of cultural / religious activities/functions on eco system in your locality.
11. Comparison of fishing activities, food, transportation during monsoon and other seasons in Lakshadweep region.

12. Traditional methods of predicting rains like movement of ants, height of crow's nest from ground.
13. Comparison of crop calendars of present and past and study the impacts on food habits and culture.
14. Identification, documentation, and validation of indicator plants related to soil moisture status, ground water availability, etc.
15. Study on indigenous methods of rainwater harvesting.

#### **Sub Theme 5: Agriculture.**

1. Using sun's heat to dehydrate vegetables to prolong their shelf life and get a better price.
2. Study on the effect of different sowing dates on the growth, flowering and yield of paddy (or of any other crop)
3. Impact of pollution on plant and soil health
4. Study of climate, weather versus vegetation changes in an area.
5. Organic versus in-organic agriculture – Comparative Studies related to performance in adverse weather and climatic conditions.
6. Study of traditional water harvesting and irrigation techniques and their relevance in changing weather and climatic conditions.
7. Impact of micro climate on various parameters of a crop including yield, total biomass production etc.
8. Effect of late monsoon on cropping pattern in your locality.
9. Change in irrigation pattern due to change in climatic conditions.
10. Impact of rainfall and temperature on horticulture and agricultural crops with special reference to Apple scab disease.
11. Analysis of parameters of weather conditions on controlled and open agriculture.
12. Measuring the water holding capacities of terraces in hills/micro water sheds and relating this to growth of vegetation/crops on different terraces.
13. Study the effect of strong winds on banana plantations, and the reducing the impact (quantification of reduction) by tying leaves of banana plants in the Narmada belt in Central Gujarat.
14. Study the effect of "rab" method – burning dried leaves, twigs, bark, cowdung cakes soil layer etc which is a practice of soil preparation during March throughout Konkan area of Maharashtra before sowing rice.
15. Study effect of changing weather on flowering pattern and fruit production in Alphonso mango which is a cash crop in Konkan region of Maharashtra.
16. Study the performance of different varieties of different crops which are adapted to extreme weather conditions like drought or water logging, increased temperature etc.
17. Comparative study of mixed cropping systems with that of mono culture in terms of total yield, total biomass yield, soil fertility etc. before and after cropping.
18. Study of mixed grains agriculture in Kutch region of Gujarat (Mixed grains are Isabgol, Jeera, Til, Jowar, Moong and Bajra which are sowed together. As the weather changes, different crops grow at different times depending on the gestation period of them. Effect of weather and climate on yield can be studied. This kind of method is called "sukhikheti" which does not need irrigation and tilling carried out by camels).
19. To measure impact of sunlight on the growth of crops in different types of soil.
20. Study the impact of changing weather and climatic conditions on Makhana/Sugarcane cultivation in North Bihar and UP.
21. Study of traditional agricultural practices of past and present practices in terms of changing weather.
22. Analysis of seasonal /perennial crops production in various weather conditions.
23. Analysis of milk density in different weather conditions in your locality.
24. Assessment of food habits of traditional people in view of possible supplement to food security
25. Study of the impacts of weather and climate change on traditional agricultural practices.

26. Study of salt farms in coastal areas of Kutch in different seasons.
27. Study of soil moisture retention and comparing them under mulching, drip irrigation etc.
28. Study of cropping pattern of a particular region as influenced by different seasons in the year (why a particular crop is grown in a particular season only?), effect of weather parameters on various crop stages.
29. Study of performance of hybrid livestock versus traditional livestock in terms of input costs versus output.
30. Study of effect of heavy rainfall on different crop stages and its effect on production.
31. Study of the effect of dry spells on different crop stages and ultimate effect on production.
32. Study of soil parameters (physical, chemical and biological) in changing weather extremes and its correlation with plant production, crop yields etc.
33. Study of seasonal milk production of various breeds of livestock in the same region – inputs costs versus milk output.
34. Study of different agricultural practices in relation to weather and climate (tillage, land preparation, sowing, transplanting, weeding, harvesting and post harvest in relation to local calendar systems.
35. Study of recommended practices (Agricultural University, KVK etc.) like ideal dates of sowing, distance of planting, pest/disease calendar etc. and documenting actual practices in field and their rationale with reference to changing weather/climate.
36. Effect of changing weather and climate on crop diseases, pest occurrence, emergence of old diseases/pests, whether minor pests emerging as major pests etc.
37. Study of different weeds with reference to changing weather on occurrence, growth, flowering and reproduction (overall life cycle)
38. Studies on effect of weather and climate on different crops/grain storage techniques/practices.
39. Study of modern agricultural practices which contribute for increasing levels of GHGs – eg. Deep ploughing, using high inputs like chemical fertilizers, pesticides, weedicides, farm machinery etc.
40. Study of innovative crop practices adapting to changing weather, climate and identifying components which are critical for improved performance in adverse weather and climatic conditions.
41. Study of sericulture in changing weather/climatic conditions.
42. Study of changing weather and climatic conditions on floriculture.
43. Comparative study of System of rice intensification (SRI) of paddy cultivation with conventional paddy cultivation with respect to less water intensive method.
44. Study of impact of weather and climate change in the traditional paddy cum fish culture in the Zino valley of Arunachal Pradesh.
45. Study of Jhum cultivation and its impacts on change of weather and climate of your locality.
46. Study of the practice of burning the stock of sugar cane on the next crop in Tamilnadu.
47. Study the impact of biochar on crop growth and soil parameters.
48. Study of short term vegetable cultivation versus long term crops as a strategy to cope with changing weather/ climate. (green vegetable cultivation).
49. Residual moisture based farming – Suitability for post monsoon crop.
50. Analysis of yield and quality of spices due to weather/climate change in hilly regions with special relevance to onset of South west monsoon.
51. Comparison of seasonal crop calendars and their variation within an agro-climatic zone – regional variations and differences and their rationale.
52. Comparative study on crop performance through hydroponics and normal crop production system.
53. Study on yield advantage of mono cropping and mixed cropping
54. Harvesting of rain water and its re-use



**Sub Theme: 6: Health:**

1. Study of weather related diseases in your locality – incidence, spread, treatment, expenditure, loss of livelihoods and correlation to socio-economic conditions of those affected.
2. Mapping of tropical diseases in terms of weather and finding out the vulnerability in terms of geography (landscape), social, economic and cultural factors of those who are more prone to the diseases.
3. Hospital based studies related to weather and climate and correlating with field level studies.
4. Analysis of agricultural / horticultural/ ornamental/cash crops in terms of weather extremes/climate change.
5. Mapping of vector borne diseases in your locality with special reference to re-emergence of certain diseases, mapping more vulnerable areas and linking them to health, sanitation etc.
6. Study the emerging diseases in higher Himalayan regions and correlate the same to temperature, rainfall and other weather parameters, climate change.
7. Participatory Village level mapping of your locality with reference to landscape, natural resources, health and sanitation facilities, vulnerable localities for epidemics and making a people plan for interventional strategies with pre and post intervention impact studies.
8. Study / documentation of working policy planning of various line departments with respect to onset of monsoon, weather extremes, disease incidence and strategies for coping with epidemics and finding out the efficacy of such plans and suggesting changes/modifications in a scientific manner.
9. Study of pattern of common diseases in the general population in relation to changing local weather conditions including seasonality, frequency etc.
10. Study of various skin diseases in the last three years in your locality related to changing weather, climate etc.
11. Study the quality of air in various environs – crowded, slums, textile industries, fly ash handling areas, bricks and cement industry etc. and study the seasonal variations.
12. Study the impact of weather and climate on food, fruits, vegetables, fish etc. and their durability during various seasons/weather.
13. To study the impact of changing weather / climate on industrial areas (thermal plants, stone crushing industry, textile, steel, glass industries etc.) on health and livelihood losses.
14. To study the impact of humid weather on skin related diseases/infections.
15. Prevalence of nature of disease in domestic animals as an effect of weather and climate.

**APPENDIX - I**

**Pond Measurements:**

Implementing pond management practices necessitates knowing the surface area and volume of the water impoundment. Aquatic herbicide applications, fish stocking rates and fertilization treatments are prescribed on the basis of area and/or volume of the pond.

you can measure your own pond by following the steps listed below. To assure accuracy, take all measurements carefully and carry all calculations to at least four or five decimal places (i.e., 0.11478 acres). After the final calculation has been performed, round the number to one decimal place.

**Surface Area**

Shoreline measurements are made with a tape measure or by pacing, and are then used in the appropriate formula below.

If the pond is **rectangular or square**, use the following formula:

$$\text{Surface area, in acres} = \frac{\text{Length, in feet} \times \text{Width, in feet}}{43,560 \text{ sqft / acre}}$$

**Example:** (Figure A)

$$\frac{80 \text{ feet} \times 140 \text{ feet}}{43,560 \text{ sqft / acre}} = 0.2571 \text{ acre, or approximately } 1/4 \text{ acre}$$

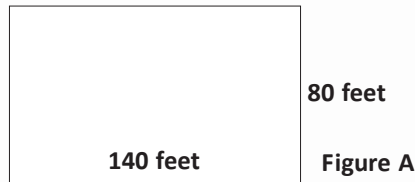

If the pond is circular or nearly so, use this formula to determine surface area:

$$\text{Surface area, in acres} = \frac{(\text{total feet of shoreline})^2}{547,390}$$

**Example:** (Figure B)

$$\frac{(520 \text{ feet}) \times (520 \text{ feet})}{547,390} = 0.4939 \text{ acre, or approximately } 1/2 \text{ acre}$$

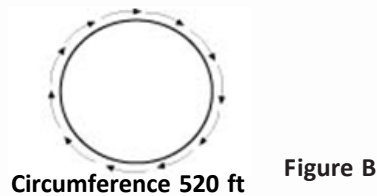

Many ponds are **irregularly-shaped**, which makes the area measurements more difficult. In this case, approximate the pond shape as a square, rectangle or circle by measuring boundary lines that most nearly represent the actual shoreline.

**Example:** This pond shape can be approximated as a rectangle (Figure C).

$$\text{Surface area, in acres} = \frac{\text{Length, in feet} \times \text{Width, in feet}}{43,560 \text{ sqft / acre}} = \frac{250 \times 120}{43,560} = 0.6887 \text{ acre}$$

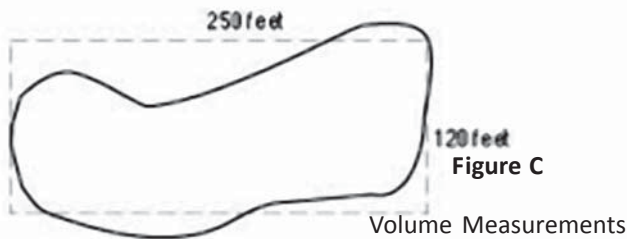

Calculating the total volume of water in the pond is a two-step process:

**Step 1:** Determine average depth of the pond by taking uniformly-spaced soundings over the entire pond surface. This can be done from a boat, or during the winter when ice covers the entire surface. The measurements can be taken with a long pole, chain or weighted rope marked off in feet. At least 15 measurements should be taken. Add the measurements and divide by the number of measurements taken.

**Example:**

$$\begin{aligned} \text{Average depth} &= (2+3+5+8+9+1+4+6+9+0+1+2+3+3+8) / 15 \\ &= \frac{64}{15} = 4.27 \text{ feet} \end{aligned}$$

**Step 2:** Once you have determined average depth and surface area, acre-feet are determined by multiplying the two measurements:

Volume, in acre-feet = Surface area, in acres X Average depth, in feet

Example: A 1.5-acre pond has an average depth of 4.27 feet.

Acre-feet = 1.5 acres X 4.27 feet = 6.405 acre-feet

**Measuring Small Areas Within a Pond**

Some pond management activities involve the treatment of only a portion of the water impoundment. In these situations, the same formulas are used but the treatment area dimensions are much smaller.

**Example:** A pond owner desires to treat a 50' x 100' swimming area for algae, using a rate of 2.7 pounds (equivalent to 1 part per million) of copper sulfate per acre-foot (Figure D).

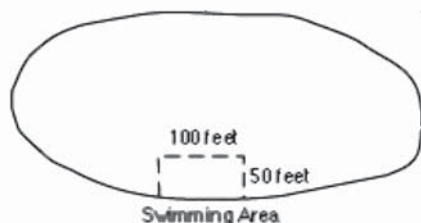

**Figure D**

$$\text{Surface area to be treated} = \frac{50 \times 100}{43,560} = 0.11478 \text{ acres}$$

$$\text{Average depth of swimming area} = \frac{1 + 2 + 3 + 5 + 2 + 3 + 4}{7} = 2.8571 \text{ feet}$$

Acre-feet in the swimming area = 0.11478 X 2.8571 = 0.32794 acre-feet

Amount of copper sulfate to use = 0.32794 acre-feet X 2.7 lbs per acre-foot  
 = 0.88542 lbs of copper sulfate in swimming area  
 = 0.9 lbs

**APPENDIX – II**  
**CONVERSION TABLE**  
**Units of Length**

**To calculate:**

Multiply measurement in: →	inches	feet	yards	miles	centimeters	meters	kilometers
inches by →	1	0.08333	0.02777	0.000158	2.54	0.0254	0.0000254
feet by →	12	1	0.33333	0.000189	30.5	0.305	0.000305
yards by →	36	3	1	0.000567	91.5	0.915	0.000915
miles by →	63,400	5,280	1,760	1	161,000	1,610	1.61
centimeters by →	0.394	0.0328	0.01093	0.00000621	1	.01	0.00001
meters by →	39.4	3.28	1.093	0.000621	100	1	0.001
kilometers by →	39,400	3,280	1,093	0.621	100,000	1,000	1

**Units of Area**

**To calculate:**

Multiply measurement in: →	sq. feet	sq. yards	sq. miles	acres	sq. meters	sq. kilometers
sq. feet by →	1	0.1111	3.587E-08	0.0000229	0.0929	9.29E-08
sq. yards by →	9	1	0.000003228	0.0002066	0.8361	8.361E-07
sq. miles by →	27,878,400	3,097,600	1	640	2,589,988	2.59
acres by →	43,560	4840	0.0015625	1	4,046.856	0.0040469
sq. meters by →	10.76391	1.19599	0.0000003861	0.000247	1	0.000001
sq. kilometers by →	10,763,910.40	1,195,990	0.3861	247.1	1,000,000	1

**Units of Volume (cubes)**

**To calculate:**

Multiply measurement in: →	cubic inches	cu. feet	cu. yards	cu. centimeters	
cu. meters					
cubic inches by →	1	0.0005787	0.000021433	16.387	1.639E-05
cu. feet by →	1728	1	0.037037	28,316.85	0.028317
cu. yards by →	46,656	27	1	764,554.86	0.764555
cu. centimeters by →	0.0610237	3.53147E-05	1.30795E-06	1	0.000001
cu. meters by →	61,023.70	35.3147	1.30795	1,000,000	1
ounces by →	1.8047	0.0010444	0.00003868	29.5735	2.957E-05
quarts by →	57.75	0.03342	0.00123778	946.353	0.0009464

pints by →	28.875	0.01671	0.00061889	473.176	0.0004732
gallons by →	231	0.13368	0.00495113	3,785.41	0.0037854
liters by →	61.0237	0.0353147	0.00130795	1,000	0.001

### Units of Volume (containers)

To calculate:

Multiply measurement in: →	Ounces	quarts	pints	gallons	liters
cubic inches by →	0.554113	0.017316	0.034632	0.004329	0.016387
cu. feet by →	957.5	29.922	59.844	7.48052	28.3168
cu. yards by →	25,852.70	807.896	1,615.79	201.974	764.555
cu. centimeters by →	0.033814	0.0010567	0.00211338	0.000264172	0.001
cu. meters by →	33,814	1,056.69	2,113.38	264.172	1,000
ounces by →	1	0.03125	0.0625	0.0078125	0.0295735
quarts by →	32	1	2	0.25	0.946353
pints by →	16	0.5	1	0.125	0.473176
gallons by →	128	4	8	1	3.78541
liters by →	33.814	1.05669	2.11338	0.264172	1

### Units of Weight/Mass

To calculate:

Multiply measurement in: →	Ounces	pounds	Tons	grams	kilograms
ounces by →	1	0.0625	0.00003125	28.3495	0.0283495
pounds by →	16	1	0.0005	453.592	0.453592
tons by →	32,000	2,000	1	907,185	907.185
grams by →	0.035274	0.00220462	1.1023E-06	1	0.001
kilograms by →	35.274	2.20462	0.0011023	1,000	1

### Units of Temperature

Conversion between degrees Fahrenheit (°F) and degrees Celcius (°C):

$$^{\circ}\text{C} = (^{\circ}\text{F} - 32) * (5/9)$$

$$^{\circ}\text{F} = (^{\circ}\text{C} * 9/5) + 32$$

## ANNEXURE I

## STATE WISE QUOTA FOR NATIONAL LEVEL AS WELL AS FOR ORAL PRESENTATION.

Sl.No.	State	Category	Projects at the National level	Ch. Scientist Teacher - Escort	Coordinator (SC/SAC)	Total	Projects for Oral Presentation
1	Andaman and Nicobar Island	T	4	1	1	6	1
2	Andhra Pradesh	M	17	4	1	22	3
3	Arunachal Pradesh	MS	10	4	1	15	2
4	Assam	B	26	7	2	35	5
5	Bihar	VB	30	8	2	40	6
6	Chandigarh	T	4	1	1	6	1
7	Chattisgarh	M	16	4	1	21	3
8	Delhi	S	8	2	1	11	2
9	Dadra & NH	VT	2	1	1	4	1
10	Daman & Diu	VT	2	1	1	4	1
11	Goa	S	8	2	1	11	2
12	Gujarat	B	26	7	2	35	5
13	Haryana	M	16	4	1	21	3
14	Himachal Pradesh	M	16	6	1	23	3
15	Jammu & Kashmir	M	16	6	1	23	3
16	Jharkhand	M	16	4	1	21	3
17	Karnataka	VB	30	8	2	40	6
18	Kerala	M	16	4	2	22	3
19	Lakswadwip	T	4	1	1	6	1
20	Madhya Pradesh	VB	30	8	2	40	6
21	Maharashtra	VB	30	8	2	40	6
22	Manipur	MS	10	4	1	15	2
23	Meghalaya	S	8	3	1	12	2
24	Mizoram	S	8	3	1	12	2
25	Nagaland	S	8	3	1	12	2
26	Orissa	B	26	7	2	35	5
27	Pondicherry	T	6	2	1	9	1
28	Punjab	M	16	4	1	21	3
29	Rajasthan	VB	30	8	2	40	6
30	Sikkim	T	4	2	1	7	1
31	Tamil Nadu	VB	30	8	2	40	6
32	Telangana	M	13	4	1	18	3
33	Tripura	MS	10	4	1	15	2
34	Uttar Pradesh	G	42	11	3	56	8
35	Uttaranchal	M	16	6	1	23	3
36	West Bengal	VB	30	8	2	40	6
	Sub total		584	168	49	801	118
37	Kendriya Vidyalaya Sangathan		42	-	-	-	8
38	Jawahar Navodaya Vidyalaya Samithi		32	-	-	-	6
	<b>Sub Total</b>		<b>658</b>				<b>132</b>

NB: 1: T-Tiny, VT-Very Tiny, S-Small, M-Medium, MS-Medium Small, B-Big, VB-Very Big, G-Giant: When Coordinators >1, the State Academic Coordinator also should attend. 2) For Remote State/UT: Escort Teacher 1 for 3 Children, for others 1 for 4 children. 3) Actual quota will get reduced to the percentage of districts covered in the state CSC programme.

**STATE COORDINATORS**

1. **Andaman & Nicobar Islands:** Shri S.K. Sinha, Andaman Nature Club, C/O DEO (Science), Shiksha Sadan, Link Road, Port Blair, A & N Islands 744101 Floor, E-mail: issinha@rediffmail.com Phone: 03192 (O) 250794; (M) 9332408522
2. **Andhra Pradesh:** Prof. Y. Nagesh Kumar, Member Secretary, A.P. Council of Science & Technology, 12th Floor, Eastern Wing, Gaganvihar, M.J. Road, Nampally, Hyderabad, Andhra Pradesh 500001, E-mail: secy\_apcost@ap.gov.in, Phone: 040 (O) 24619675, 24600590; (M) 9849908663
3. **Arunachal Pradesh:** Shri Debajit Mahanta, Arunachal Pradesh State Council for S&T, Ess- Sector, Itanagar, 791113 Arunachal Pradesh, Phone: 0360 (O) 2290833; (M) 9436059843, E-mail: debajit\_m@yahoo.com
4. **Assam:** Mr. Romen Gogoi, Irrigation Colony, KB Road, Near Circuit House, Jorhat, Assam-785001: Mobi: 0-9435052123, Email: romengogoi.jorhat@gmail.com
5. **Bihar:** Dr. Pawan Kishore Sharan, Science For Society, C/O Dept. of Chemistry, (New Building), Patna University, Patna 800005, Phone: 0612 (O) 2673343; (M) 09431095498, E-mail: sharanpawankishore90@gmail.com, sfsbihar@yahoo.com
6. **Chandigarh:** Mr. N.K. Jhingan, President, Environment Society of India, Karuna Sadan, Sector - 11, Chandigarh 160017, Phone: 0172 (O) 2746832; (M) 9417004937, E-mail: esichd@yahoo.co.uk
7. **Chattisgarh:** Dr. B.K. Rai, Project Director, Chattisgarh Council for S&T, No.25 Indravati colony Raipur, Chattisgarh 492007, Phone: 0771 (O) 2433964; (M) 09424242506, E-mail: dgcost@gmail.com; bkrai2009@gmail.com
8. **Daman & Diu Daman:** Shri B.S. Shrimali, Directorate of Education, U.T. Administration of Daman & Diu, Nani, Daman – 396210 Phone: 0260 (O) 2230550; (M) 9824767226 E-mail: damaneducation@gmail.com
9. **Dadra & Nager Haveli:** Sri. R.K. Gaur, Director of Education, Dadra & Nager Haveli, Near PWD Office, Silvassa-396230, Phone: 0260-2642006, Mob: 9558246625, Email: rakeshgaur4@rediffmail.com
10. **Delhi:** Shri. S.M. Faizani, State Coordinator, CSC (Delhi), Science Aur Kainat Society of India, E-71, 13 A Street, Kainat Lane, Ghaffar Manzil, Jamia Nagar, Okhla, New Delhi-110025, Email: smfaizani@gmail.com, Mob No: +91-7838999768
11. **Goa:** Dr. Joseph S. Rauto De' Souza Member Secretary, Goa State Council of S&T, C/o Dept. of Science, Tech. & Environ. Opp. Saligao Seminary, Saligao Bardez, Goa 403511 Phone: 0832 (O) 2407012 (M) 9623255354 E-mail: joephste@rediffmail.com, sanjiv3k@rediffmail.com
12. **Gujarat:** Dr. Narottam Sahoo, State Coordinator (NCSC), Satya Shodhak Sabha, 3, Abhinav Park, Ghoddad Road, Surat- 395001 Phone: 079 (O) 23259363 (M) 09879553960, E-mail: narottam.sahhhoo@gmail.com
13. **Haryana:** Shri Satbir Nagal, Secretary, Haryana Vigyan Manch, 77/29, Chankya Puri, Behind Sheila Bye Pass, Rohtak- 124001 Phone: 1262 (O) 213870; (M) 9215610535 E-mail: vigyanmanch@gmail.com
14. **Himachal Pradesh:** Dr. Hemant Gupta, Joint Member Secretary, H.P. State Council for Science, Tech. and Environment, Block 34, SDA Complex, Kasumpti, Shimla – 171009, Phone: 0177 (O) 2620998, (M) 931861625 E-mail: hemantgifs@gmail.com
- 15a. **Jammu & Kashmir:** Shri Shabir Ahmed Shabir, Regional Coordinator (Kashmir), J&K Students Welfare Society, Dukroo Building, K.P. Road, Anantnag, Kashmir -192101 Phone: 09858919626 E-mail: jksws@rediffmail.com
- 15b. **Jammu & Kashmir:** Shri Zaffar-Ullah-Khan, Regional Coordinator (Jammu), National Council For Urban & Rural Development Society, 775, Bahu Fort – 180006 Phone: 0191 (O) 2435598; (M) 9419281715, E-mail: jkncsc@rediffmail.com
16. **Jharkhand:** Shri D.N.S. Anand, Secretary, Science For Society, Jharkhand, 24, Shiv Nagar, Bagbera, Jamshedpur- 831002, Phone: 0657 (O) 2296047; (M) 9431953046, E-mail: sfs\_jsr@yahoo.com; manandsarita86@gmail.com
17. **Karnataka:** Sri. M.N. Musturappa, Karnataka Rajya Vijnana Parishat, Vignana Bhawan, 24/2 & 23, 21, Main Road, Near, BDA Shopping Complex, BSK II Stage, Bangalore, Karnataka 560070, Phone: 080 267189, 39 / E-mail: krvp.edu@datgaone.com, Mob: 9448857122
18. **Kerala:** Dr. Kamalakshan Kokkal, Scientist F, Kerala State Council for Science, Tech & Environment, Sasthra Bhavan Pattom P.O, Thiruvananthapuram, Kerala 695004, phone: 0471 (O) 22548213 (M) 9447489587, E-mail: envkscste@gmail.com, drkokkal@yahoo.com

19. **Lakshadweep:** Shri L.P. Pookoya, Asst: Director, Department of Science & Technology, U.T. of Lakshadweep, Kavaratti-682555, Ph: 04896-262005; (M) 9447611400, E-mail: pooks\_dweep@yahoo.com
20. **Madhya Pradesh:** Ms. Sandhya Verma, State Coordinator, NCSC, Science Centre (Gwalior), 1A DK2. Danish Kunj, Kolar Road, Bhopal, Madhya Pradesh, Phone: 0755 (O) 4203919; (M) 9425049756, E-mail: arunbhargava2science\_centre\_mp@yahoo.co.in
21. **Maharashtra:** Shri B.B. Jadhav, State Coordinator, NCSC, Jidnyasa Trust, Thane, 2, Jayanand Housing Society, Mahatma Gandhi Road, (Near TOI office) Thane(w), Maharashtra 400602, Phone: 022 (O) 25403857; (M) 9869043619, E-mail: jidnyastrust@gmail.com
22. **Manipur:** Dr.H.Manoranjan Sharma, Science Teachers' Forum, Manipur, B.T. Road, Post Box No.61, Manipur Public Library Complex, Imphal, Manipur 795001, Phone: 0385 (O) 2458317; (M) 9436035645, E-mail: lnabakumar816@gmail.com
23. **Meghalaya:** Shri C.P. Siyem, State Coordinator, NCSC, Meghalaya State Council Science, Tech. & Environment, Dhankheti, Shillong, 793001, Phone: 0364 (O) 2505511, 2223795; (M) 9436117517, 9436307170, E-mail: westrd@dte.vsnl.net.in, calmbertsyiem@gmail.com
24. **Mizoram:** Shri V. L. Malsawma, State Coordinator, NCSC, Science Teachers' Association, Building (Top Floor) Peter Street, Khatla, Aizawl- 796001, Phone: 0389 (O) 2334897, 2334902; (M) 9436366868, E-mail: vlmalsawma@gmail.com, stammizoram@gmail.com
25. **Nagaland:** Shri Santu Thapa, State Coordinator, NCSC, Nagaland Institute of Health Environment and Social Welfare, Opposite Commissioner's office, Old assembly Secretariate P.O, Kohima, 797001, Phone: 0370 (O) 22922086; (M) 03702292086, 974415175, E-mail: nihesw@yahoo.com
26. **Odisha:** Dr. R.N. Ray, Hony. Secretary, Bharat Jana Gyan Vigyan Samiti, N-3/309, IRC Village, Bhubaneswar, Orissa -751015, Phone: 0674 (O) 6532526; (M) 9437631557, ncscodisha@gmail.com
27. **Puducherry:** B.Ravichandrane, Pondicherry Science Forum, No. 10, II Street, Reddiarpalayam, Pondicherry 60501, Phone: 0413 (O) 2290733 (M) 9442786122, E-mail: cerdpsf@gmail.com
28. **Punjab:** Dr. Kulbir Singh Bath, State Coordinator, NCSC, Punjab State Council for Science & Tech., MGSPICA Complex (2nd Floor), Near Sacred Heart School, Sector 26, Chandigarh 160019, Phone: 0172 2792325, E-mail: ksbath@uahoo.com
29. **Rajasthan:** Shri Rajendra Jain, State Coordinator, NCSC, Department of Science & Technology, 312, Mini Sectt., Bani Park Jaipur, 302016, Phone: 0141 (O) 2202696; (M) 9414447101, E-mail: director@rajdst.gov.in
30. **Sikkim:** Mr.Suman Thapa, Asst. Scientific Officer, Sikkim Science Centre, Marchak, PO, Rani Pool, Gangtok, East Sikkim-737135, Phone: 03592-251026, Mob: 09434235351, Email: suman\_thapa@rediffmail.com
31. **Tamil Nadu:** Shri K.Kathavarayan, State Coordinator, NCSC, Tamil Nadu Science Forum, 245, Avvai Shanmugam Salai, Gopalapuram, Chennai, Tamil Nadu- 600086, Phone: 044 (O) 28113630; (M) 9751124532, E-mail: tnsfstatecenter@gmail.com, katha67@gmail.com
32. **Tripura:** Smt Panna Chakraborty, State coordinator NCSC, Tripura Science Forum, Thakur Ramkrishna Road, Kunjaban, Agartala, Tripura 799006, Phone: 0381 (O) 28113630; (M) 9436456709 E-mail: pannachak@gmail.com
33. **Telangana:** Sri.Y.Nageshkumar, Telagana State Council for Science & Tech., 12<sup>th</sup> floor, Easteran wing, Gagamvihar, Nampally, Hyderabad-500001, Phone:040 24619675, E-mail: Secy-apcost@ap.gov.in
34. **Uttar Pradesh:** Dr S.K. Singh, Director, Voluntary Inst. For Community Applied Science (VICAS), HD 86, Ada Colony, Naini Dist.Allahabad, Uttar Pradesh - 211008, Phone: 0532 (O) 2697088; (M) 09450961953, E-mail: vikasald@gmail.com
35. **Uttarakhand:** Dr.Ashok Kumar Pant, People's Association of Hill Area Launchers (PAHAL), Manas Mandir, Cantt. Road, Pithoragarh, Uttaranchal - 262501 Phone: 05964 (O) 225748; (M) 9412344870, E-mail: ashokntsc@gmail.com
36. **West Bengal:** Shri Arup Sengupta, Science Communicators Forum, No. 5 Dabur Park, Raja Subodh mallick road, Kolkata, West Bengal 700084, Phone: 033 (O) 24306446 (M) 9433924022, Email: kolkata.scf@gmail.com
37. **Kendriya Vidyalaya Sangathan:** Smt. Anjana Hazarika, Kendriya Vidyalaya Sangathan, No.18-Institutional Area, Shaheed Jeet Singh Marg, New Delhi - 110 016, E-mail: acacadkvs@gmail.com, Mob: 09968654354
38. **Jawahar Navodaya Vidyalaya Samiti:** Shri. G.Arumugam, Jawahar Navodaya Vidyalaya Samiti, B-15, Institutional Area, Sector-62, Noida, Uttarpradesh., Phone: 0120 (O) 2405948; (M) 9868184523, E-mail: garmu19@gmail.com



### **Members in the National Brainstorming Workshop.**

1. Prof. E KUNHIKRISHNAN, University college Trivandrum, TC 1/2021, JAYAMANJU, KUMARA PURAM, TRIVANDRAM , Tel.:09447653786 (M), Email: ekunhi@gmail.com
2. Dr.P. Pramod, Senior Scientist, Sálím Ali Centre for Ornithology and Natural History, Anaikatty. P.O. Coimbatore, Tamilnadu. Phone 91 422 2203115 Cell.09443167773, Email: neosacon@gmail.com
3. Dr.M.R. Ramesh kumar, Chief Scientist,National Institute of Oceanography, Goa-403004, Mob.9423056323., Email: rameshkumar.mr@gmail.com
4. Prof. A.S. Unnikrishnan, Chief Scientist, National Institute of Oceanography, Dona Paula - Goa, 403 004, Mob.No.9637097405, Email: unni@nio.org
5. Dr.S. Dinakaran, Associate Proff,The Madura College , No120\3, Siva Siva st, Alagappan Nagar, Madurai-625003, Mob.No. 9994900064., Email: dinkarji@gmail.com
6. Shri. Harish Bhat, Scientist Centre For Ecological Sciences, IISC, Bangalore 560012, Mob. 9845304383 Email: harishrbhat@gmail.com
7. Dr.K.Sambandhan, Associate Prof,P.G.Department of Plant Science , Avvaiyar College, Karaikkal, Puducherry UT, Mob. 9489260386., Email: sambandhan@gmail.com
8. Prof.(Mrs.)V. Geethalakshmi, Agro Climate Research Centre,Agricultural College and Research Institute, Tamil Nadu Agricultural University, Coimbatore-641003, Phone 422-2430657 Mob. No.9994433479.Email: geetha@tnau.ac.in
9. Dr. Pulin Bihari Chakraborty, Bidhan Chandra Krishi Viswavidyalaya A/81 Lake Gardens, Kolkata. 700045, Email- pbc0251@gmail.com
10. Shri. Jayanta Kr. Sarma, Freelance consultant (Environment and Development), Debasis Residency Near N.HNO.34 Manikachanpath Kailash Nagar, Beltola Guwahati -781028, Tel. :09613853818, Email- jayanta.sarma@gmail.com
11. Dr. Hemchandra.C. Pradhan , Former Director, Homi Bhabha Centre for Science Education, 702/B-1, Geetanjali Krishna Kamal CHS, Sector-21, Nerul East, Navi Mumbai – 400706, Mob. .09867050422, Email- hcpradhan46@gmail.com
12. Dr. Lalit Sharma, Science Communicator, Veterinary Consultant, Managing Trustee- Vigyan Setu Foundation, D-28/1:1, Sector-3, Sanpada, Navi Mumbai-400705.Tel.:09322264173, Email- drlalitsharma9@gmail.com
13. Dr. Sunil Nautiyal, Associate Professor of Ecology, Institute for Special and Economics Change Dr.VKRV Rao Road, Nagarabhavi P.O. Bangalore-560072, Tel.:080-23215468, 23215519, Extn: 246(O), 09731564784, Fax:080-23217008 09886092494(M), Email: Nautiyal\_sunil@rediffmail.com
14. Dr. Sudip Mitra, Asst. Prof,Department of Environmental Science, Tezpur University, Assam- 784028, Mobile:8486066392, Email- sudipmitra@yahoo.com
15. Er.C.E. Karunakaran, Senior Scientist , Centre for Ecology & Rural Development, Puducherry, No.26, Spurtank road,Chetpet, Chennai.Mob. No.9381041615., Email- cekarun@gmail.com
16. Prof. K.R. Janardhanan, Chithrawariamlane,Thrissur,Kerala.Mob- 94479-91392, Email: krj231@rediffmail.com
17. Prof. U.C. Mohanty , Indian Institute of Technology, Bhubaneswar, School of Earth, Ocean and Climate Sciences, Bhubaneswar-751 013, Phone No.(O) 0674 2576117, Email:ucmohanty@iitbbs.ac.in., ucmohanty@gmail.com
18. Dr. A.V.M.Subba Rao, Senior Scientist (Agromet), Central Research Institute for Dryland Agriculture, Santoshnagar, Hyderabad-500059 Mob..9640386358, Email: avmsrao@crida.ernet.in
19. Dr.V.R.S. Rawat ,Additional Director, Indial Council of forestry Research and Education, Dehradun-248006, Phone : 0135-2224805, Mob .9412058405, Email: rawatvrs@icfre.org/rawatvrs@gmail.com
20. Dr.Hemant Pande, Proffesor, Head, Dept. of Chemistry, Hislop College Nagpur, (M), Mob.9096050151, Email: pandehm@gmail.com
21. Dr.M.A. Haque, Director(Ret), Ministry of ENV.& Forest,C-1713, Palam Vihar, Gurgaon - 122017, M o b . 9313707275. Email: asrarulhaque@hotmail.com

22. Dr.V.Krishnan, No.7, Nethaji Street,Sorna Nagar, Ariyankuppam, Puducherry -7, Mob. 9486199177. Email:vazhmoorthy@gmail.com
23. Dr. Sultan Ahmed Ismail, Mananging Director, ERF, 98,Baaz Nagar,3/621, East Cost Road,Palavakkam, Chennai-600041, 044 24920786, Tel.: 09384898358, Email: sultanismail@gmail.com
24. Dr. K.V. Devi Prasad, Professor , Department of Ecology & Environment Science, Pondicherry University, Mob.No.8220933094, Email:kv.deviprasad@gmail.com
25. Er.P.K.Rajan, Writer, Science Publications, W481\C1, Praveen Virata flats, 2<sup>nd</sup> Avenue, Anna Nagar, West Ext. Chennai., Mob.9791099730.Email: Pkrajan\_61@yahoo.co.in
26. Khwaja Mohd Rafi, General Secretary,NCSTC Network, E56, Pandav Nagar,Samuspur Road, Delhi., Mob.No..9873717806., Email: kmrafi1@gmail.com
27. M.C.Arunan, Visiting Scientist,HBCSE, TIFR, Mumbai, D3, Gurukul Sophia College,Mumbai- 400026, Mob.No..9969262050., Email:mcarunan@gmail.com
28. Mr.Charles Emmanuel, RITIMO Network for information,21 ter Rue Voltaire, 75011 Paris, France, Mob.033646000755, Email:rtm@ritimo.org
29. Prof.S.Mohana, Tamil Nadu Science Forum. Palani, Tamilnadu, Mob.9443044642, Email:smohana@gmail.com
30. Prof.Rajamanickam, Tamil Nadu Science Forum, M.428 TNHB Colony, Ellis Nagar, Madurai-625010, Mob.No.9442915101, Email: vignanasirgu@gmail.com
31. Dr. D.C. Uprety, Emeritus Scientist, IARI New Delhi, H69,Vikaspuri, New Delhi-110018, Mob. 09871986313, Email: upretydc@gmail.com
32. Raghunath.T.P, Programme Coordinator, Pondicherry Science Forum, 10, IInd Street, P.R.Gardens, Reddiarpalayam Puducherry-605010, Mob.No.9443225288, Email:tprmenon@gmail.com
33. M.Sudurshan, State Academic Coordinator -NCSC, Pondicherry Science Forum, 10, IInd Street, P.R.Gardens, Reddiarpalayam, Puducherry-605010, Mob.No.9488074341, Email: sudurm@gmail.com
34. Dr.P.Iyamperumal, Excutive Director, Tamilnadu Science & Technology Centre, Gandhi Mandapam Road, Chennai-600025, Mob.No.9840014412, Email:driyamperumal@yahoo.com
35. Dr.S.Soundrarajaper, Joint Director, Tamilnadu Science & Technology Centre, Gandhi Mandapam Road, Chennai-600025, Mob.No.94444413200, Email:sounder.palani@gmail.com
36. Dr.R.Srinivasan, Scientific officer, Tamilnadu Science & Technology Centre, Gandhi Mandapam Road, Chennai-600025, Mob.No.9444455819, Email:srinivasan61@yahoo.com
37. S.Sekar ,General Secretary, Pondicherry science Forum, 10, IInd Street, P.R.Gardens, Reddiarpalayam, Puducherry-605010, Mob-.948977796, Email:sundarasegar@gmail.com
38. B.Ravichandrane, State Coordinator -NCSC, Pondicherry Science Forum, 10, IInd Street, P.R.Gardens, Reddiarpalayam, Puducherry-605010, Mob.9442786122, Email: ravibala63@gmail.com

**LIST OF PARTICIPANTS IN THE NATIONAL ORIENTATION WORKSHOP,  
CHENNAI, 3-5 JULY 2014**

**Andhrapradesh**

1. M.S.S. Lakshmi Watts, SCERT- AP, Opp. to Lal Bahadur Stadium, Egatebashirbag, Hyderabad - 500001, Phone: 9177543197, Wattslakshmi777@gmail.com
2. Sri M.Srinivasulu, GHS, Podili, Poldili VII., Prakasam Dt. Andhra Pradesh -,523230, Mob: 9490174988, Udayagiri.reddy@gmail.com
3. D.Venkata Subba Naidu, ZPHS, Lakkalavaripalli Vil., Ganjikunta Post, Mydukur Mandal, Kadapa Dt.,516173, Mob: 08790564408, Email: dvsubanaidu@gmail.com

**Assam**

4. Dr. Arup Kumar Misra, Dept. of Chemical Engg. Guwahati -781013 ASSAM, Phone: 0361-2674128 / 2734029 / 09435019520, arupkmisra@gmail.com
5. Dr. Manjit Kumar Bhattacharyya, Dept. of Chemistry, Cotton College, Panbazar, Guwahati Assam-781001, Phone: 09435013331, manjitbhattacharyya@yahoo.com
6. Dr. Utpal Rajguru, Dept., of Zoology, Jagi Road College P.O, Jagiroad, Morigaon, Assam-782410, Phone: 09435319272, Urajaguru08@gmail.com

**Bihar**

7. Dr. Pawan Kishore. Sharan, Cauty's Compound Church Road, Bhagalpur, Bihar- 812001, Phone: 0641-2420158 / 0641-2422759 / 9431095498, Email: Sharanpawankishore90@gmail.com
8. Dr. Sachidanand. Pandey, Dept of Geography, TMB University, Bhaglpur, Bihar – 812002, Phone: 0641 2620865, 09431865109, Email: Pandey52@gmail.com
9. Dr. Nagendra Prasad . Roy, Roy Niketan, Above Mian, Restaurant Kalambag Road, Muzaffarpur, Bihar, Phone: 0621-2240312 / 09006500938

**Chattisgarh**

10. Prof. M.M. Hambarde, Director General, CG Council of Science & Technology, MIG- 25, Indravati Colony, Raipur – 492007, Phone: 0771 2434569, 07389487146, dgccost@gmail.com
11. Dr. Piyush Kant Pandey, Principal, Bhilai Institute of Technology, Kendri, NH43, Near Abhampur, Raipur. Phone: 0771 2120232, 09669871234, principal@bitraipur.ac.in
12. Dr. Manisha Madhukar Ruikar, No.701, Type VA, AIIMs, Residential Colony, Kabirnagar, Raipur-492009 Phone: 8951881909, manisharruiikar@rediffmail.com

**Karnataka**

13. Shri Pandit K. Balure, Adjyanilay, Basayeshvara, Colony, Humnabad dist, Bidar, Karnataka-585330 Phone: 09731089623, Pandit.kbalure@gmail.com
14. Sri. Nayak Venkatray Narayan, Karnataka Rajya Vijnana Parishat, Vignana, Bhawan, Uttara Kannada Dist. Science centre Kodibag, Karwar- 581303, Ph: 0838-2221448, 09449032795, Email: Venkat\_nike@rediffmail.com
15. Dr. Jayakara Bhandary.M, Dept. of Botany, Govt First Grade College, Karwar, Karnataka -581301, Phone: 08382-226362 / 9481110190, mbjaikar@gmail.com

**Kendriya Vidyalaya Sanghatan**

16. D. Venkateswarlu, Principal, Kendriya Vidyalaya No- 1, Ramnagar Area, Tirupati -517507, Phone: 9550025755, 0877-2232755, 9550025755, Email: Kv1tpt@gmail.com
17. Sri.K. Arumugam, PGT (Physics), Zonal Institute of Education & Training, Siddarth Nagar P.O, Ragavendra Nagar, GITP Press Campus, Mysore -570011, Phone: 082 2470345, Mob: 8762543662, Email: ar\_umk@yahoo.co.in
18. Sri.S.Dhamodharan, PGT Physics, Kendriya Vidyalaya, Ashok Nagar, Chennai-600083, Ph: 044 24740011, Phone: 94434080636, sdhamodharan@rediffmail.com
21. Dr. Awati Anita Jaipal, Neelmohar, Swarupnager, AT Post, Khed Tehsil, Khed District. Ratnagiri - 415709, Phone: 02356264714/ 9960033567, anitaawati@yahoo.in,

**Manipur**

22. Dr. KK. Manibhushan Singh, Assist. Professor, Dept. of Environmental Science , DM College of science, Imphal-795001 . Manipur West. Ph : 0385-2413618/ 9612950567, koibhushan@yahoo.com
23. Rajkumar Imosana Singh, Science Teachers Forum-Manipur, Lecturer, Oriental college, Takyel-Imphal 795001, Manipur.9612626564, Imosana\_rk @yahoo.com

**Jawahar Navodaya Vidyalaya Sanghatan.**

24. Mr.A. Vinayathan, Principal, Jawahar Navodaya Vidyalaya, Periyakalampet, Puducherry- 605014, Phone: 0413 2655133, 09443829983, jnvpuuducherry@gmail.com, avinayathan@gmail.com
25. Smt. G. Anusuya, Principal, Jawahar Navodaya Vidyalaya, Rayanpalayam, Varichikudy , Karaikal, Puducherry -609609, Phone: 04368 2662313, 9443536435, anug\_2004@yahoo.co.in
26. Sri. Subramanya SR, PGT (Geography), Jawahar Navodaya Vidyalaya, Bashettihalli, Doddaballapur T.K, Bangalore -562163, Phone: 9742174375, sorasugeo@gmail.com

**Odisha**

27. Dr.Gokul Krishna Panda, District Education Office Ganjam, Giri road, Berhampur, Ganjam, Odisha -760005, Phone: 09437521249, gokulpanda2@gmail.com
28. Mr. Pratap Chandra Parida, Bharat Jana Gyan Vigyan Samiti , Plot No. 5D , 904 Sector R-9 CDA , Cuttack, Odisha, Phone : 08895285317, Pratap.parida.iems@gmail.com

**Puducherry**

29. Sri. M.Sudurshan, Pondicherry Science Forum, 10, IInd Street, P.R.Gardens, Reddiarpalayam, Puducherry-605010, Mob.No.9488074341, Email: sudurm@gmail.com
30. Dr.K.Sambandhan, Associate Prof., Department of Plant Science , Avvaiyar College, Karaikkal, Puducherry -609602, Mob. No.9489260386., 04368-226380, Email: sambandhan@gmail.com
31. Sri. B.Ravichandrane, Pondicherry Science Forum, No. 10, II Street, Reddiarpalayam, Pondicherry 605010, Phone: 0413 (O) 2290733, (M) 9442786122, ravibala63@gmail.com

**Punjab**

32. Dr. Balwinder Singh Sooch, Astt, Prof, Dept., of Biotechnology, Punjabi University, Patiala-Punjab-147002, Phone: 0175-304263, Mob: 9815491199, Email: Soochb@yahoo.com
33. Sri. Surinder Singh Bajwa, Lecturer in Physics , D.I.E.T. Ropar, Punjab - 140001, Phone: 01881-227661, 09417027661, Email: kingbajwa@yahoo.com
34. Sri. Anupam Madan, Science Master, CMS, Khillan, Tehsil, District, Mansa Panjab-151505, Ph : 982680756, Email: mansadac@gmail.com

**Tamilnadu**

35. Dr.S. Dinakaran, Associate Pro, The Madura College , No120\3, Siva Siva st, Alagappan Nagar, Madurai-625003, Mob.No. 9994900064., Email: dinkarji@gmail.com
36. Prof. .S.Mohana, Tamilnadu Science Forum, 61, A. Anna Nagar, Palani -624601, Tamilnadu, Mob.No.9443044642 Email: smohana@gmail.com
37. Shri K.Kathavarayan, Tamilnadu Science Forum, No.2 Kammalar Street, Pudupalayam P.O, Chengam T.K., Thiruvannamalai, Tamilnadu -606705, 04181 246275, 09751124532, Email: Katha67@gmail.com
38. Sri.C.Ramalingam, Tamilnadu Science Forum, 245, Avvai Shanmugam Salai, Gopalapuram, Chennai. Phone: 9444247658, Email: contactcra@yahoo.com

**Telengana**

39. Sri G.Ramesh Babu, ZPHS Tirumalagiri G, Chivvemla- Mandal, No. 1-2-270/87/27, Krishna Colony, Suryapet, Nalgonda, Telengana-508213, Ph: 9848431030, Email: rameshbabunlg@gmail.com

**Tripura**

40. Prof. Jyothi Prakash Roy Choudhury, Tripura Science Forum, Thakur Ramkrishna Road, Kunjavan, Agartala, Tripura 799006, Phone: 0381 (O) 2359794; (M) 094365-83382, Email: jprc2010@gmail.com

**Uttar Pradesh**

41. Dr. V.P Singh, Jaidev nagar, Rajgadh, Lakimpur Keri , UP- 262701, Phone: 0587 263651 , 09415148410, Email: terieco@yahoo.com

**West Bengal**

42. Prof. Subhasis Mukhopadhyay, Science Communicators Forum, No. 5 Dabur Park, Raja Subodh Mallick road, Gangulibagan, West Bengal 700084, Phone: 033 (O) 24306446 / 09475849931, Email: Sm.bmbg@gmail.com
43. Shri Dipen Roy, Science Communicators Forum, No. 5 Dabur Park, Raja Subodh Mallick road, Gangulibagan, West Bengal 700084, Phone: 033 (O) 24306446 / 09433354092, Email: Roydipen116@gmail.com
44. Sri Saikat Ganguly Science Communicators Forum, No. 5 Dabur Park, Raja Subodh Mallick road, Gangulibagan, West Bengal 700084, Phone: 09674623026, Email: saikatgnl@gmail.com

**Goa**

45. Dr. Joseph S Rauto Desouza, Chief Scientist, Goa State Council of S &T, Opposite Saligao Seminary, Saligao, Bardez, Goa - 403511, Phone: 0832 2407012, 096232-55354, Email: josephste@rediffmail.com

**Chandigarh**

47. Sri.. Rakesh Dahiya, Environment society of India, No.1003 A, Sector 20 B, Chandigarh- 160020, Phone: 0172- 2746832 / 09855751515, Email: Rakeshdahijya5678@yahoo.in
48. Sri. . Sanjay Kumar, Environment society of India, No.503-A, Sector 7B, Chandigarh- 160019, Phone: 0172- 2795503 / 09814455466, Email: sanjaypooja18@yahoo.in

**Uttarakhand**

49. Dr. Balwant Kumar, Asst Professor, Dept. of Botany, Kumaun university SSJ Campus, Almora, Uttarakhand - 263601, Phone: 09758023091, Email: drbalwantkumarya@gmail.com
50. Dr. Suneet Naithani, Assistant Professor, Doon University, Dehradun, Uttarakhand-248001, Phone: 0135- 2533103, Mob: 9456547707, Email: suneetnaithani@gmail.com

**Madhya Pradesh**

51. Dr. S.K. Kulshreshtha, Science Centre, 27/3 Geetanjali complex, Bhopal MP-462003, 0755-2772932 / Mob: 9425377847, drskkulshreshtha@yahoo.co.in
52. Dr. Vipin Vyas, Dept. of Limnology and Environmental Science, Barkatullah university, Bhopal MP-462028 Phone: 0755 2517126 / 0774604110, Email: vyasvipin992@gmail.com
53. Dr. Shriparna Saxena, Dept. of Limnology and Environmental Science, Barkatullah university, MIG- DX - 242A, Katara Hills, Bhopal- 462028., Phone: 0755 2481842 / 9229200243, Email: shriparanroysxena@gmail.com
54. Dr. Pankaja Singh, G-6 Fortune glory, E-8, Bhopal MP -462039, Mob: 9425007334, Email: pankajasingh@gmail.com

**Gujarat**

55. Dr. Jitendra Gavali, Community Science centre Vadodara, Aarti Society, Near Atmajyoti Ashram, Subhanpura, Vadodara, Gujarat—390023, Phone: 0265 2389749/2417794, Mob: 9725891033, Email: jggavali@gmail.com
56. Sri. Pandya Sanjay Ramnikbhai, Darbargadh, Dhrol, Jamnagar, Gujarat -361210, Ph: 902897223636 / 979241100, Email Sanjaypandya48@gmail.com
57. Mrs. Swati S Bedekar, AL- 30 Jay Ranchod Society, Gotri Vasana, Connecting Road, Vadodara, Gujarat - 390015, Phone: 0265 6543454, 09824058675, Email: swatibedekar@gmail.com

**Kerala**

58. Prof. K.P. Thrivikramji, KSCSTE Pattom, Sasthrabhavan, Trivandram -695004 Ph.0471-2350152, 09446425842, Email: thrivikramji@gmail.com
59. Dr. P. Harinarayanan, KSCSTE, Sasthra Bhavan, Pattom, Trivandram -695004, Ph: 0471 2548299, 9447450715, Email: pharinarayanan@gmail.com
60. Er. Binuja Thomas, KSCSTE, Sasthrabhavan, Pattom, Trivandram -695004, Phone: 0471 2548211, 9447207142, Email: binujathomas@gmail.com

**Lakshadweep**

61. Sri. MG Thulasidas CEO, Education Officer, Dept. of Education, Kavaratti, Lakshadweep -682555, Phone: 0489- 6263835 / Mob: 9447667559, mgthulasidas@gmail.com
62. Sri. Syed Mohammed Hassan, GSSS, Kavaratti, Lakshadweep -682555, Phone: 0489 6263835 / 9447982021, Email: athan000@gmail.com

**Arunachal Pradesh**

63. Dr. Swapna Acherjee, Arunachal Pradesh Science centre, JP,Park , Itanagar-791111, Phone: 0360 2290835, Mob: 9436046709, Email: apsc-curator@yahoo.com
64. Dr. Debajit Mahanta, Arunachal Pradesh Council for Science & Tech, ESS- Sector , Itanagar - 791113, Arunachal Pradesh, Mob: 09436059843, Email: Debajit\_m@yahoo.com
65. Sri. Vivek Kumar, Curator, Arunachal Pradesh Science Centre, IG Park, Itanagar, Arunachal Pradesh-791111 Phone: 0360-2290835, 9436046709, email: apsc-curator@yahoo.com

**Jammu & Kashmir**

66. Dr. Ashaq Hussain, Dept. of Chemistry, Govt. Degree College, Kishtwar, Jammu & Kashmir - 182204. Phone: 01995-259513 / 9419905599, drashiqhussain@rediffmail.com
67. Mr. Muhammad Yosuf Zagoo, Principal, High School, Watnard, Kokernag, Anantnag, Kashmir- 192202 Phone: 9797203600, Zag00786@gmail.com
68. Mr. Kuldeep Gupta, National Council for Urban & Rural development Society, H.No.621, Ashok Nagar, Jammu Cant, J&K-180003, Phone : 9906078038, gptkldp@rediffmail.com

**Mizoram**

69. Dr. HS Thapa, Dept., of Botany, Pachhunga University College, Aizawal, Mizoram, Phone: 0389 2322557/ 2327633, 09436153326, thapahs@rediff.com
70. Dr. KC Lalmalsawmzauva, Assistant professor, Dept., of Geography Mizoram University , Aizawal , Mizoram - 796004, Phone: 08974319488, Email: kcmalsawma@rediffmail.com

**Himachal Pradesh**

71. Dr. Pankaj Sharma, HP State Council for Science, Tech & Env , No.34 SDA Complex, Kasumpti, Shimla, Himachal Pradesh - 171009, Phone: 0177-2620998/ 09418776534, Email: Spankaj80@gmail.com
72. Shri Ravi Sharma, HP Council for Science & Tech & Env , 34, SDA Complex, Kasumpti- Shimla-171009, Phone: 0177-2620998/ 09418084973, Email: ravism17@yahoo.com

**Nagaland**

73. Shri. Pallab Changkakoti, Assistant professor, Dept., of Statistics, Kohima Science college, Jotsoma-797002, Nagaland, Phone: 0370-22922086 / 09435745480, Email: c.pallab@gmail.com
74. Shri. Inakhe Sumi, Nagaland Institute of Health Environment & Social Welfare, Opp. Commissioner's Office, Old Assembly Secretariat, Kohima, Nagaland-797001, Phone: 0370-2292086, 09744415175

## Experts Team

1. **Dr. D. K. Pandey**  
Scientist -E , RVPSP,  
Dept. of Science & Technology,  
Govt. Of India, Technology Bhawan,  
New Mehrauli Road ,  
New Delhi -110016,  
Ph: 011-26534738, Email: dkp@nic.in
2. **Dr.Pulin Behari Chakraborty,**  
Bidhan Chandra Krishi Viswavidyalaya ,  
A/81 Lake Gardens, Kolkata. 700045,  
Phone: 033-24220080 , Email:  
pbcomc0251@gmail.com
3. **Jayanta Kr Sarma,**  
SSEAEP, M.G. Road  
Nagaon-782001, Assam  
Email-jayanta.sarma@gmail.com  
Website-www.sseaep.org
4. **Dr.Lalit Sharma,**  
D-28/1:1, Sector 3, Sanpada,  
Navi Mumbai-400705,  
Ph: 9322264173,  
Email: drlalitsharma9@gmail.com
5. **Prof. E.Kunhikrishnan,**  
TC 1/2021, Jayamanju, Kamarapuram,  
Trivandrum-695011,  
Ph: 9447653786, Email: ekunhi@gmail.com
6. **Shri. U.N. Ravikumar,**  
No.37, 3<sup>rd</sup> Main, Bogadhi, 2<sup>nd</sup> Stage (South),  
Mysore-570026, Phone: 0821-2544014  
Email: unravi59@gmail.com
7. **Shri. Raghunath.T.P,**  
Pondicherry Science Forum, 10, IInd Street,  
P.R.Gardens, Reddiyarpalayam,  
Puducherry-605010,  
Mob.No.9443225288,  
Email: tprmenon@gmail.com
8. **Dr.M.R. Ramesh kumar,**  
Chief Scientist, National Institute of  
Oceanography,  
Dona Paula, Goa-403004  
Phone: 0832-2450304 Mob.No.9423056323.  
Email: kramesh@nio.org,  
rameshkumar.mr@gmail.com
9. **Dr. Sultan Ahmed Ismail,**  
Mananging Director, ERF, 98,Baaz Nagar,  
3/621, East Cost Road, Palavakkam,  
Chennai-600041.  
Ph: 044 24920786, Tel.: 09384898358,  
Email: sultanismail@gmail.com
10. **Prof.(Mrs.)V. Geethalakshmi,**  
Agro Climate Research Centre,  
Agricultural College and Research Institute,  
Tamil Nadu Agricultural University,  
Coimbatore-641003,  
Phone 0422-2430657  
Mob. No.9994433479. Email: geetha@tnau.ac.in
11. **Er.C.E. Karunakaran,**  
(Advisor, Centre for Ecology &  
Rural Development,Puducherry)  
No.26, Spur Tank road, Chetpet, Chennai-600031.  
Ph: 044-28361033, 9381041615,  
cekarun@gmail.com
12. **Shri. M.Basheer Ahmed,**  
Fineline, TTK Road, Chennai- 600014.,  
Mob: 9884322398, finelinebasheer@gmail.com

## Logistics & Support Team (Pondicherry Science Forum)

1. **Shri. R. Dakshinamurthy,**  
Vice President, PSF., Mob: 9443234522
2. **Shri. K. Vijayamurthy,**  
Core Group, PSF, Mob: 9994531488
3. **Shri. R. Ramesh,**  
Core Group, PSF, Mob: 9443385824
4. **Shri. R.Gunasekharan,**  
Treasurer, PSF, Mob: 9488510669
5. **Shri. S. Segar,**  
General Secretary, PSF. Mob: 9489771796
6. **Shri. S. Murugavel,**  
Core Group, PSF. Mob: 9486814358

## National Children's Science Congress, 2014 State Level Children's Science Congress REGISTRATION FORM - A

Fill this form in capital letters and submit to your District Co-ordinator

<b>1. State:</b>											
<b>2. District:</b>											
<b>3. Title of the Project :</b>											
<b>4. Language Used:</b>						<b>5. Area (Rural/Urban):</b>					
<b>6. Name of the Group Leader:</b>											
<b>7(a). Date of Birth:</b>				<b>b. Age as on 31/12/2014</b>			<b>8. Sex: (M/F)</b>				
<b>9. Name of Institution with Address:</b>											
PIN				Phone No(s).							
<b>10. Residential Address:</b>											
PIN				Phone No(s).							
<b>11. Particulars of the Team Member</b>											
i)a. Name:											
b. Date of Birth:				c. Age as on 31/12/2014			d. Sex: (M/F)				
Address											
ii)a. Name:											
b. Date of Birth:				c. Age as on 31/12/2014			d. Sex: (M/F)				
Address											
iii)a. Name:											
b. Date of Birth:				c. Age as on 31/12/2014			d. Sex: (M/F)				
Address											
iv)a. Name:											
b. Date of Birth:				c. Age as on 31/12/2014			d. Sex: (M/F)				
Address											
<b>12. Name of the Guide Teacher:</b>											
Address											
PIN				Phone No(s).							

Name and Signature of District Co-ordinator \_\_\_\_\_ Name and Signature of Head of the Institution \_\_\_\_\_

\* Age should be between 10-17 years as on 31st December of the current calendar year and Birth Certificate of each team member should be verified by the District Co-ordinator at the time of Registration.

N.B.: A copy of this Completed Registration Form must be enclosed with the Project Report.



Annexure VI

## [FORMAT OF THE ABSTRACT]

22<sup>nd</sup> National Children's Science Congress' 2014

STATE- .....

Sl. No./code.....

Language :.....

Title :STUDY ON MICROCLIMATE UNDER A BANYAN TREE

Narayanan, Gopinath, Sekhar, Ambiga, Sankar

**Government Middle School, Thavalakkuppam, Ariankuppam, Puducherry-605007**

E-mail: .....

## ABSTRACT

[ TEXT]

**Put your text here which will contain the Objectives, Objective wise Methodology & Workplan, Experiments carried out, Observation, Results and Analysis & Conclusion.**

**The Abstract should give clear idea as to what your project is, how it was carried out and also what has been the inferences and conclusion, follow up carried out etc.**

---

**Name & Address of Guide Teacher:**

**Note: 1. The write-up should be in New Times Roman in 12 point font**

**2. Group leader's name should be underlined, as shown above**

**ANNEXURE VII**

**POST MENTORING SCORE CARD FOR SELECTED PROJECTS  
(ONLY ORAL PRESENTATION)**

**22<sup>nd</sup> National Children's Science Congress**

State:.....

State Quota for NCSC National Event: .....Nos. selected for Oral Presentation : ..... Nos. selected for Poster Presentation : .....

Sl.No.	Name of the Participants (GL)	Title of the Project	Name of School/Institution/Organization	Language of Presentation	Marks scored		Assigned Grade after mentoring (A+/A/B+/B/C+/C)	Remarks
					District	State		

Reference for Award of Grades.

Marks	Grade
91-100	A +
81-90	A
71-80	B+
61-70	B
51-60	C+
41-50	C

Signature of SAC .....  
 Name of SAC .....  
 Phone: .....  
 Date: .....

Signature of Head State Coordinating Agency .....  
 State Coordinating Agency .....  
 with date and seal

Signature of State Coordinator .....  
 Name of State Coordinator: .....  
 Phone: .....